



**DEPARTMENT PUBLIC WORKS, ROADS AND
TRANSPORT:
ROADS AND TRANSPORT SERVICES**

TENDER NUMBER: PWRT(R&T) 05/2021

**REHABILITATION AND RESURFACING OF ROADS AS PER THE ANNUAL
ROADS PROJECT PLANS OVER A PERIOD OF 36 MONTHS**

**A Tender for Category 6 SB or 5 SB PE or higher CIDB Registered
Contractors**

Name of Tendering Entity	
Name of Tendering Entity Representative	
Physical Address of Tendering Entity	
Postal Address of Tendering Entity	
Contact Details of Tendering Entity	Tel. _____ Fax. _____ Cell _____
Tender Amount carried from Form of Offer (incl VAT)	R _____ (incl VAT)
CIDB Grading CRN No	
CSD MAAA	
TCS PIN No issue by SARS	

CONTENTS

NUMBER	HEADING	PAGE
	<u>The Tender</u>	
Part T1:	Tendering procedures	
T1.1	Tender Notice and Invitation to Tender	
	T1.1.6 Compulsory clarification meeting	
	T1.1.7 Closing date and time	
T1.2	Tender Data	
	T1.2.1 Standard Conditions of Tender	
	T1.2.2 Tender Data Information	
	F1.6 Procurement Procedures	
	F.2 Tenderer's Obligations	
	F3.11 Evaluation of tender Offers	
	Scoring Financial Offers	
	Functionality Requirements	
	F3.13. Acceptance of Tender Offer	
Part T2:	Returnable documents	
T2.1	List of Returnable Documents	
T2.2	Returnable Schedules	
	<u>The Contract</u>	
Part C1:	Agreement and Contract Data	
C1.1	Form of Offer	
C1.2	Form of Acceptance	
C1.3	Contract Data	
C1.4	Form of Guarantee	
Part C2:	Pricing data	
C2.1	Pricing Instructions	
C2.2	Schedule of Quantities	
Part C3:	Scope of Work	
C3.1	Description	
C3.2	Engineering	
C3.3	Procurement	
C3.4	Construction	
C3.5	Management	
C3.6.1	Project Specifications (Part 1)	
C3.6.2	Project Specifications (Part 2)	
	Variations and additions to the Standard Specifications for this	
	Contract and Particular Project Specifications	
C3.7	Generic Specification - Occupational Health and Safety	
Part C4:	Site information	
C4	Site Information	
Part C5:	Annexures	
C5.1	Annexure A : Occupational Health & Safety Act	
C5.2	Annexure B: Reduced Drawings for Tender Purposes	
C5.3	Annexure C: Typical Detail: Traffic Accommodation	

Note: The Tenderer must ensure that the documents he received are complete, as neither the Client nor the Engineer will accept any responsibility for any problem that may occur as a result of incomplete documentation.

Municipality 1		Municipality 2		Contractor	
----------------	--	----------------	--	------------	--

ADVERTISED IN: The Star
PUBLISHING DATE: 26 March 2021
TENDER NOTICE: PWR&T(R&T) 05/2021

MOGALE CITY LOCAL MUNICIPALITY

Tenders are hereby invited for the Department: Public Works, Roads and Transport:

**TENDERS ARE HEREBY INVITED FROM COMPETENT CIVIL ENGINEERING CONTRACTORS WITH A CIDB GRADING OF:
6 SB OR 5 SB OR HIGHER FOR REHABILITATION AND RESURFACING OF ROADS ON AS PER THE ANNUAL ROADS
PROJECT PLANS OVER A PERIOD OF 36 MONTHS**

Adjudication: 80/20

Tenders will be evaluated using functionality evaluation criteria of **51 points** of which the service provider is required to score the minimum of **28 points** in order to be considered for further evaluation. Tenders will also be evaluated at **80/20** preference point system which awards **80 points for Price** and **20 points for attaining the BBBEE** status level of contribution in accordance with the table below:

BBBEE Status level of contributor	Number of points(80/20 system)
1	20
2	18
3	14
4	12
5	8
6	6
7	4
8	2
Non –compliant contributor	0

Available Tender Document : tender document must be downloaded from mogalecity website at www.mogalecity.gov.za or www.etenders.gov.za

Technical Enquiries: Johan Britz

(011) 951 2141/082 448 5218

Johan.britz@mogalecity.gov.za

Tender Documents: Ofentse Matsose / Kefilwe Jobeta

(011) 951 2541 / 2014/2177

Ofentse.matsose@mogalecity.gov.za

Documents available: As **from 30 March 2021** during office hours, from the Reception Desk of Supply Chain Management Unity situated on the upper level of the West Wing; Mogale City Civic Centre, Corner of Commissioner and Market Street in Krugersdorp (011 951-2014/2016)

Closing date: **28 April 2021** Time: **11h00** Tender Box: **01**

Venue: Tender boxes are situated at the reception desk of the Supply Chain Management Unit, situated on the upper level of the West Wing of the Mogale City Civic Centre, Corner Commissioner and Market Streets in Krugersdorp.

Municipality 1		Municipality 2		Contractor	
----------------	--	----------------	--	------------	--

Tender conditions:

- ❖ Bidders to tender for all four Sections, with rates to be provided for all Sections as it is intended to appoint more than one Service providers for all Sections.
- ❖ All Service providers / contractors must submit valid, certified copies of their BEE certificates from an accredited BEE verification agency with their tender submission. Failure to submit a BEE certificate will lead to forfeiture (loss) of the preference points.
- ❖ In the instance of Exempted Micro Enterprises (EME) (turnover less than R5m) a letter from a professional, registered accountant/ auditor in order to qualify for preference points.
- ❖ Requirements for sealing, addressing, delivery, opening and assessment of tenders are stated in the tender document;
- ❖ A valid original Tax Clearance Certificate/ TCS PIN no (or in the case of a Joint Venture, of all the partners in the Joint Venture) must be submitted with the tender document;
- ❖ Tenders by joint ventures are to be accompanied by the Document Formation of the joint venture, duly registered and authenticated by a Notary Public or other official deputized to witness sworn statements. This document must define precisely the conditions under which the joint venture will function, the period for which it will function, the persons authorized to represent and obligate it, the address for correspondence, the participation of several firms forming the joint venture and any information necessary to permit a full appraisal of its functioning, including a clause to the effect that the members of the joint venture are jointly and severally bound.
- ❖ A trust, consortium or joint venture will qualify for points for the BBBEE status level as a legal entity, provided that the entity submits their consolidated BBBEE status level certificate.
- ❖ Bidders will not be disqualified from the bidding process of the bidder does not submit a certificate substantiating the BBBEE level of contribution or is a non-compliant contributor. Such a bidder will score 0 out of a maximum of 10 points for BBBEE.
- ❖ No late tender will be accepted.
- ❖ Telefax or e-mail tenders are not acceptable.
- ❖ Tenders may only be submitted on the bid documents as provided by Mogale City. The use of tipp-ex is not allowed on the bid documents. Bids completed in pencil will be regarded as invalid bids. No page(s) may be removed from the original tender document
- ❖ The lowest or any tender will not necessarily be accepted, and Mogale City reserves the right to accept a tender in whole or in part.
- ❖ If the appointed company/service provider is not based in the area of jurisdiction of Mogale City, a Corporate Social Responsibility Contribution of one (1) percent will be levied on all payments made to than company/ service provider.
- ❖ **All tender prices must be inclusive of VAT**

MR MP Raedani
MUNICIPAL MANAGER

PART A

Municipality 1		Municipality 2		Contractor	
----------------	--	----------------	--	------------	--

INVITATION TO BID

YOU ARE HEREBY INVITED TO BID FOR REQUIREMENTS OF MOGALE CITY LOCAL MUNICIPALITY

BID NUMBER:	PWRT (R&T)05/20201	CLOSING DATE:	28 APRIL 2021	CLOSING TIME:	11h00
--------------------	------------------------------	----------------------	---------------	----------------------	-------

DESCRIPTION

THE SUCCESSFUL BIDDER WILL BE REQUIRED TO FILL IN AND SIGN A WRITTEN CONTRACT FORM (MBD7).

BID RESPONSE DOCUMENTS MAY BE DEPOSITED IN THE BID BOX

SITUATED AT (STREET ADDRESS

SUPPLIER INFORMATION

NAME OF BIDDER			
POSTAL ADDRESS			
STREET ADDRESS			
TELEPHONE NUMBER	CODE		NUMBER
CELLPHONE NUMBER			
FACSIMILE NUMBER	CODE		NUMBER
E-MAIL ADDRESS			
VAT REGISTRATION NUMBER			

TAX COMPLIANCE STATUS	TCS PIN:		OR	CSD No:	
B-BBEE STATUS LEVEL VERIFICATION CERTIFICATE [TICK APPLICABLE BOX]	<input type="checkbox"/> Yes <input type="checkbox"/> No		B-BBEE STATUS LEVEL SWORN AFFIDAVIT	<input type="checkbox"/> Yes <input type="checkbox"/> No	

[A B-BBEE STATUS LEVEL VERIFICATION CERTIFICATE/ SWORN AFFIDAVIT (FOR EMES & QSEs) MUST BE SUBMITTED IN ORDER TO QUALIFY FOR PREFERENCE POINTS FOR B-BBEE]

ARE YOU THE ACCREDITED REPRESENTATIVE IN SOUTH AFRICA FOR THE GOODS /SERVICES /WORKS OFFERED?	<input type="checkbox"/> Yes <input type="checkbox"/> No [IF YES ENCLOSE PROOF]	ARE YOU A FOREIGN BASED SUPPLIER FOR THE GOODS /SERVICES /WORKS OFFERED?	<input type="checkbox"/> Yes <input type="checkbox"/> No [IF YES, ANSWER PART B:3]
TOTAL NUMBER OF ITEMS OFFERED		TOTAL BID PRICE	R
SIGNATURE OF BIDDER	DATE	
CAPACITY UNDER WHICH THIS BID IS SIGNED			

Municipality 1		Municipality 2		Contractor	
----------------	--	----------------	--	------------	--

BIDDING PROCEDURE ENQUIRIES MAY BE DIRECTED TO:		TECHNICAL INFORMATION MAY BE DIRECTED TO:	
DEPARTMENT	SUPPLY CHAIN MANAGEMENT	CONTACT PERSON	PWRT
CONTACT PERSON	Ofentse Matsose	TELEPHONE NUMBER	Johan Britz
TELEPHONE NUMBER	011951-2141/2177	TELEPHONE NUMBER	011 951-2141
FACSIMILE NUMBER		E-MAIL ADDRESS	
E-MAIL ADDRESS	Ofentse.matsose@mogalecty.gov.za	E-MAIL ADDRESS	Johan.britz@mogalecity.gov.za

PART B
TERMS AND CONDITIONS FOR BIDDING

1. BID SUBMISSION:
<p>1.1. BIDS MUST BE DELIVERED BY THE STIPULATED TIME TO THE CORRECT ADDRESS. LATE BIDS WILL NOT BE ACCEPTED FOR CONSIDERATION.</p> <p>1.2. ALL BIDS MUST BE SUBMITTED ON THE OFFICIAL FORMS PROVIDED–(NOT TO BE RE-TYPED) OR ONLINE</p> <p>1.3. THIS BID IS SUBJECT TO THE PREFERENTIAL PROCUREMENT POLICY FRAMEWORK ACT AND THE PREFERENTIAL PROCUREMENT REGULATIONS, 2017, THE GENERAL CONDITIONS OF CONTRACT (GCC) AND, IF APPLICABLE, ANY OTHER SPECIAL CONDITIONS OF CONTRACT.</p>
2. TAX COMPLIANCE REQUIREMENTS
<p>2.1 BIDDERS MUST ENSURE COMPLIANCE WITH THEIR TAX OBLIGATIONS.</p> <p>2.2 BIDDERS ARE REQUIRED TO SUBMIT THEIR UNIQUE PERSONAL IDENTIFICATION NUMBER (PIN) ISSUED BY SARS TO ENABLE THE ORGAN OF STATE TO VIEW THE TAXPAYER'S PROFILE AND TAX STATUS.</p> <p>2.3 APPLICATION FOR THE TAX COMPLIANCE STATUS (TCS) CERTIFICATE OR PIN MAY ALSO BE MADE VIA E-FILING. IN ORDER TO USE THIS PROVISION, TAXPAYERS WILL NEED TO REGISTER WITH SARS AS E-FILERS THROUGH THE WEBSITE WWW.SARS.GOV.ZA.</p> <p>2.4 FOREIGN SUPPLIERS MUST COMPLETE THE PRE-AWARD QUESTIONNAIRE IN PART B:3.</p> <p>2.5 BIDDERS MAY ALSO SUBMIT A PRINTED TCS CERTIFICATE TOGETHER WITH THE BID.</p> <p>2.6 IN BIDS WHERE CONSORTIA / JOINT VENTURES / SUB-CONTRACTORS ARE INVOLVED, EACH PARTY MUST SUBMIT A SEPARATE TCS CERTIFICATE / PIN / CSD NUMBER.</p> <p>2.7 WHERE NO TCS IS AVAILABLE BUT THE BIDDER IS REGISTERED ON THE CENTRAL SUPPLIER DATABASE (CSD), A CSD NUMBER MUST BE PROVIDED.</p>
3. QUESTIONNAIRE TO BIDDING FOREIGN SUPPLIERS
<p>3.1. IS THE ENTITY A RESIDENT OF THE REPUBLIC OF SOUTH AFRICA (RSA)? <input type="checkbox"/> YES <input type="checkbox"/> NO</p> <p>3.2. DOES THE ENTITY HAVE A BRANCH IN THE RSA? <input type="checkbox"/> YES <input type="checkbox"/> NO</p> <p>3.3. DOES THE ENTITY HAVE A PERMANENT ESTABLISHMENT IN THE RSA? <input type="checkbox"/> YES <input type="checkbox"/> NO</p> <p>3.4. DOES THE ENTITY HAVE ANY SOURCE OF INCOME IN THE RSA? <input type="checkbox"/> YES <input type="checkbox"/> NO</p> <p>3.5. IS THE ENTITY LIABLE IN THE RSA FOR ANY FORM OF TAXATION? <input type="checkbox"/> YES <input type="checkbox"/> NO</p>

Municipality 1		Municipality 2		Contractor	
----------------	--	----------------	--	------------	--

IF THE ANSWER IS “NO” TO ALL OF THE ABOVE, THEN IT IS NOT A REQUIREMENT TO REGISTER FOR A TAX COMPLIANCE STATUS SYSTEM PIN CODE FROM THE SOUTH AFRICAN REVENUE SERVICE (SARS) AND IF NOT REGISTER AS PER 2.3 ABOVE.

NB: FAILURE TO PROVIDE ANY OF THE ABOVE PARTICULARS MAY RENDER THE BID INVALID. NO BIDS WILL BE CONSIDERED FROM PERSONS IN THE SERVICE OF THE STATE.

SIGNATURE OF BIDDER:

CAPACITY UNDER WHICH THIS BID IS SIGNED:

DATE:

Municipality 1		Municipality 2		Contractor	
----------------	--	----------------	--	------------	--

PART T1 : TENDERING PROCEDURES

Municipality 1		Municipality 2		Contractor	
----------------	--	----------------	--	------------	--

THE TENDER

Part T1 TENDERING PROCEDURES

T1.1 Tender Notice and Invitation to Tender

T1.1.1 **Tenders are hereby invited from competent Civil Engineering Contractors with the CIDB grading of 6 SB or 5 SB PE or higher FOR CONSTRUCTION OF SURFACE SEALS, ASPHALT BASE AND SURFACINGS ON AN AS PER THE ANNUAL ROADS PROJECT PLANS OVER A PERIOD OF A PERIOD OF THIRTY SIX (36) MONTHS**
Joint ventures are eligible to submit tenders provided that:

1. Every member of the joint venture is registered with the CIDB;
2. The lead partner has a contractor grading designation as follows:
Section 1 to 4: 6SB or 5 SB PE or higher class of construction work
3. The combined contractor grading designation calculated in accordance with the Construction industry Deve4lopment Regulations is equal to or higher than a contractor grading designation determined in accordance with a value determined in accordance with Regulation 25 (1 B) or 25(7A) of the Construction Industry Development Regulations.
4. Partners in a Joint Venture are only allowed to form a Joint Venture with a single set of partners.

T1.1.2 Tenders will be evaluated using the 90/10 preference point system which awards points on the basis of 90 for price and 10 points for BBEE status level of contribution

T1.1.3 Preferences points are awarded on the basis of the B-BBEE Status Level of the tenderer.

T1.1.4 The physical address for collection of tender documents is:

Mogale City Local Municipality
Reception Desk of Supply Chain Management Unity
Upper level of the West Wing; Mogale City Civic Centre
Cnr. Commissioner & Market Street, Krugersdorp

Documents can be downloaded from the Mogale City website (www.mogalecity.gov.za) or from www.etenders.gov.za

T1.1.5 Queries relating to the issue of these documents may be addressed to:

Ofentse Matsose Tel: (011) 951 2541 or 071 884 6958

E-mail: ofentse.matsose@mogalecity.gov.za

Technical queries relating to the works may be addressed to:

ROADS AND TRANSPORT SERVICES Rep: Mr. Johan Britz Tel 011 951 2141

E-mail: johan.britz@mogalecity.gov.za

T1.1.6 No clarification meeting with representatives of the Employer & Engineer will take place.

T1.1.7 The closing time and date for receipt of tenders as per Tender Invitation

T1.1.8 Telegraphic, telephonic, telex, facsimile and late tenders will not be accepted. Requirements for sealing, addressing, delivery, opening and assessment of tenders are stated in the Tender Data.

T1.1.9 Tenders will be opened in public by Supply Chain at Tender Box 2

T1.2 TENDER DATA

T1.2.1 Standard Conditions of Tender

The conditions of tender are the Standard Conditions of Tender as contained in Annex F of the CIDB Standard for Uniformity in Construction Procurement. (The tenderer to obtain a copy of the Annex F from the CIDB website www.cidb.org.za).

The Standard Conditions of Tender make several references to the Tender Data for details that apply specifically to this tender. The Tender Data shall have precedence in the interpretation of any ambiguity or inconsistency between it and the Standard Conditions of Tender. Each item of data given below is cross-referenced to the clause in the Standard Conditions of Tender to which it mainly applies

T1.2 Tender Data Information

The following information is based on the Standard Conditions of Tender and refers to the relevant clauses of the Standard Conditions of Tender. The following Clauses are highlighted. It is the responsibility of the Tenderer to obtain the full CIDB Standard Conditions of Tender from their website. www.cidb.co.za

Clause

F1.1 The Employer is: **Mogale City Local Municipality**

F.1.2 The documents listed below will form part of this contract. The tender documents issued by the employer comprise Volume 3. The employer does not supply Volumes 1 and 2. Tenderers are to acquire their own copies of these documents.

Volume 1 The **General Conditions of Contract for Construction Works (2015)** published by the South African Institution of Civil Engineering, is applicable to this contract. Copies of these conditions of contract may be obtained from the South African Institution of Civil Engineering (tell: 011-805-5947).

Volume 2 **Standardised specifications for Civil Engineering Construction SABS 1200** - not bound in this document and obtainable from: The South African Bureau of Standards, Private Bag X191, Pretoria, 2001.

COLTO: Standard Specifications for Road and Bridge Works – , published by COLTO (Committee of Land Transport Officials) - not bound in this document and obtainable from the South African National Roads Agency Limited, PO Box 415, Pretoria, 0001.

email Address info@nra.co.za ; <http://www.nra.co.za/>

Municipality 1		Municipality 2		Contractor	
----------------	--	----------------	--	------------	--

Volume 3 The tender documents issued by the Employer comprise:

Tendering Procedures

T1.1 Tender notice and invitation to tender
Clarification Meeting / Site Inspection Certificate

T1.2 Tender Data

T2.1 List of returnable documents

T2.2 Returnable schedules

Part 1 - Agreements and Contract Data

C1.1 Form of offer

C1.2 Form of acceptance

C1.3 Contract Data

C1.4 Form of Guarantee

Part 2 - Pricing data

C2.1 Pricing instructions

C2.2 Schedule of Quantities

Part 3 - Scope of work

C3.1 Description

C3.2 Engineering

C3.3 Procurement

C3.4 Construction

C3.5 Management

C3.6.1 Project Specifications – Part 1 General

C3.6.2 Project Specifications – Part 2 Variations and additions and
Particular Specifications

C3.7 Generic Specifications

Part 4 – Site Information

C4.1 Site information

Part 5 - Annexures

Annexure A : Occupational Health & Safety Act

Annexure B : Reduced drawings for tender purposes

Annexure C: Typical Detail of Traffic Accomodation

Municipality 1		Municipality 2		Contractor	
----------------	--	----------------	--	------------	--

F1.4 Communication and Employer's Agent

Each communication between the Employer and a tenderer shall be to or from the Employer's agent only, and in a form that can be read, copied and recorded. Writing shall be in the English language. The Employer shall not take any responsibility for non-receipt of communications from or by a tenderer.

The Employer's Agent is:

Name: Johan Britz

Address: 3rd Floor President Building, C/o President & Monument Streets, Krugersdorp, 1740

Tel No: **011 – 951 2141**

Fax No: **011 – 660 9672**

E-mail: **johan.britz@mogalecity.gov.za**

The Engineer per GCC 2015: Andre Botes (Manager: Roads and Transport)

F1.5 The Employer's right to accept or reject any tender offer

F.1.5.1 The Employer may accept or reject any variation, deviation, tender offer, or alternative tender offer, and may cancel the tender process and reject all tender offers at any time before the formation of a contract. The Employer shall not accept or incur any liability to a tenderer for such cancellation and rejection, but will give reasons for such action upon written request to do so.

F.1.5.2 the Employer may accept the tender in full or accept a portion (Section) thereof only

F1.6 Procurement Procedures

F1.6.1 Data Pertaining to Targeted Procurement

This tender will be adjudicated and awarded in terms of the Mogale City Local Municipality Procurement Policy. The complete document can be requested from Mogale City Local Municipality

F1.6.2 Corporate Social Responsibility

A contribution of 1% of the value of the contract must be made by contractors not based in Mogale City Local Municipality Jurisdiction as Social Responsibility Contribution for the development of the Community of Mogale. The 1% contribution will be deducted from all certified payments to the contractor and will be deducted from the amount payable before payment is issued.

F1.6.3 Preferential Procurement Regulations – B-BBEE Compliance Level (from 07 December 2010)

The new Preferential Procurement Regulations have arrived as a result of the recently promulgated Preferential Procurement Policy Framework Act (PPPFA). These new regulations are the final part of implementing BBBEE as contemplated in the Broad Based Black Economic Empowerment Act.

Clients/Implementing Agencies calling for tenders are now compelled to consider compliance to the Codes of Good Practice when evaluating tenders and that all tenders be accompanied by a valid B-BBEE certificate, issued by an accredited verification agency. The PPPFA and new rules are effective as of April 2017.

Municipality 1		Municipality 2		Contractor	
----------------	--	----------------	--	------------	--

B-BBEE points are awarded on the basis of the B-BBEE Status Level of the tenderer. In the event that two or more tenders have scored equal points, the successful tender must be the one scoring the highest number of preference points for B-BBEE.

Evidence of B-BBEE status

- A tenderer must submit their original (or certified copy) valid B-BBEE status level verification certificate substantiating their B-BBEE rating.
- Exempt Micro Enterprises (EME's) must submit a certificate issued by a registered auditor, accounting officer, or an accredited verification agency.
- The validity of B-BBEE certificates will be determined by its compliance with the requirements of instructions and guidelines issued by the National Treasury and any notices published by the Department of Trade and Industry in the Government Gazette.

JV's and sub-contracting:

- Incorporated JV's must submit the B-BBEE status of the entity. Unincorporated JV's must submit a consolidated B-BBEE scorecard as if they were a group structure for every separate tender.
No sub-contracting is required
- **The pre-qualification criteria applicable to this tender as per clause 4.1 (c)(i) of the Government Gazette no 40553 of 20 April 2017, will apply:**

C1.6.5 Data Pertaining to CIDB Registration

Basis for CIDB Rating Requirement – CIDB Table 8

A contractor registered in a specific contractor's grading designation indicated in column 1 of Table 8, is considered to be capable of undertaking a contract in the range of values indicated in columns 3 and 4 in the class of construction works to which the category of registration relates to:

Table 8 amended by Government Notice No. 8986 of 14 Nov 2008 published Government Gazette no. 31603 of 14 Nov 2008

Contractor Grading Designation	Tender Value Range Designation	Less Than or Equal to (R)
1 (Class of Construction Works)	1	R 200 000
2 (Class of Construction Works)	2	R 650 000
3 (Class of Construction Works)	3	R 2 000 000
4 (Class of Construction Works)	4	R 4 000 000
5 (Class of Construction Works)	5	R 6 500 000
6 (Class of Construction Works)	6	R13 000 000
7 (Class of Construction Works)	7	R40 000 000
8 (Class of Construction Works)	8	R130 000 000
9 (Class of Construction Works)	9	"No limit"

Information regarding the CIDB can be obtained from their website: www.cidb.org.za

Potentially emerging enterprises

Subregulation (7A) Government Notice 842 of 29138 published in Government Gazette No. 29138 of 18 August 2006 states that:

(8) Within the framework of a targeted development programme promoted by a client or employer, that client or employer may accept for evaluation tender offers or expressions of interest by a contractor who is

Municipality 1		Municipality 2		Contractor	
----------------	--	----------------	--	------------	--

registered as a potentially emerging enterprise in terms of these Regulation, one level higher than the contractors registered grading designation if that client or employer-

- (a) is satisfied that such a contractor has the potential to develop and qualify to be registered in a higher grade; and
- (b) ensures that financial, management or other support is provided to that contractor to enable the contractor to successfully execute that contract

F.2 Tenderer’s Obligations

F2.1 Eligibility of the Tender.

F2.1.1 Only those tenderers who have a valid and updated registration with the Construction Industry Development Board (CIDB) are eligible to submit tenders. Proof of Registration to be attached.

F2.1.2 Only those tenderers who have in their employ management and supervisory staff satisfying the requirements of the Scope of Work.

F2.1.3 Only tenderers who are registered with the CIDB, are eligible to submit tenders:

- a) contractors who have a contractor grading designation equal to or higher than a contractor grading designation determined in accordance with the value in a class of construction work as per CIDB Table G1; and

Description	Grading Required
REHABILITATION AND RESURFACING OF ROADS AS PER THE ANNUAL ROADS PROJECT PLANS OVER A PERIOD OF 36 MONTHS	

and who satisfy the following criteria, that the employer:

- (a) is satisfied that such a contractor has the potential to develop and qualify to be registered in a higher grade; and
- (b) ensures that financial, management or other support is provided to the contractor by a main contractor/mentor to enable the contractor to successfully execute the contract

F2.1.4 Only tenders from competent & experienced Tenderers will be considered. The Tenderer must indicate his relevant experience (similar to the Scope of Works as tendered for) in the schedule (Schedule G) provided under Technical Evaluation Criteria

Appointment of a contractor for this Tender is subject to compliance with the Tender requirements and availability of funds for the implementation.

If no information is provided, the tenderer will be considered as inexperienced in the work tendered for and may therefore be disqualified.

F2.1.5 Only tenderers that are capable to provide a construction guarantee to 10% of the contract value (excl. VAT & Contingencies) for the full duration of the construction period from a Registered Financial Institution or Accredited Financial Provider registered at the Financial Services Board. Letter of Intent and previous Guarantee history should be provided.

Municipality 1		Municipality 2		Contractor	
----------------	--	----------------	--	------------	--

F2.1.6 Joint ventures are eligible to submit tenders provided that:

- a) every member of the joint venture is registered with the CIDB;
- b) the lead partner has a contractor grading designation of :
5 SB PE or higher class of construction work in the Civil Engineering work classification for Section A &C (Civil & Building Works) and he combined contractor grading designation calculated in accordance with the Construction Industry Development Regulations is equal to or higher than a contractor grading designation determined in accordance with the sum tendered for 5 SB PE of Civil Engineering work. (Refer to the schedule below)

Table of Joint Venture Combinations

Designation	Deemed to satisfy joint venture arrangements
3	Three contractors registered in contractor grading designation 2
4	Three contractors registered in contractor grading designation 3
5	Two contractors registered in contractor grading designation 4 One contractor registered in contractor grading designation 4 and two registered in contractor grading designation 3
6	Two contractors registered in contract grading designation 5 One contractor registered in contract grading designation 5 and two registered in contract grading designation 4
7	Two contractors registered in contractor grading designation 6 One contractor registered in contractor grading designation 6 and two registered in contractor grading designation 5
8	Three contractors registered in contractor grading designation 7
9	Three contractor registered in contractor designation 8

F2.2 Cost of Tendering

The Employer is not responsible for any costs or losses incurred by any Tenderer during the preparation of his Tender or the visit to site for the official site inspection.

F.2.3 Check documents

Check the tender documents on receipt for completeness and notify the Employer of any discrepancy or omission.

F.2.4 Confidentiality and copyright of documents

Treat as confidential all matters arising in connection with the tender. Use and copy the documents issued by the Employer only for the purpose of preparing and submitting a tender offer in response to the invitation.

Any receiver of tender documents whether a Tender is submitted or not must consider the contents of the documents as private and confidential.

Municipality 1		Municipality 2		Contractor	
----------------	--	----------------	--	------------	--

Information supplied by Tenderers relating to the examination, clarification, evaluation and adjudication of tenders and recommendations for the award of the contract will not be disclosed to Tenderers or any other persons not officially concerned with such processes.

If so instructed by the Procurement Department, return all retained tender documents within 28 days after the expiry of the validity period stated in the Tender Document.

F.2.5 Reference documents

Obtain, as necessary for submitting a tender offer, copies of the latest versions of standards, specifications, Conditions of Contract and other publications, which are not attached but which are incorporated into the tender documents by reference.

F.2.6 Acknowledge addenda

Acknowledge receipt of addenda to the tender documents, which the Employer may issue, and if necessary apply for an extension to the closing time stated in the Tender Data, in order to take the addenda into account.

F2.7 Site Visit and Clarification Meeting:

Date: As per Tender Invitation

Venue: As per Tender Invitation

Time: As per Tender Invitation

A person who is suitably qualified and experienced to comprehend the implications of the work involved, must represent that tenderer at the briefing and the site inspection. If the tenderer or its representative does not attend the site meeting, the tender will be disqualified.

Tenderers must sign the attendance list in the name of the tendering entity. Tenders and Addenda will only be issued to those tendering entities appearing on the attendance list.

F2.9 Insurance

The contractor will be required to provide the following insurances (securities) and the tenderer is advised to seek qualified advice regarding insurance.

F.2.9.1 Contract Work Insurance (Also Refer to Clause 7 GCC 2015)

A Fixed Construction Guarantee to the employer equal in value to 10% of the contract value excluding VAT & Contingencies and escalation if applicable by an institution approved by the employer. The amount so deposited, or the Surety ship so furnished, shall be held until the completion of the Contract, as security that the Contract shall be implemented and carried out to the fullest extent of its terms by the Contractor.

The fixed construction guarantee shall come into force on the date of issue and shall lapse on the date of Completion Certificate being issued.

Municipality 1		Municipality 2		Contractor	
----------------	--	----------------	--	------------	--

The employer or his representatives shall return the original fixed construction guarantee policy contract to the contractor within fourteen (14) days from the date of Completion Certificate being issued.

The Contractor is expected to provide a valid and original Construction Guarantee at time of site handover. Should the contractor fail to furnish the required construction guarantee the employer, in his sole discretion may cancel the agreement with the appointed contractor.

The Tenderer is to state clearly in the Tender form which of the forms of Surety specified, he proposes to submit in the event of his being called upon to take up the Contract, either:

- [a] Bank Guarantee Or
- [b] Surety Bond by an approved Insurance Company

F.2.9.2 Public Liability Insurance

This insurance provides indemnity against legal liability in the event of accidental death of or injury to a third party person and/or loss of or damage to third party property directly arising from the performance of the contract and occurring during the period of insurance with an indemnity limit of R 10 million of all claims arising from any one event or series of events resulting from or attributable to any one source or original source.

F.2.9.3 Insurance to be effected by the contractor

The contractor or subcontractor must supply the following insurance, where applicable:

- a) Insurance for construction machinery and plant (including tools, offices and other temporary structures and content) and other items – other than those intended for incorporation into the works – brought onto site for an amount adequate to replace same.
- b) Insurance under the provision of the Compensation for Occupational Injuries and Diseases Act, 1993 (Act No. 130 of 1993).
- c) Motor vehicle liability insurance with (at least) indemnification for “balance of third party” risk, including passenger liability.
- d) If the contract entails manufacture and/or assembly of the works or parts thereof on a site other than the contract site, the contractor must satisfy the employer that all materials and equipment intended for incorporation into the works are adequately insured during the manufacture or assembly, such interest should be recorded by way of endorsement on the policies concerned.
- e) A Coupon Policy for Special All Risk Insurance issued by the South African Special Risk Insurance Association to cover all materials (bought by the contractor or by cession) and works already constructed against damage; looting; fire due to civil unrest (SASRIA)

F2.10 Pricing the tender offer

F2.10.1 The tenderer must allow in the tendered rates for all labour, materials, equipment, temporarily works, arrangements, etc, for the satisfactory completion of the Works according to the Tender documents. No additional payments will be considered.

Municipality 1		Municipality 2		Contractor	
----------------	--	----------------	--	------------	--

Should a tenderer wish to deviate from the specifications or propose different construction materials or methods, he may do so, provided that full details are submitted with the tender. Notice of any deviations or alterations must be given in SCHEDULE A.

F2.10.3 A provisional amount for VAT must be allowed for in the Schedule of Quantities. The amount allowed is fourteen percent of the Tender amount including contingencies. All payment claims must be accompanied by a Tax Certificate in accordance with the requirements of the Income Tax Law

F2.12. Alternative Offer.

1. The council will consider an alternative tender submitted by the tender for a proposal or design other than that incorporated in the Tender Documents.
2. No alternative tender will be considered unless this tender is also submitted free of qualifications and strictly in accordance with the instructions given in the tender document, the tenderer is obliged also to tender for the council's designs.
3. The alternative tender shall include the following information in sufficient details and to the same standards as the tender documents to enable the alternative tender to be considered from the technical, financial and other aspects in relating to the council's design:

a) Technical Details

Full details of design parameters utilised for alternative tender, attention being given to deviations from and interpretations of the data in the tender documents.

b) Drawing and Specifications

- i. Detailed specifications for those of the alternative tender not covered by the council's specifications.
- ii. Drawings fully describing the alternative tender

c) Risk

- i. Statement of the effect that the alternative tender has on the sharing of risk between the council and the contractor. Any increased risk to the council shall be described.
- ii. Risk unacceptable to the council will render the tender liable to be rejected by the council.

d) Schedule of Quantities

A detailed price schedule of quantities shall be submitted and shall cover the following aspects:

- i. The cost implication of any change in risk
- ii. The cost implication of qualifications to the tender (qualifications not priced will render the alternative tender liable to be rejected by the council)
- iii. Any items not priced in the alternative tender shall be deemed to be included in the rates and prices tendered

e) Construction Programme

A detailed programme stating advantage, if any, over the programme utilising the council's design for the works

- 4 Should the alternative tender include any building work to be carried out in compliance with the National Building Regulations, the tender shall certify that the alternative proposals will be in accordance with the

Municipality 1		Municipality 2		Contractor	
----------------	--	----------------	--	------------	--

National Building Regulations. Payment will not be made by the council in respect of such building work prior to the approval by the council of the alternative building plans.

5. The alternative tender will be regarded as incomplete and is liable to be rejected by the council should
 - a) The council's design be not priced by the tender where so required in terms of sub-paragraph (2) above
 - b) The data in respect of the alternative tender in terms of sub-paragraphs (3) and (4) above be not submitted.
6. Acceptance of an alternative tender offer will mean acceptance in principle of the offer. It will be an obligation of the contract for the tenderer, in the event that the alternative is accepted, to accept full responsibility and liability that the alternative offer complies in all respects with the Employer's standards and requirements.
7. The modified Pricing Data must include an amount equal to 5% of the amount tendered for the alternative offer to cover the Employer's costs of confirming the acceptability of the detailed design before it is constructed.

F2.13 Submitting a Tender Offer

Submit one tender offer only, either as a single entity or as a member of a Joint Venture to provide the whole of the works, services identified in the contract data and described in the Scope of Works. Members/Partners in a JV may only submit ONE tender with one set of partners. If a member/partner in a JV also commit to a partnership with another company BOTH tenders will be disqualified as unfair competition.

Tenderers must submit an offer for all the items on offer. An original tender document with all pages intact including drawings with no copies to be submitted.

Alternative tender offers to be submitted in original format i.e Schedule of Quantities & Drawings

F2.13.5 Tender Envelope Information

Employers Address: Mogale City Local Municipality
P.O. Box 94, KRUGERSDORP, 1740
Mogale Civic Centre; Commissioner Street, KRUGERSDORP

Location of Tender Box: Mogale City Local Municipality
Tender Box located at the Reception Desk of Supply Chain Management,
Upper Level, West Wing, Mogale Civic Centre

Identification Details:

Municipality 1		Municipality 2		Contractor	
----------------	--	----------------	--	------------	--

Description of Project: **CONSTRUCTION OF SURFACE SEALS, ASPHALT BASE AND SURFACINGS
AS PER THE ANNUAL ROADS PROJECT PLANS OVER A PERIOD OF
THIRTY SIX (36) MONTHS**

Telephonic, telegraphic, telex, facsimile or e-mailed tender offers will not be accepted. Late tenders will be disqualified.

F2.13.6 Two Envelope Procedure

A two envelope procedure will not be followed.

F.2.13.9 Facsimile / Fax or E-mailed Tenders

Fax; facsimile or e-mail tenders will not be accepted.

F2.14 Tender all complete

Accept that tender offers, which do not provide all the data or information as requested completely or in the form required, may be regarded by the employer as non-responsive.

The following criteria will be used to establish completeness for responsive tenders

Criteria	Complete Yes	Incomplete No
Tenderer has attended the compulsory site inspection	N/a	N/a
Tender document returned in original form including drawings issued for tender purposes		
Tenderer has signed and completed the Form of Tender		
Tenderer has completed and signed all Returnable documents		
Schedule of Quantities has been completed in full in black ink, all items completed as instructed and Summary Page has been signed		
Tenderer has supplied ORIGINAL VAT Clearance Certificate		
Tenderer has supplied a valid B-BBEE certificate, issued by an accredited verification agency for all tendering entities (JV Partners) where applicable		
Contractor has supplied fully paid-up Municipal Account (no more than 3 months old)		
Contractor has supplied Letter of Good Standing for Workmen Compensation		
Contractor has completed Bank Details or provided a cancelled cheque		

F2.15 Closing Date & Time

Closing Date As per Tender Invitation

Closing Time: As per Tender Invitation

Municipality 1		Municipality 2		Contractor	
----------------	--	----------------	--	------------	--

F2.16 Tender Offer Validity

90 Calendar Days from Closing Date.

- (a) The tenderer may withdraw or alter his tender prior to the closing date of the tender.
- b) No tenderer may withdraw his tender for a period of **90 days** after the closing date of tenders.
- c) If a tenderer should wish to amend or withdraw his tender after the closing date:
 - 1. He gives notice that he is not in a position to perform in accordance with his tender; or
 - 2. Fails to sign the Tender or to submit the required Bond; or
 - 3. Fails to perform

he will be liable for any additional expenses the employer may incur in calling for new tenders or the difference between his tender and a less advantageous tender, except if the employer considers the circumstances justified and relieves the tenderer of his obligations.

F2.17 Clarification of tender offer after submission

The original Tender as amended or corrected in writing (if required) will be accepted as the Tenderer's offer. The employer may request additional information from any Tenderer with regard to his Tender. No Tenderer will be allowed to alter the Tender amount stated in his tender. Explanations which do not influence the Tender amount may be accepted by the Employer.

F2.23 Certificates to be submitted

The following certificates need to be included in the Tender:

- a) A valid Original SARS and or VAT Clearance Certificate for the tenderer or Joint Venture Tenderer for each of the JV partners issued by the South African Revenue Services;
- b) A valid B-BBEE certificate, issued by an accredited verification agency.
- c) The tenderer's CIDB Registration Certificate or the JV's CIDB Registration Certificates for each JV partner with an indication of the senior partner.
- d) The tenderers fully paid-up Municipal Account in the name of the Business not older than 3 months. Lease agreement to be provided where office is leased.
- e) Workman's Compensation Commissioner - Letter of Good Standing
- f) Completion Certificates of a minimum of 5 successful projects completed.

F.3 **Employers Undertaking**

F3.4 Opening of Tender Submissions

Tender submissions will be opened in public by Supply Chain Management.

F3.8 Test for responsiveness

The employer or his representative will determine after opening and before detail evaluation whether each tender offer received:

- 1. Complies with the requirements of these Conditions of Tender in terms of Eligibility
- 2. Has been properly and fully completed and signed,
- 3. And is responsive to the other requirements of the tender document

Municipality 1		Municipality 2		Contractor	
----------------	--	----------------	--	------------	--

A responsive tender is one that conforms to all the terms, conditions and specifications of the tender documents without material deviations or qualifications. A material deviation or qualification is one which, in the opinion of the employer or his representative, would:

- Detrimently affect the scope, quality or performance of the works, services or supply identified in the Scope of Work
- Significantly change the Employers of the tenderer's risks and responsibilities under the contract, or
- Affect the competitive position of the other tenderers presenting responsive tenders, if it were to be rectify.

F3.9 Arithmetical errors, omissions and discrepancies

The Employer reserves the right to correct any arithmetical or other errors in the calculation of the Tender amount.

The Tenderer will be notified accordingly prior to his tender being accepted. Under no circumstances will the unit rates be adjusted. Where any discrepancy exists between the unit price and the extended total against any item, the discrepancy will be adjusted by altering the total amount filled in against such item and consequently the total tendered sum

In the event of there being any rate or rates which are declared to be unacceptable by the Employer for reasons which the Employer will indicate, the tenderer will be requested to –

- a) Justify any specific rate or rates, i.e. to give a financial breakdown of how such rate or rates were obtained, and subsequently
- b) Consider amending and adjusting such rate or rates. It must be understood that in the event of the Tenderer refusing to adjust any rate or rates to the satisfaction of the Employer such refusal may prejudice his Tender.
- c) Where there is a discrepancy between the amounts in figures and in words, the amount in words shall govern.

Consider the rejection of a tender offer if the tenderer does not correct or accept the correction of his arithmetical errors in the manner described above.

F.3.10 Clarification of a tender offer

Obtain clarification from a tenderer on any matter that could give rise to ambiguity in a contract arising from the tender offer.

Municipality 1		Municipality 2		Contractor	
----------------	--	----------------	--	------------	--

F3.11

Evaluation of tender Offers

Tender offers will be evaluated on Method 4: Financial Offer, Quality and Preferences

<p>Method 4: Financial offer, quality & preferences</p>	<ol style="list-style-type: none"> 1) Score quality, rejecting all tender offers that fail to score the minimum number of points for quality stated in the Tender Data. 2) Score tender evaluation points for financial offer. 3) Confirm that tenderers are eligible for the preferences claimed, and if so, score tender evaluation points for preferencing. 4) Calculate total tender evaluation points. 5) Rank tender offers from the highest number of tender evaluation points to the lowest.
	<ol style="list-style-type: none"> 6) Recommend tenderer with the highest number of tender evaluation points for the award of the contract, unless there are compelling and justifiable reasons not to do so.

F3.11.1

Scoring Financial Offers

The formula to be used in the scoring of the Financial offer will be

$$\text{Price PS} = 90 \left(1 - \frac{(Pt - Pmin)}{Pmin} \right)$$

- Where
- Ps = Point scored for price of tender under consideration
 - Pt = Rand value of Tender under consideration
 - Pmin = Rand value of the lowest responsive tender

F3.11.2

Functionality Requirements

(If the detail is not provided in the Returnable Schedules zero "0" points will be awarded for quality criteria and the tenderer will be considered to be inexperienced). Tenderers must comply with ALL criteria in order to advance to the next stage:

Municipality 1		Municipality 2		Contractor	
----------------	--	----------------	--	------------	--

Section 1: Patching; Section 2: Asphalt;
Section 3: Slurry & Micro Surfacing
Section 4: Single & Double Seals

<u>Technical Evaluation Criteria</u>			Weight	Minimum Score
Description of quality criteria & Sub-criteria				
<u>Capacity to execute work i.to Infrastructure and Resources:</u>				
Proof of ownership of equipment/ plant on company letterhead (Registration document or: letter of intent provided from Hiring company, on company letterhead)				
Walk behind Roller (Patching)	<u>Owned:</u> 2 points	<u>Hired:</u> 1 point	8	4
Rammer / Wacker	2 points	1 point		
Compressor	2 points	1 point		
Truck	1 point	1 point		
Paver (Asphalt)	<u>Owned:</u> 3 points	<u>Hired:</u> 2 points	10	6
Self-propelled Pneumatic Tyre Roller	3 points	2 points		
Truck	1 points	1 point		
Milling Machine	3 points	2 points		
Slurry Machine or specialized plant required for Slurry / Micro surfacing (specify)	<u>Owned:</u> 4 points	<u>Hired:</u> 3 points	10	6
Compressor	3 points	2 points		
Truck	3 points	3 points		
Truck	<u>Owned:</u> 1 point	<u>Hired:</u> 1 point	10	6
Self-propelled Pneumatic Tyre Roller	3 points	2 points		
Loader	3 points	2 points		
Chip Spreader (Single seals)	3 points	2 points		
<u>Key Personnel/Project Team – CV's and Certified qualifications to be provided. (Personnel as listed must be the site team)</u>				
Job Description:	Min. Required Qualification	Min. Experience	4	3
Project / Site Agent/ Manager	National Diploma	5 years - 3 points		
Safety Officer	Accredited Safety Qualification	3 years - 1 point		
<u>Tendering Company's Experience</u>				
Previous experience – similar project experience as the work tendered for with completion certificates and appointment/works orders attached.				
	List three (3) similar projects with a minimum value of R 2,000,0000 each, during the last 5 years (1 point per project).	3 points	9	3
	Completion certificate and appointment letter/ works order to be provided for each project as listed above (2 points per project).	6 points		
The maximum number of points that can be scored			51	28
For the purpose of comparison and in order to ensure a meaningful evaluation, bidders are requested to furnish detailed information on substantiation of compliance to the evaluation criteria. The service provider should at least score a minimum of 28 points out of the 51 points in order to be considered in the next evaluation phase. Bidders who scores zero (0) for any of the 3 categories or individual Sections, during this stage will not be considered for the next stage of evaluation.				

Municipality 1		Municipality 2		Contractor	
----------------	--	----------------	--	------------	--

F3.11.3 Scoring B-BBEE Preferences

(If the detail is not provided in the Returnable Schedules zero "0" points will be awarded)

<u>B-BBEE Status Level of Contributor</u>	<u>Number of Points</u>
Level 1	10
Level 2	9
Level 3	8
Level 4	5
Level 5	4
Level 6	3
Level 7	2
Level 8	1
Non-compliant contributor	0

Table taken from Government Gazette Notice 34350 (8 June 2010) Unincorporated JV's will be evaluated on their consolidate B-BBEE level grading in terms of Clause 11(7).

F3.13.1 Acceptance of Tender Offer.

Tender offers will only be accepted as responsive if:

- a) the tenderer has in his or her possession an original valid Tax Clearance Certificate issued by the South African Revenue Services
- b) the tenderer has in his or her possession an valid B-BBEE Compliance Certificate issued by an Accredited Service Provider
- c) the tenderer is registered with the Construction Industry Development Board (CIDB) in an appropriate contractor grading designation;
- d) the tenderer or any of its directors is not listed on the Register of Tender Defaulters in terms of the Prevention and Combating of Corrupt Activities Act of 2004 as a person prohibited from doing business with the public sector; and
- e) the tenderer has not:
 - i) abused the Employer's Supply Chain Management System; or
 - ii) failed to perform on any previous contract and has been given a written notice to this effect

The employer reserves the right to accept any Tender or part thereof or to make no award at all. The lowest tender will thus not necessarily be accepted. The employer also reserves the right to award any part of the tender to any Tenderer. No reasons for the acceptance or rejection of a tender will be given.

F3.18 Signed Copies of Contract

The number of paper copies of the signed contract to be provided by the employer is one.

F3.19 Provide written reasons for actions taken

The Employer may withhold information with regard to action taken under certain .conditions: e.g

- a) It is not in the public interest to divulge
- b) Is considered to prejudice the legitimate interest of tenders; or
- c) Might prejudice fair competition between tenders

Municipality 1		Municipality 2		Contractor	
----------------	--	----------------	--	------------	--

PART T 2 : RETURNABLE DOCUMENTS

Municipality 1		Municipality 2		Contractor	
----------------	--	----------------	--	------------	--

T2.1: LIST OF RETURNABLE DOCUMENTS

The tenderer must complete the following returnable documents:

1 Returnable Schedules required only for tender evaluation purposes

- Record of Addenda to Tender Documents
- Certificate of Authority for Signatory
- Certificate of Authority for Joint Ventures (where applicable)
- Schedule of the Tenderer's Experience including design professional appointed as sub contractor
- Evaluation schedules
- Proof of registration for Contractor's WCA registration
- Certificate of Contractor Registration issued by the Construction Industry Development Board
- An original valid Tax Clearance Certificate issued by the South African Revenue Services.
- Annex A, B: Contract Participation Goal.

2 Other documents required only for tender evaluation purposes

If the Tenderer wishes to submit an alternative tender offer, all information must be submitted as per Clause F2.12 of the Tender Data as specified under Part 1: Tender Procedure.

3 Returnable Schedules that will be incorporated into the contract

- Preferencing Schedule
- CV's of key personnel
- Rates for Special Materials
- Components of the Safety Plan (see Health & Safety Specification – Part C3: Scope of Work)
- Preliminary Programme with defined Milestones, Method Statement and Quality Management Plan
- Compulsory Enterprise Questionnaire
- Schedule of Proposed Subcontractors
- Schedule of Construction Equipment
- Estimated Monthly Expenditure
- Safety and Fire Rules
- Occupational Health and Safety Questionnaire
- Schedule of Information (Banking Details etc.)
- Retention Money Guarantee
- Form of Bond
- Proposed Amendments and Qualifications
- Tendered contract participation goal

4 C1.1 The "Offer" portion of C1.1: Form of Offer and Acceptance

5 C1.2 Part 2 of C1.2: Contract Data

6 C2.2 Bills of quantities

Municipality 1		Municipality 2		Contractor	
----------------	--	----------------	--	------------	--

T2.2 LIST OF RETURNABLE SCHEDULES TO BE COMPLETED

The following Schedules must be completed in full during tendering. Incomplete forms may lead to disqualification of a tender.

SCHEDULE	Description	Page no
SCHEDULE A	Record of Addenda & Alterations by Tenderer	
SCHEDULE B1	Compulsory Enterprise Questionnaire	
SCHEDULE B2	Compulsory Bank Detail Questionnaire	
SCHEDULE B3	MCLM Corporate Social Responsibility	
SCHEDULE C	Authority to Sign	
SCHEDULE D1	Schedule of Similar Work Completed	
SCHEDULE D2	Schedule of Current Projects	
SCHEDULE E1	Schedule of Contractor's Staff including CV's	
SCHEDULE E2	Schedule of Subcontractors	
SCHEDULE F	Schedule of Plant	
SCHEDULE G	Schedule of Labour	
SCHEDULE H	Tax Certificate Requirements	
SCHEDULE I	Tax Clearance application	
SCHEDULE J	Proof of Registration of B-BBEE Certification	
SCHEDULE K	Proof of Registration of Workman's Compensation	
SCHEDULE L	Proof of Registration issued by CIDB	
SCHEDULE M	Municipal account – not older than 3 months	
MBD 4	Declaration of Interest (MBD 4)	
MDB 6.1	Claiming of Preference Points (MDB 6.1)	
MBD 8	Tenderer's Past Supply Chain Management Experience (MBD 8)	
MBD 9	Certificate of Independent Bid Determination (MBD 9)	
	Rates for Special Material	
	Preliminary Program with defined Milestones	
	Estimated Monthly Expenditure	
	Occupational Health & Safety Questionnaire	
	<u>Agreements & Contract Data</u>	
	Form of Offer and Acceptance ("Offer Portion) & Annexure	
	<u>Pricing Data</u>	
	Schedule of Quantities	

Municipality 1		Municipality 2		Contractor	
----------------	--	----------------	--	------------	--

SCHEDULE A : RECORD OF ADDENDA AND ALTERATIONS/QUALIFICATIONS BY TENDERER

Any Addenda received by the tenderer should be indicated in this schedule (and attached to this page)

Should the Tenderer desire to make any departures from or modifications to the General Conditions of Contract, the Special Conditions of contract, Specifications, Schedule of Quantities or Drawings, or to qualify his tender in any way, he shall set out his proposals clearly hereunder or alternatively state them in a covering letter attached to his tender and referred to hereunder, failing which the tender will be deemed to be unqualified.

DATE	ADDENDA NO	DESCRIPTION
PAGE	CLAUSE OR ITEM	PROPOSAL

TENDERER

DATE

Municipality 1		Municipality 2		Contractor	
----------------	--	----------------	--	------------	--

SCHEDULE B 1: COMPULSORY ENTERPRISE QUESTIONNAIRE

The validity of the information supplied in this document will be verified before the contract is awarded to the selected Contractor

The Contractor **must** supply the following information.

The following particulars must be furnished. In the case of a joint venture, **separate** enterprise questionnaires in respect of each partner

Section 1: Name of enterprise:

Section 2: VAT registration number, if any:.....

Section 3: CIDB registration number, if any:.....

Section 4: Particulars of sole proprietors and partners in partnerships

Name*	Identity number*	Personal income tax number*	% Shareholding

* Complete only if sole proprietor or partnership and attach separate page if more than 3 partners

Section 5: Particulars of companies and close corporations

Company registration number

Close corporation number.....

Tax reference number.....

Section 6: Turnover – Approximate turnover for each of the past three years

Year 2018 R_____

Year 2019 R_____

Year 2020 R_____

Anticipated turnover for 2021 R_____

Municipality 1		Municipality 2		Contractor	
----------------	--	----------------	--	------------	--

Section 7: Management and Manpower Resources

Number of Supervisors _____

Number of Labourers _____

Number of Operators _____

Other Personnel (Specify) _____

Total number permanent employees _____

Total number contract employees _____

Section 8: Record of service of the state

Indicate by marking the relevant boxes with a cross, if any sole proprietor, partner in a partnership or director, manager, principal shareholder or stakeholder in a company or close corporation is currently or has been within the last 12 months in the service of any of the following:

- | | |
|------------------------------------------------------------------------------------------------|---------------------------------------------------------------------------------------------------------------------------------------------------------------------------------------------------------------------|
| <input type="checkbox"/> A member of any municipal council | <input type="checkbox"/> An employee of any provincial department, national or provincial public entity or constitutional institution within the meaning of the Public Finance Management Act, 1999 (Act 1 of 1999) |
| <input type="checkbox"/> A member of any provincial legislature | <input type="checkbox"/> A member of an accounting authority of any national or provincial public entity |
| <input type="checkbox"/> A member of the National Assembly or the National Council of Province | <input type="checkbox"/> An employee of Parliament or a provincial legislature |
| <input type="checkbox"/> A member of the board of directors of any municipal entity | |
| <input type="checkbox"/> An official of any municipality or municipal entity | |

If any of the above boxes are marked, disclose the following:

Name of sole proprietor, partner, director, manager, principal shareholder or stakeholder	Name of institution, public office, board of organ of state and position held	Status of service (tick appropriate column)	
		Current	Within last 12 months

*insert separate page if necessary

Municipality 1		Municipality 2		Contractor	
----------------	--	----------------	--	------------	--

SCHEDULE B 2: COMPULSORY BANK DETAILS
(Attach cancelled cheque)

THE FOLLOWING FORM MUST BE COMPLETED BY THE TENDERERS BANK AND AN ORIGINAL BANK STAMP MUST BE AFFIXED TO THIS PAGE. NON-COMPLIANCE MAY DISQUALIFY THE TENDER

(Note: Each member of a Joint Venture (JV) must complete a Bank Detail form)

TENDER NO: PWRT (R&T)R&T)05/2021

PROJECT: TENDER FOR REHABILITATION AND RESURFACING OF ROADS ON AS PER THE ANNUAL ROADS PROJECT PLANS OVER A PERIOD OF 36 MONTHS

BANK DETAILS

I/we hereby request and authorize my/our Banker as detailed below to verify and supply a bank Code for my/our account. A Bank rating certificate is required to evaluate the Tenderers financial stability.

I/we also hereby acknowledge that the bank details as given can be verified independently by Mogale City Local Municipality's appointed Consultant on the Project: Pro-Plan Consulting Engineers (Pty) Ltd.

Initials & Surname	Authorized Signatory	Date (yyyy/mm/dd)
Account Holder		
Bank		
Branch		
Branch code		
Account Number		

Type of Account: Cheque Account Transmission Account Saving Account Other _____

Tender Amount R_____ Construction Period: _____ (months)

To be completed by the Bank

Initials & Surname (Bank Official)	Signature (Bank Official)	Date
Telephone Number (Bank Official)	<u>Date Stamp of Bank Certified as Correct or copy from the bank if applicable</u>	
Bank Code based on Tender Amount & Construction Period		

Municipality 1		Municipality 2		Contractor	
----------------	--	----------------	--	------------	--

Confidential

SCHEDULE B3 : MCLM CORPORATE SOCIAL RESPONSIBILITY

Mogale City Corporate Social Responsibility

In terms of Mogale City Corporate Responsibility, non Mogale City based Services Providers will contribute 1% of the Contract value to Mogale City.

Please attach the Certificate of Confirmation (CM29) as issued by the Registrar of Companies & Close Corporations, for this Tenderer to this page.

Please provide your registered address:

.....

.....

.....

Please indicate if you are a Mogale based:

YES	NO
-----	----

If not Mogale City based, a person duly authorized by the tenderer must complete and sign the declaration herewith in detail.

Declaration by Tenderer

I, the undersigned hereby declare and confirm that we accept the contribution towards the Mogale City Corporate Social Responsibility, by the deduction of one percent (1%) on all payment made.

Signed Date:

Name: Position:

Tenderer

Municipality 1		Municipality 2		Contractor	
----------------	--	----------------	--	------------	--

SCHEDULE C : AUTHORITY TO SIGN DOCUMENTS

Indicate the status of the tenderer by ticking the appropriate box hereunder. The tenderer must complete the certificate set out below for the relevant category. Delete whichever is inapplicable.

A Company	B Partnership	C Joint Venture	D Sole Proprietor	E Close Corporation
--------------	------------------	--------------------	----------------------	------------------------

The following documentation must be provided in all categories

Certified Copy of Extract from Minutes
Company Documentation

A. Certificate for company

I,....., chairperson of the board of directors of
....., hereby confirm that by resolution of the board taken on
..... 20.....,
Mr/Ms....., acting in the capacity of, was
authorised to sign all documents in connection with this tender and any contract resulting from it on behalf of
the company.

As witnesses:-

- | | | |
|----|------------------|-------------------|
| 1. |
Witness |
Chairman |
| 2. |
Witness |
Date |

B. Certificate for partnership

We, the undersigned, being the key partners in the business trading as hereby
authorise Mr/Ms, acting in the capacity of, to sign all
documents in connection with the tender for Contract and any contract resulting
from it on our behalf.

NAME	ADDRESS	SIGNATURE	DATE

Municipality 1		Municipality 2		Contractor	
----------------	--	----------------	--	------------	--

NOTE: This certificate is to be completed and signed by all of the key partners upon whom rests the direction of the affairs of the Partnership as a whole.

C. Certificate for Joint Venture

We, the undersigned, are submitting this tender offer in Joint Venture and hereby authorise Mr/Ms, authorised signatory of the company, acting in the capacity of lead partner, to sign all documents in connection with the tender offer for Contract and any contract resulting from it on our behalf.

This authorisation is evidenced by the attached power of attorney signed by legally authorised signatories of all the partners to the Joint Venture.

NAME OF FIRM	ADDRESS	AUTHORIZING SIGNATURE, NAME & CAPACITY
--------------	---------	----------------------------------------

Municipality 1		Municipality 2		Contractor	
----------------	--	----------------	--	------------	--

Lead Partner (Partner 1) CIDB Reg No: _____ CIDB Grading: _____		Signature: _____ Name: _____ Position: _____
Partner 2 CIDB Reg No: _____ CIDB Grading: _____		Signature: _____ Name: _____ Position: _____
Partner 3 CIDB Reg No: _____ CIDB Grading: _____		Signature: _____ Name: _____ Position: _____
Partner 4 CIDB Reg No: _____ CIDB Grading: _____		Signature: _____ Name: _____ Position: _____

Municipality 1		Municipality 2		Contractor	
----------------	--	----------------	--	------------	--

D. Certificate for sole proprietor.

I, hereby confirm that I am the sole owner of the business trading as

.....

As witnesses:-

1.
 Witness Signature: Sole owner

2.....
 Witness Date

E. Certificate for Close Corporation

We, the undersigned, being the key members in the business trading as hereby authorise Mr/Ms, acting in the capacity of, to sign all documents in connection with the tender for Contract and any contract resulting from it on our behalf.

NAME	ADDRESS	SIGNATURE	DATE

NOTE: This certificate is to be completed and signed by all of the key members upon whom rests the direction of the affairs of the Close Corporation as a whole.

Municipality 1		Municipality 2		Contractor	
----------------	--	----------------	--	------------	--

SCHEDULE D.1 : SCHEDULE OF SIMILAR WORK COMPLETED BY TENDERER

The Tenderer must insert in the space provided below, a list of projects completed in the past five (5) years by his firm. Should no details be entered it will be assumed that the Tender has been submitted by an inexperienced Tenderer and cannot be rated as competent. *Contact details for referrals to be correct. Please described work done in detail. Additional pages may be used with Completion Certificates.*

CLIENT	CONTACT PERSON & TELEPHONE NUMBER	DETAIL SCOPE OF WORK	VALUE OF CONTRACT	YEAR COMPLETED	COMPLETION CERTIFICATE ATTACHED	SIGNATURE

SIGNED ON BEHALF OF TENDERER

DATE

Municipality 1		Municipality 2		Contractor	
----------------	--	----------------	--	------------	--

SCHEDULE D.2 : SCHEDULE OF CURRENT PROJECTS

CLIENT	DETAIL SCOPE OF WORK	VALUE OF CONTRACT	EXPECTED COMPLETION DATE

*** Attach Completion Certificates to the front of this page ***

SIGNED ON BEHALF OF TENDERER

DATE

Municipality 1		Municipality 2		Contractor	
----------------	--	----------------	--	------------	--

SCHEDULE E1 : SCHEDULE OF CONTRACTOR'S STAFF ASSIGNED TO PROJECT

According to the requirements of the Project Specifications contained in this Tender, the tenderer must indicate details of staff together with their qualifications he intends using should he be awarded this Contract:-

Experience of the key staff (assigned personnel) in relation to the scope of work will be evaluated from three different points of view:

1. General experience (total duration of professional activity), level of education and training and positions held of each key staff member / expert member.
2. The education, training and experience of the key staff members / experts, in the specific sector, field, subject, etc which is directly linked to the scope of work.
3. The key staff members / experts knowledge of issues which the tenderer considers pertinent to the project e.g. local conditions, affected communities, legislation, techniques, etc.

CV's of individual Team member MUST be completed and attached to the CV template page provided on the next page.

Name	Job Title	Years In this Position	Experience and Qualifications. <i>Attach Certificates; Operator's License etc.</i>
	Project / Site Manager		
	Safety officer		
	Plant Operator		Valid Operators License YES / NO
	Contract Manager		
	Other:		

SIGNED ON BEHALF OF TENDERER

DATE

Municipality 1		Municipality 2		Contractor	
----------------	--	----------------	--	------------	--

CV TEMPLATE - CONTRACTORS STAFF ASSIGNED TO THE PROJECT

A CV of each key staff member of not more than 2 pages should be attached to this schedule. The CV should be structured under the following headings:

1.	Personal particulars
	<ul style="list-style-type: none"> • Name • Date and place of birth • Place (s) of tertiary education and dates associated therewith • Professional awards
2.	Qualifications (degrees, diplomas, grades of membership of professional societies and professional registrations)
3.	Name of current employer and positions in enterprise
4.	Overview of post graduate / diploma experience (year, organization and position)
5.	Outline of recent assignments / experience that has a bearing on the scope of work – List 3 projects in the past 5 years the person worked on in the position indicated.

***** Attach CV's of Key Personnel to the front of this page *****

Municipality 1		Municipality 2		Contractor	
----------------	--	----------------	--	------------	--

SCHEDULE E2: SCHEDULE OF PROPOSED SUBCONTRACTORS

This schedule is to notify the Client that it is the intention of the contractor to employ the following subcontractors for work on this contract. Contractors are required to subcontract with local contractors on Mogale City Local Municipality's Database (See attached list)

Name & Tel of Proposed Subcontractor	Nature & Extent of Work	Estimated Value of Work
Tel:		
Tel:		
Tel:		
Tel:		
Tel:		
Tel:		

SIGNED ON BEHALF OF TENDERER

DATE

Municipality 1		Municipality 2		Contractor	
----------------	--	----------------	--	------------	--

SCHEDULE F: LIST OF PLANT

The Tenderer must indicate below what plant he has readily available, or will be hired for use on the Works should his Tender be accepted.

Attach Proof of ownership / registration numbers / letters of intent to the front of this page

DESCRIPTION, SIZE AND CAPACITY	QUANTITY
(A) AVAILABLE (OWN PLANT) – Proof to be provided of ownership	
(b) TO BE HIRED – Letter of Intent to be provided	

TENDERER

DATE

Municipality 1		Municipality 2		Contractor	
----------------	--	----------------	--	------------	--

SCHEDULE G : DAYWORK SCHEDULE

The Tenderer must enter a rate which will be applicable to all daywork executed by him. This rate must cover all overheads, profit, administration, insurance, supervision, etc, as well as any equipment which may be required.

Daywork may only be done after the written approval has been obtained from the Engineer as no payment will be considered should the approval not be obtained. (Refer to Schedule of Quantities)

WORKER	RATE PER HOUR
LABOUR Foreman Charge Hand Skilled Artesian Unskilled Artesian Semi-skilled Worker Worker _____	_____ _____ _____ _____ _____ _____
PLANT (Tenderer to specify)Model.....Model.....Model.....Model.....	PLANT

N/A REFER TO BILL OF QUANTITIES FOR RATES

TENDERER

DATE

Municipality 1		Municipality 2		Contractor	
----------------	--	----------------	--	------------	--



SCHEDULE I : B-BBEE CERTIFICATION

Tenderers Company Name	
B-BBEE Level	
Expiry Date	

Copy of B-BBEE Certification to be attached to the front of this page

SIGNED ON BEHALF OF TENDERER

DATE

Municipality 1		Municipality 2		Contractor	
----------------	--	----------------	--	------------	--

SCHEDULE J : REGISTRATION AND WORKMAN'S COMPENSATION COMMISSIONER

Tenderers Company Name	
WCC Registration Number	
Expiry Date	

Copy of Letter of Good Standing to be attached to the front of this page

SIGNED ON BEHALF OF TENDERER

DATE

Municipality 1		Municipality 2		Contractor	
----------------	--	----------------	--	------------	--

SCHEDULE K : REGISTRATION AT CONSTRUCTION INDUSTRY DEVELOPMENT BOARD (CIDB)

Tenderers Company Name	
CIDB Registration Number	
Contractors Grading	

Copy of CIDB Registration to be attached to the front of this page

SIGNED ON BEHALF OF TENDERER

DATE

Municipality 1		Municipality 2		Contractor	
----------------	--	----------------	--	------------	--

SCHEDULE L : MUNICIPAL ACCOUNT

Tenderers Company Name	
Municipal Account Holder	
Account Holders Position in Company	
Municipal Account Number	

Copy of latest Municipal Account in the name of the Business (not older than 3 months) to be attached to the front of this page

SIGNED ON BEHALF OF TENDERER

DATE

Municipality 1		Municipality 2		Contractor	
----------------	--	----------------	--	------------	--

Rates for Special Materials

Tenderer to Specify

SPECIAL MATERIAL	UNIT*	RATE OR PRICE FOR THE BASE MONTH
Bitumen Related Products		
SBR		
Polymer		
Rubber		

*Indicate whether the material will be delivered in bulk or in containers.

When called upon to do so, the tenderer shall substantiate the above rates or prices with acceptable documentary evidence.

Tenderer to Specify

SPECIAL MATERIAL	UNIT*	RATE OR PRICE FOR THE BASE MONTH

Signed _____

Date _____

Name _____

Position _____

Municipality 1		Municipality 2		Contractor	
----------------	--	----------------	--	------------	--

Tenderer

Preliminary Program, Method Statement and Quality Management Plan

The Tenderer shall attach a Preliminary Program, reflecting the proposed sequence, duration and milestones of execution of the various activities comprising the work for this contract. The program shall be in accordance with the information provided in the Schedule of Constructional Equipment and with all other relevant aspects of the tender.

The Tenderer shall attach a Method Statement that adequately details all activities, durations and any associated risks in terms of operations envisaged on this contract.

The Tenderer shall also attach his Quality Management Plan showing clearly how quality assurance and process control will be managed both at the plant and on site. The plan will be used to evaluate the tenders as the quality of workmanship is of highest priority in this contract. Any quality certification by recognized international body must be stated.

Signed _____

Date _____

Name _____

Position _____

Tenderer _____

Municipality 1		Municipality 2		Contractor	
----------------	--	----------------	--	------------	--

Estimated Monthly Expenditure

The Tenderer shall state his estimated value of the work to be completed every month, based on his preliminary program and his Tendered value, in the table below. VAT is not to be included.

To be supplied within 14 days of receiving an order.

MONTH	VALUE
1.	R
2.	R
3.	R
4.	R
5.	R
6.	R
7.	R
8.	R
9.	R
10	R
11.	R
12	R
TOTAL:R	

Signed _____

Date _____

Name _____

Position _____

Tenderer _____

Municipality 1		Municipality 2		Contractor	
----------------	--	----------------	--	------------	--

PART C1 : AGREEMENTS & CONTRACT DATA

The forms of agreement and surety bonds shall be in accordance with the forms bound in this section of the document.

	Page no
C1.1 Form of Offer	
C1.2 Form of Acceptance	
C1.3 Contract Data	
C1.4 Construction Guarantee (Performance Guarantee)	
<i>Following Agreements will be completed on award of Tender</i>	
Agreement in Terms of the OSH Act	
Notification of Construction Work	
Agreement to Accept Terms of EMP	
Bond for material on site	
Bond for material not on site	
Ownership of materials	

Municipality 1		Municipality 2		Contractor	
----------------	--	----------------	--	------------	--



C1.1 FORM OF OFFER

(NOTE : THE APPENDIX, ANNEXURES & REPORTS FORM PART OF THE TENDER)

THIS FORM MUST BE FILLED IN BY THE TENDERER AND MUST BE SIGNED AT TIME OF SUBMISSION OF THE TENDER

The Employer identified in the Acceptance signature block has solicited offers to enter into a contract for:

TENDER NO : **PWRT (R&T) 052021**

DESCRIPTION OF WORKS : **REHABILITATION AND RESURFACING OF ROADS ON AS PER THE ANNUAL ROADS PROJECT PLANS OVER A PERIOD OF 36 MONTHS**

The Tenderer, identified in the Offer signature block, has examined the General and the Special Conditions of Contract, Specifications, Drawings, and Schedule of Quantities for the works:

CONSTRUCTION OF SURFACE SEALS, ASPHALT BASE AND SURFACINGS ON AN AS AND WHEN REQUIRED BASIS FOR A PERIOD OF THIRTY SIX (36) MONTHS. I/We offer to construct, complete and remedy any defects in the said Works in conformity with the General and the Special Conditions of Contract, Specifications, Drawings and Schedule of Quantities, save as amended by Alterations by Tenderer (if any) attached hereto, for the sum of:

Description	Amount	Vat @ 15%	Amount (Incl. VAT)
REHABILITATION AND RESURFACING OF ROADS AS PER THE ANNUAL ROADS PROJECT PLANS OVER A PERIOD OF 36 MONTHS:			
P&G's & ROAD MARKING			
SECTION 1			
SECTION 2			
SECTION 3			
SECTION 4			
Sub Total			

In words _____

or such other sum as may be ascertained in accordance with the terms of the contract.

Our proposed construction period as from site handover :

Description	Section	Start date	End date	Construction Period (Weeks)
REHABILITATION AND RESURFACING OF ROADS ON AS PER THE ANNUAL ROADS PROJECT PLANS OVER A PERIOD OF 36 MONTHS				

Tenderer Name _____ *Tenderer Signature* _____

Municipality 1		Municipality 2		Contractor	
----------------	--	----------------	--	------------	--

Form of Offer (Continued)

My/Our offer/s remains binding upon me and open for acceptance by the purchaser/client during the validity period (90 days) indicated and calculated from the closing time of tender.

1. The following documents shall be deemed to form and be read and construed as part of this agreement:

- (i) Tender documents, viz
 - Invitation to tender
 - Tender Data
 - Returnable Schedules (Schedule D)
 - Technical Data Sheets
 - Preference claims in terms of the Preferential Procurement Regulations 2001
 - Declaration of interest
 - Contract Data
 - Special Conditions of Contract;
 - Pricing schedule(s)
 - Scope of Works
 - Site Information

- (ii) General Conditions of Contract; (GCC 2015) and
- (iii) Drawings
- (iv) Annexures
- (v) Addendums
- (vi) Other _____

2. Deviations from and amendments to the documents listed in the Tender Data and any addenda thereto as listed in the Tender Schedules as well as any changes to the terms of the Offer agreed by the Tenderer and the Employer during this process of offer and acceptance, are contained in the Schedule of Deviations attached to and forming part of this Agreement. No amendments to or deviations from said documents are valid unless contained in this Schedule, which must be duly signed by the authorized representative (s) of both parties.

3. I/We confirm that we have satisfied ourselves as to the correctness and validity of my tender; that the price(s) and rate(s) quoted cover all the goods and/or works specified in the bidding documents; that the price(s) and rate(s) cover all my obligations and I/We accept that any mistakes regarding price(s) and rate(s) and calculations will be at my/our own risk.

In the event of there being any errors of extension or addition in the priced Schedule of Quantities, I/We/we agree to their being corrected by you or by the Engineer acting on your behalf, the rates being taken as correct and the tender amount be adjusted accordingly.

Tenderer Name _____ Tenderer Signature _____

Municipality 1		Municipality 2		Contractor	
----------------	--	----------------	--	------------	--

Form of Offer (Continued)

- 4. I/We confirm that Escalation will be applicable on Special Materials on this contract and will be calculated as per Contract Data & General Conditions of Contract 2015 (GCC 2015)
- 5. I/We accept full responsibility for the proper execution and fulfillment of all obligations and conditions devolving on me under this agreement as the principal liable for the due fulfillment of this contract. I/We undertake to complete and deliver the whole of the Works comprised in the Contract within the time stated in the Appendix adjusted in terms of the Contract.
- 6. The Tenderer shall within two weeks after receiving a completed copy of this Agreement, including the Schedule of Deviations (if any), contact the Employer's Agent (whose details are given in the Contract Data) to arrange the delivery of any bonds, guarantees, proof of insurance and any other documentation to be provided in terms of the Conditions of Contract identified in the Contract Data. Failure to fulfill any of these obligations in accordance with those terms shall constitute a repudiation of this Agreement.

The Construction /Performance Guarantee that I/We propose is: _____

From (Insurer Name)*1 _____

*1 – Letter of Intent to be provided

- 7. Unless and until a formal agreement is prepared and executed, this Tender, together with the written acceptance thereof by yourselves or the Engineer acting on your behalf, shall constitute a binding Contract between us.
- 8. I/We* understand that you are not bound to accept the lowest or any tender you may receive.
- 9. I/We* confirms that he/she is aware of the suspense condition that the tender amount as mentioned in the tender document is subject to availability of funds to cover the total envisaged expenditure for the tender in question and
- 10. I/We* further confirms that Mogale City Local Municipality has the right to cancel the tender prior to award if the funds necessary to cover the total envisaged expenditure of the tender are not available for the current financial year; Mogale City Municipality has the right to reduce the Scope of Work after award and prior to commencement to comply with the available budget
- 11. I/We declare that I/We have no participation in any collusive practices with any tenderer or any other person regarding this or any other tender.

Tenderer Name _____ Tenderer Signature _____

Municipality 1		Municipality 2		Contractor	
----------------	--	----------------	--	------------	--

Form of Offer (Continued)

12. I/We, declare that we fully and unconditionally accept the full authority of the engineer as the representative of the client on site and understand that any communications to the Municipality can only be done through the engineer, unless, otherwise instructed / authorised by the engineer. Any disputes between myself, the contractor, and the engineer will be dealt with by the project manager of the municipality working on the particular project.

13. I/we declare that I/we completely waiver our right of Lien and that no property what so ever will be taken ownership off. The site and all applicable materials paid for in full, remain unconditionally the property of the municipality and I/we have at no stage took ownership of such site and materials

14. I/We confirm that I/We am duly authorized to sign this contract.

NAME (PRINT)

CAPACITY

SIGNATURE

NAME OF COMPANY

DATE

WITNESSES	
1
2.
DATE:

Municipality 1		Municipality 2		Contractor	
----------------	--	----------------	--	------------	--

GENERAL CONDITIONS OF CONTRACT 2015 (GCC 2015)

CLAUSE

Special non-working days	5.8.1	The period 16 December to 5 January inclusive, plus Good Friday, Human Rights Day, Freedom Day, Workers Day and Youth Day
Estimated Construction Period	5.1	• _____ weeks <i>Max 8 months</i>
Amount of penalty	5.13	To a maximum of R2 500-00 per calendar day
Percentage advance on material not yet built into the Permanent Works	6.10.1.5	80 percent
Percentage retention	6.10.3	10 percent
Limit of retention money	6.10.3	10 percent of tender amount (excl VAT & contingencies & escalation if applicable) to be deducted from each payment certificate
Retention Money Guarantee	8.6.1.5	Not permitted
Delivery of Contractor's final statement	6.10.8	Within 14 days after certified date of completion of Works
Defects Liability Period	7.8	12 (twelve) months
Settlement of disputes to be by reference	10.7	Arbitration - Refer to clause Special Conditions of Contract
Contract Price Adjustment Schedule (only applicable to contracts of 12 months and longer)	6.8.2	Contract Price Adjustment Schedule (SAFCEC) Coefficients for calculating Contract Price Adjustment Factor: (Refer to Contract Data) x = 0,10 <i>(New Road construction – Urban Roads (a) Including Bitumen)</i> aLt (Labour) = 0,25 bPt (Plant) = 0,15 cMt (Material) = 0,55 dFt (Fuel) = 0,05
	6.8.3	As per Schedule
Price variation of Special Materials		

SIGNATURE : _____

ON BEHALF OF : _____

DATE : _____

**If the time of completion is not stated the Contractor should fill in.*

Municipality 1		Municipality 2		Contractor	
----------------	--	----------------	--	------------	--



C1.2 FORM OF ACCEPTANCE

(To be completed by the Client – Mogale City Local Municipality on Tender Award)

By signing this part of this Form of Offer and Acceptance, the Employer identified below accepts the Tenderer's Offer. In consideration thereof, the Employer shall pay the Contractor the amount due in accordance with the Conditions of Contract identified in the Contract Data. Acceptance of the Tenderer's Offer shall form an agreement between the Employer and the Tenderer upon the terms and conditions contained in this Agreement and in the Contract that is the subject of this Agreement.

1. We in our capacities as:

<u>Department</u>	<u>Name</u>	<u>Signature</u>
Manager Legal Services :	_____	_____
Executive Manager Corporate Support Services	_____	_____
Executive Manager PUBLIC WORKS, ROADS AND TRANSPORT	_____	_____

accept your tender under reference number **TENDER NO PWRT (R&T) 05/2021** dated for **REHABILITATION AND RESURFACING OF ROADS ON AS PER THE ANNUAL ROADS PROJECT PLANS OVER A PERIOD OF 36 MONTHS** indicated hereunder and/or further specified in the SCHEDULE(s).

1. An official order/ Letter of Appointment indicating delivery instructions are forthcoming.
2. I undertake to make payment for the goods/works delivered/constructed in accordance with the terms and conditions of the contract, within 30 (thirty) days after receipt of an invoice accompanied by the Payment Certificate.

3.

Description	Section	Contract Value (Incl, VAT) (Arithmetically Correct Tender Amount)	Construction Period (Weeks)
REHABILITATION AND RESURFACING OF ROADS ON AS PER THE ANNUAL ROADS PROJECT PLANS OVER A PERIOD OF 36 MONTHS			

Municipality 1		Municipality 2		Contractor	
----------------	--	----------------	--	------------	--

Form of Acceptance (Continued)

4. I confirm that I am duly authorized to sign this contract.

SIGNED ATON.....

NAME (PRINT)

SIGNATURE

WITNESSES	
1.
2.
DATE

OFFICIAL STAMP

The tenderer shall within two weeks after receiving a completed copy of this agreement, including the schedule of deviations (if any), contact the Employer's agent (whose details are given in the Contract Data) to arrange the delivery of any bonds, guarantees, proof of insurance and any other documentation to be provided in terms of the Conditions of Contract identified in the Contract Data. Failure to fulfill any of these obligations in accordance with those terms shall constitute a repudiation of this agreement.

Notwithstanding anything contained herein, this agreement comes into effect on the date when the tenderer receives one fully completed copy of this document, including the schedule of deviations (if any). Unless the tenderer (now contractor) within five working days of the date of such receipt notifies the Employer in writing of any reason why he cannot accept the contents of this agreement, this agreement shall constitute a binding contract between the parties.

Municipality 1		Municipality 2		Contractor	
----------------	--	----------------	--	------------	--

Form of Acceptance (Continued)

Schedule of Deviations

Notes:

1. *The extent of deviations from the tender documents issued by the Employer prior to the tender closing date is limited to those permitted in terms of the Conditions of Tender,*
2. *A Tenderer's covering letter shall not be included in the final contract document. Should any matter in such, letter, which constitutes a deviation as aforesaid become the subjects of agreements reached during the process of, offer and acceptance, the outcome of such agreement shall be recorded here,*
3. *Any other matter arising from the process from offer and acceptance either as a confirmation, clarification or change to the tender documents and which it is agreed by the Parties becomes an obligation of the contract shall also be recorded here,*
4. *Any change of addition to the tender documents arising from the above agreements and recorded here, shall also be incorporated into the final draft of the contract.*

1 Subject
Details
.....
.....
.....
2 Subject
Details
.....
.....
.....
3 Subject
Details
.....
.....
.....
4 Subject
Details
.....
.....
.....

By the duly authorised representatives signing this agreement, the Employer and the tenderer agree to and accept the foregoing schedule of deviations as the only deviations from and amendments to the documents listed in the Tender Data and addenda thereto as listed in the tender schedules, as well as any confirmation, clarification or changes to the terms of the offer agreed by the tenderer and the Employer during this process of offer and acceptance.

It is expressly agreed that no other matter whether in writing, oral communication or implied during the period between the issue of the tender documents and the receipt by the tenderer of a completed signed copy of this Agreement shall have any meaning or effect in the contract between the parties arising from this agreement.

Form of Acceptance (Continued)

For the Tenderer:

Municipality 1		Municipality 2		Contractor	
----------------	--	----------------	--	------------	--

Signature(s) Date.....

Name(s)

Capacity

Name and

Address of

Organisation.....

Name and

Signature of witness Date.....

For the Employer:

Signature(s) Date.....

Name(s)

Capacity

Name and

Address of

Organization

Name and

Signature of witness Date.....

Municipality 1		Municipality 2		Contractor	
----------------	--	----------------	--	------------	--

C1.3 CONTRACT DATA

C1.3.1 General

Due to the specialized nature of the works it is envisaged that the bulk of the works will be done with specialized Construction equipment operated by the Contractor’s staff.

For activities which requires hand work or where additional labour is required, the Contractor will be required to make use of local labourers within Mogale City.

C1.3.2 Contract Documents

The following documents form part of this tender:

No	CONTENTS
1	This Tender Document consist of and in which is bound the Conditions of Tender, General Conditions of Contract, Mogale City Local Municipality Procurement Policy, Project Specifications, Schedule of Quantities, Form of Tender with Appendix, Form of Agreement, Returnable Schedules and Schedules of Quantities - all as listed in the Index.
2	The following publication will constitute The General Conditions of this Contract: “General Conditions of Contract for Construction Works – Third Edition [2015]” (GCC 2015) . The abovementioned document can be obtained from the South African Institution of Civil Engineers and/or the South African Federation of Civil Engineering Contractors. This document replaces GCC 1990 & 2004. This document is not bound in this the tender document and must be obtained from the South African Institution of Civil Engineers Tel (011) 648-1184.
3	Standardised specifications for Civil Engineering Construction SABS 1200 - not bound in this document and obtainable from: The South African Bureau of Standards, Private Bag X191, Pretoria, 2001.
4	Standardised specifications for Civil Engineering Construction SANS 1921 :2004 Construction and management requirements for Works Contracts - not bound in this document and obtainable from: The South African Bureau of Standards, Private Bag X191, Pretoria, 2001 or www.sabs.co.za
5	SANS 294 Construction Procurement & Processes, Procedures and Methods- not bound in this document and obtainable from: The South African Bureau of Standards, Private Bag X191, Pretoria, 2001 or www.sabs.co.za
6	Occupational Health and Safety Act No.85 of 1993 , (amended) and any and all regulations with regard to this Act – not bound into this document and obtainable from www.acts.co.za/ohs or Department of Labour at www.labour.gov.za Laboria House, 215 Schoeman Street, Pretoria / Private bag X117, Pretoria, 0001

Municipality 1		Municipality 2		Contractor	
----------------	--	----------------	--	------------	--

7	Basic Conditions of Employment Act of 1997 by the Minister of Labour in Government Notice No. R63 of 25 January 2002 shall apply to works described in the Scope of Work as being labour intensive and which are undertaken by unskilled and semi-skilled workers and can be obtained from Department of Labour at www.labour.gov.za Laboria House, 215 Schoeman Street, Pretoria / Private bag X117, Pretoria, 0001
8	Appropriate Development of Infrastructure on Dolomite (PW344) – June 2006 shall apply to all works executed in terms of this tender. Extract of the document is bound into this document but the complete document can be obtained from the Department of Public Works or at www.publicworks.gov.za
9	COLTO: Standard Specifications for Road and Bridge Works – 2017 Edition , published by COLTO (Committee of Land Transport Officials) and obtainable from the South African National Roads Agency Limited, PO Box 415, Pretoria, 0001. email Address info@nra.co.za ; http://www.nra.co.za/ <i>SABS 1200 takes preference and in absence of an appropriate SABS specification and if specified the applicable COLTO specification will be applicable</i>
10	A set of reduced drawings for tender purposes – bound into this document

C2.1.3 Signing of Tender & Form Of Tender

The Form of Tender must be signed by a person duly authorized to do so. A Tender submitted by a Corporation must carry the seal of Corporation and be signed by the Secretary.

A tender submitted by a Consortium of Companies must be accompanied by a registered agreement between the companies concerned with regard to the tender under consideration. The above document must include all relevant details of the agreement so that the function of the Consortium can be evaluated.

The Procurement Department will hold all authorized signatories liable on behalf of the tenderer. Signatories for tenderers proposing to contract as a Joint Venture shall state which of them is the lead partner whom the Procuring Department shall hold liable for the purpose of the tender offer. Joint Venture Agreement must be included in the tender document.

Tenders are to be made out on the Tender Form which is bound in this document and must not be detached, and the document must be fully priced, correctly extended and totaled in black ink and completed in all respects.

Failure to sign the Tender Form or alternatively to acknowledge and accept in writing the conditions contained therein may invalidate the Tender. This Tender, duly completed as set out above, together with any covering letters, and accompanied by the required deposit, must be enclosed in a sealed envelope bearing the name and address of the Tenderer, endorsed with the Tender Number and due date. Telegraphic tenders will not be accepted

Municipality 1		Municipality 2		Contractor	
----------------	--	----------------	--	------------	--

C1.3.4 Tenderer must be Competent

Only tenders from competent Tenderers will be considered. The Tenderer must indicate his relevant experience in the schedule (Schedule D) provided. If no information is provided, the tenderer will be considered as inexperienced in the work tendered for.

The Tenderers` ability to successfully carry out the Works shall be fully considered during the evaluation of Tenders. The Municipality shall take cognizance of the Tenderers` relevant experience, expertise and/or capacity, which are reasonably required for the successful execution and completion of the Works and may authorize an investigation into any specific Tenderer`s financial position, previous contracts executed, workmanship and skills, trade qualifications, current workload, honouring of financial obligations in respect of previous suppliers, sub-contractors and labourers or any other aspect that may be indicative of the Tenderer`s potential ability to complete the Works within the specified contract period.

C1.3.5 Sub-Contracting

Should it be proposed to subcontract any part of the work covered by the Tender, full details shall be given, including the name of the proposed sub-Contractor (SCHEDULE E2).

C1.3.6 Labour Intensive Construction (LIC)

Not applicable to this Contract as the bulk of the work will be done with Specialized Construction Equipment. Where possible labour must be recruited from within Mogale City District, except for the key personnel of the Contractor required for supervision.

Municipality 1		Municipality 2		Contractor	
----------------	--	----------------	--	------------	--

GENERAL CONDITIONS OF CONTRACT

The following publication will constitute The General Conditions of this contract:

“GENERAL CONDITIONS OF CONTRACT FOR CONSTRUCTION WORKS – THRID EDITION [2015]”. (GCC 2015)

The abovementioned documents have been prepared under the auspices of the South African Institution of Civil Engineers and the South African Federation of Civil Engineering Contractors and copies of these documents are obtainable from any of the above bodies. This document replaces **GCC 2010**

The Contractor must familiarize himself with the above document and must comply with it for the duration of the Tender.

The General Conditions of Contract for Construction Works make several references to the Contract Data for specific data, which together with these conditions collectively describe the risks, liabilities and obligations of the contracting parties and the procedures for the administration of the contract. The Contract Data shall have precedence in the interpretation of any ambiguity or inconsistency between it and the general conditions of contract.

C1.3.7 AMENDMENTS TO THE GENERAL CONDITIONS OF CONTRACT 2010 WITH CONTRACT SPECIFIC CONDITIONS.

Each item of data given below is cross-referenced to the clause in the General Conditions of Contract for Construction Works to which it mainly applies.

C1.3.8. CONTRACT SPECIFIC DATA.

The following definitions and conditions apply to this Tender and the only variations from the General Conditions of Tender are as follows:

Municipality 1		Municipality 2		Contractor	
----------------	--	----------------	--	------------	--

REFERENCE TO:	CLAUSE.	INFORMATION.
Commencement	1.1.5	<p>“Commencement Date” means the date of receipt by the Contractor of the following whichever date of receipt is the earliest:</p> <ol style="list-style-type: none"> 1. Letter of Appointment 2. Handover of Site 3. Order to commence <p>“Commencement of Work” will only take place once the following documentation was submitted to the office of the Consulting Engineer:</p> <ol style="list-style-type: none"> 1. Letter of Acceptance 2. Original Construction Guarantee 3. Letters of Appointment of Site Agent and OHS Rep 4. Construction Program 5. Registration of Project at Department of Labour 6. Letter of Good Standing – Workman's Compensation
Contractor.	1.1.1.9	<p><i>Name:</i></p> <hr/> <p><i>Address</i></p> <hr/> <hr/> <p><i>Contact:</i></p>
Employer.	1.1.1.15	<p>Mogale City Local Municipality</p> <p>The address for the Project manager is: Third Floor; President Building, President Street Krugersdorp Telephone: (011) 951-2103 Fax: (011) 660-9672 P.O. Box 94, KRUGERSDORP, 1740</p>
Engineer	1.1.1.16	Andre Botes
	3.1.3	<p>If the Engineers is not the Mogale City Local Municipality, he is in terms of his appointment by the Employer, required to obtain the specific approval of the Employer for the execution of the following duties:</p> <ol style="list-style-type: none"> (i) Nominating the Engineer's representative in terms of clause 3.2 (ii) Delegation of Engineer's authority in terms of clause 3.2.4 (iii) Providing consent for sub- contracting part of the contract in terms of clause 4.4.3 (iv) The issuing of further drawings or instructions in terms of clause 5.9.2 (v) The issuing of instructions for dealing fossils and the like in terms of clause 4.7

Municipality 1		Municipality 2		Contractor	
----------------	--	----------------	--	------------	--

		<ul style="list-style-type: none"> (vi) Authorizing the Contractor to repair and make good expected risks in terms of clause 8.3.1 (vii) The issuing of a variation order in terms of clause 6.3 (viii) The issuing of instructions to carry out the work on a day work basis in terms of clause 6.5 (ix) Granting permission to work during non-working times in terms of clause 5.8 (x) Suspend the progress of the works in terms of clause 5.11 (xi) The issuing of an instruction to accelerate progress in terms of clause 5.7.3 (xii) The reduction of a penalty for delay in terms of clause 5,13,2 (xiii) The giving of a ruling on a contractor's claim in terms of clause 10.1.5 (xiv) The inclusion of credits in the next payment certificate in terms of clause 6.10.1 (xv) The agreement of the adjustment of the sums for general items of clause 6.8 (xvi) The issuing of an order to suspend the progress of the Works, the extra cost resulting from which order is to be borne by the Employer in terms of Clause 5.10, or the effect of which is liable to give rise to a claim by the Contractor for an extension of time under Clause 10.1
Contract price	1.1.1.10	“Contract Price” means the Price tendered by the Contractor and accepted by Mogale City Local Municipality
Targeted Labour	4.10	Add the following: “Targeted Labour” means: Unemployed persons who are employed as local labour on the project. The Contractor shall endeavour to employ 40% women; 20% youth who are between 18 and 35 and 1% people with disabilities.
Year end break	5.8.1	If applicable during the duration of the construction period – the period around the 15 th December and the first Monday of the subsequent year.
Contract Guarantee	6.2	Within 14 days of Letter of Appointment – at time of Site Handover. Add the following to the Clause: “The contract may be awarded to a Subsidiary Company on the condition that the Holding Company shall in addition to the

Municipality 1		Municipality 2		Contractor	
----------------	--	----------------	--	------------	--

		Surety specified, assume responsibility for the due and proper performance of the Works and the fulfillment of the contract, should the Subsidiary Company be unable to do so.”
Guarantee Sum	6.2	10 % of total contract amount excluding Contingencies, VAT for the full construction period.
Commencement of Works	5.3	<p>Within 14 days of Commencement Date</p> <p>On the commencement of Work (Site Handover) the Engineer shall deliver to the contractor 3 copies of the drawings. One copy of the signed contract document will be prepared after signing of the contract and delivered to the contractor to be kept on site at all times and be available to the Engineer or any person authorized by him.</p> <p>Additional copies of Drawings and Contract document will be for the cost of the Contractor.</p> <p>The Contractor shall, in accordance with the Engineer's instructions, maintain a register on the site of all Drawings and revisions thereof in the chronological order in which they are delivered to him.</p> <p>Add to the Clause Commencement of Work will only take place once the following documentation were submitted to the office of the Consulting Engineer:</p> <ul style="list-style-type: none"> ▪ Letter of Acceptance ▪ Construction/Performance Guarantee ▪ Health & Safety File ▪ Letter of Appointment of OHS Rep or Officer ▪ Letter of Good Standing Workman's Compensation ▪ Prove of submission of Registration of Project at Department of Labour <p>The Engineer shall establish the basic reference pegs and benchmarks on the Site and give to the Contractor the particular thereof in sufficient time to enable the Contractor to meet his approved programme</p> <p>After compliance by the Engineer with the provisions of Sub-Clause 5.3, the Contractor shall be responsible for the true and proper setting out of the Works and for the correctness of the position, levels, dimensions and alignment of all parts of the Works and for the provision of all necessary instruments, appliances and labour in connection therewith.</p>

Municipality 1		Municipality 2		Contractor	
----------------	--	----------------	--	------------	--

		<p>If at any time during the progress of the Works, any error shall appear or arise in the position, levels, dimensions or alignment of any part of the Works, the Contractor, on being required to do so by the Engineer, shall at his own expense rectify such error to the satisfaction of the Engineer, but if such error is based on incorrect data supplied in writing by the Engineer or if there is any delay in providing the particulars required in terms of Sub-Clause 5.3, the Contractor shall, in respect of that delay and the cost of such rectification.</p> <p>The Contractor shall carefully protect and preserve all benchmarks, sight-rails, pegs and beacons used in setting out the Works.</p> <p>The checking of any setting- or of any line or level by the Engineer shall not relieve the contractor of his responsibility for the correctness thereof.</p> <p>If active construction has not started within 14 days of site handover the Client, Mogale City Local Municipality reserves the right in terms of Clause 9.2.1.3.2 to terminate the contract and MCLM shall not be held liable for any loss or damages resulting from such a termination</p>
Sub Contractor	4.4	<p>Add the following to clause 4.4</p> <p>If a Sub-contractor's obligations extend beyond the Defects liability period and the Engineer, prior to this date, instructs the Contractor to assign the benefit of such obligations to the Employer, then the Contractor shall do so. Unless otherwise stated in the assignment, the Contractor shall have no liability to the Employer for the work carried out by the Sub-contractor after the assignment takes effect.</p>
Access to the Site	5.4	<p>Site Handover Certificate to be given at Time of Site Handover.</p> <p>Add the following:</p> <p>The Contractor shall as far as possible, confine his operations to the limits of the areas made available to him by the Engineer, but if the land is insufficient for the needs of the work, the Contractor shall make his own arrangements with the owners or tenants concerned for whatever additional land he may require and pay all rent and other charges in connection therewith. The Contractor shall be responsible for all damages and shall indemnify the Employer against all claims which may arise.</p> <p>Add to the clause:</p>

Municipality 1		Municipality 2		Contractor	
----------------	--	----------------	--	------------	--

		The Engineer shall establish the basic reference pegs and benchmarks on the Site and give to the Contractor the particulars thereof in sufficient time to enable the Contractor to meet his approved programme.
Contractor's Obligations	4	<p>Add to the clause: "All costs in complying with the provisions of complying with Clauses 4.8; 4.9; 4.10 and 4.11 shall be allowed for in the rates tendered"</p> <p>Add the following to this sub-clause:</p> <p>"The Contractor shall conduct tests or have them conducted continually on a regular basis, to check the properties of natural materials and processed natural materials and of products manufactured on site, such as aggregate or asphalt. Although not a requirement for the contractor to conduct regular tests on any commercially produced products such as cement, bitumen, steel and pipes, the Contractor shall remain fully responsible for any defective material or equipment provided by him.</p> <p>Similarly, the quality of all elements of the works shall be checked on a regular basis so as to ensure compliance with the specified requirements.</p> <p>The intensity of control and of tests to be conducted by the Contractor in terms of these obligations is not specified but shall be adequate to ensure that proper control is being exercised to the satisfaction of the Engineer.</p> <p>Where any natural materials or products made from natural materials are supplied, upon completion of each element of the construction works, the contractor shall test and check such materials, products and or elements for compliance with the specified requirements and shall submit his results to the Engineer for approval. Such submission shall include all his measurements and test results and shall furnish adequate compliance with the specified requirements."</p>
Programme of Works	5.6	<p>At time of Site Handover</p> <p>Add the following sub-clause: Should the Contractor fail to comply with his obligations in terms of Sub-Clause 5.6, the Employer shall be entitled to withhold 25% of monies due to the contractor, until such time as satisfactory programme has been submitted for approval.</p>

Municipality 1		Municipality 2		Contractor	
----------------	--	----------------	--	------------	--

Patent Rights	4.6	The following Subclause is added to Clause 4.6: “The copyright in all documents, drawings and records related to the purpose and scope of the Works or related in any other manner to the Works, shall vest in the Employer and the Contractor shall not furnish any information in connection with the Works to anybody without the approval of the Employer.”
Contractor’s Employees	4.10 4.10	Add the following to Clause: The Contractor is to utilize local labour where possible. (Refer to Contract Data and Project Specifications) Add the following The Contractor is responsible for the behaviour and performance of his own and his Sub-contractor’s personnel and shall at his own cost, for the duration of the contract and maintenance period of Wor333ks, make the necessary arrangements to prevent unlawful or inappropriate behaviour, and shall indemnify the Employer and the Engineer against any claims in connection with non-compliance with the act, for any loss or injury, or any other claim, for any action or neglect to act on the part of the Contractor’s or his Sub-contractor’s personnel.
Contractor’s superintendence	4.12	Add the following new clause The Contractor or his representative shall attend all site meetings with the Employer and / or Engineer on the dates as nominated by the Engineer. The purpose of the meetings shall be to evaluate the progress of work and to discuss the matters relevant to the contract as required by the parties concerned. Unless specifically invited by the Engineer, the Sub-contractors of the Contractor may not attend these site meetings.
Expected risks	8.3	Add the following: “Risk arising from political riot and malicious damage, unless these risks are insurable with the South African Special Insurance Association at the time of tendering and it is stipulated in the Contract Data that the contractor is to effect insurance against these risks.”
Indemnifications	8.4	“hereby indemnifies the Employer, the Engineer and all consultants against any liability in respect of damage to or physical loss of the property of any person, including any employee of the Contractor, or injury to or death of any person, including any employee of the Contractor and”

Municipality 1		Municipality 2		Contractor	
----------------	--	----------------	--	------------	--

		<p>Add the following:</p> <p>Without prejudice to any of the rights of the Employer arising from any of the provisions of this agreement, the Contractor indemnifies and holds the Employer harmless against all loss, liability, damage, claim, proceeding or expenses of any nature whatever (including without limiting the generality of the foregoing) all party, attorney and client costs incurred by the Employer which the Employer may suffer as a result of or which may be attributed to:</p> <ul style="list-style-type: none"> -any liability of the Contractor, whether actual or contingent; -any liability of the Contractor for taxation, for which purpose the terms "taxation" shall include normal taxation, value added tax, minimum or secondary taxation on companies, District or equivalent levies, all other forms of levies or taxation and any penalties or interest as a result thereof; -the contractors performance in terms of this agreement; -The Contractor indemnifies the Employer in respect of all actions, prosecutions or claims of any nature that might be brought in any manner against the Contractor as a consequence of the negligence of the Contractor, its employees, members or any persons under its control; <p>The Contractor shall not be liable for such liability, loss, damage, claim, proceeding or expense where same was due to any act or neglect of the Employer or any person for whose actions the Employer is legally liable.</p>
Insurances	8.6	Special consideration should be given to damage to existing infrastructure.
Limit of indemnity	8.6.1.3	R2 000 000 per claim, claims unlimited
Other Insurances	8.6.1.2	Special Risk Insurance – SASRIA (coupon to be provided)
Workmen's Compensation	4.3	The Contractor shall also provide proof, that he has paid all contributions required in terms of the provisions of the Act.
Amendments to Schedule of Quantities	6.3	The extent of the Works that will be included under this contract will be determined by the availability of funds. Should the tender amounts exceed the available funds, the amounts will be adjusted and the extent of the works decreased. It is

Municipality 1		Municipality 2		Contractor	
----------------	--	----------------	--	------------	--

		<p>therefore emphasized that the tendered unit rates must be realistic and will not be affected should the quantities be adjusted. The rates under “Preliminary and General” will be adjusted proportionally with respect to tender and contract amounts. The tendered unit rates will remain applicable.</p> <p>The right to adjust the extent of the contract is, therefore, reserved by the Employer, but approval will be sought from the successful Tenderer before the contract is awarded.</p>
Variations	6.4	<p>The cost of any Variations ordered in writing by the Engineer and the applicable rates must be accepted by the Engineer in writing prior to execution, in order to be accepted. Special reference will be given to the tendered rates and the wide interpretation of the term “similar conditions” in determining rates.</p> <p>Add the following:</p> <p>The quantities in the Bill of Quantities are nominal quantities which are included solely for the purpose of Tender evaluation. These quantities are not guaranteed, nor have they any other significance in terms of the contract other than a means of assessing the Tender.</p> <p>Only the actual quantities of work, which are executed by the Contractor in fulfillment of his obligations under the Contract, will be measured or approved by the Engineer for payment purposes.</p> <p>An alteration of the quantities included in the Bill of Quantities shall not affect the validity of the contract. The Tendered rates and prices shall remain valid and applicable irrespective of any differences between the quantities in the Bill of Quantities and the quantities finally certified for payment.</p>
Provisional sums and prime cost sums	6.6	<p>Delete <i>this sub-clause and replaced with the following:</i></p> <p>“Expenditure in connection with Provisional and Prime Cost Sums shall be solely at the discretion and on the instruction of the Engineer. No expenditure shall be incurred under a Contingency Allowance without the written approval of the Employer. Any parts of the amounts provided under any of the above items in the bill of Quantities which are not expended shall not be included in the Contract Price.</p>

Municipality 1		Municipality 2		Contractor	
----------------	--	----------------	--	------------	--

Daywork percentages	6.5.1.1	As tendered in Schedule of Quantities
Special non-working days	5.8.1	The period 16 December to 5 January inclusive, plus Good Friday, Human Rights Day, Freedom Day, Workers Day and Youth Day
Extension of time for completion	5.12	<p>In general, extension of time for the completion of Works will, in terms of the General conditions of Contract, be granted only for additional work and for circumstances which could not have been foreseen, and are beyond the control of the Contractor.</p> <p>No extension of time for completion will be granted on account of normal inclement weather, but extension of time shall be determined for abnormal rainfall or wet conditions in accordance with the formula given below, separately for each calendar month or part thereof. It shall be calculated for the full period for the completion of the Contract including any extension thereof by the formula:</p> $V = (Nw - Nn) + \frac{(Rw - Rn)}{X}$ <p>The symbols shall have the following meanings:</p> <p><i>V</i> = Extension of time in calendar days in respect of the calendar month under consideration</p> <p><i>Nw</i> = Actual number of days during the calendar month on which a rainfall of Ymm or more has been recorded.</p> <p><i>Nn</i> = Average number of days, as derived from existing rainfall records provided in the table below on which a rainfall of Ymm or more has been recorded for the calendar month</p> <p><i>Rn</i> = Average rainfall in mm for the calendar month, as derived from the rainfall records supplied in the table below.</p> <p><i>Rw</i> = Actual rainfall in mm for the calendar month under consideration.</p> <p><i>X</i> = 10</p> <p><i>Y</i> = 10</p> <p>If <i>V</i> is negative and its absolute value exceeds <i>Nn</i>, then <i>V</i> shall be taken as equal to minus <i>Nn</i>.</p> <p>The total extension of time shall be the algebraic sum of the monthly totals for the period of construction, but if the grand total is negative the time for completion shall not be reduced due to abnormal low rainfall. Extensions of time for part of a month shall be calculated using pro rata values of <i>Nn</i> and <i>Rn</i>.</p>

Municipality 1		Municipality 2		Contractor	
----------------	--	----------------	--	------------	--

		<p>The factor $(Nw - Nn)$ shall be considered to represent a fair allowance for variations from the average number of days during which rainfall exceeds Ymm.</p> <p>The factor $\frac{Rw - Rn}{x}$ shall be considered to represent a fair allowance for variations from the average in the number of days during which rainfall had not exceeded Ymm, but wet conditions had prevented or had disrupted work. The formula does not take into account flood damage which could cause further or concurrent delays, and which should be treated separately as far as extension of time is concerned.</p> <p>Accurate rain gauging shall be taken at a suitable point on Site. This information shall be regarded as the actual rainfall for this contract. The readings will be done by the Engineer and the Contractor may attend this readings and shall at his own expense take all necessary precautions to ensure that the rain gauge cannot be interfered with by unauthorized persons.</p>
Time for Completion	5.14	As per tender and approved by MCLM
Penalty for Delay	5.13	<p>To a maximum of R2500-00 per calendar day</p> <p>Add the following: With the proviso that the amount of the penalty for delay shall at no time be reduced to an amount less than the actual cost of supervising and administering the Contract during such delay”</p>
Contract Price Adjustment	6.8.2	<p>The following values for the different factors are to be used as per SAFCEC guidelines:</p> <p>$x = 0,10$ <i>(New Road construction – Urban Roads (a) Including Bitumen)</i> aLt (Labour) = 0,25 bPt (Plant) = 0,15 cMt (Material) = 0,55 dFt (Fuel) = 0,05</p> <p>The different values for the calculation of the price adjustment factor shall be for the Gauteng Province and the Diesel index shall be for the Witwatersrand Area</p> <p>The coefficient for fuel may need to be revised from time to time, as it has a tendency to increase out of proportion to the other factors in the CPA formula</p>
Special Materials	6.8.3	As per Schedule of Special Materials

Municipality 1		Municipality 2		Contractor	
----------------	--	----------------	--	------------	--

Claims Procedure	6.10.4	A strict interpretation is given to the time limits and procedures given in these clauses and any claim, which does not strictly comply with these requirements, will not be considered.
Materials on Site	6.10.1.5	80% (Delivery Notes and Tax Invoices to be provided)
Retention Money	6.10.3	No interest will be paid on retention money
Retention Guarantee	6.10.3	A Retention Guarantee is not acceptable Add to the clause: 10% Retention will be deducted from each payment certificate. Retention will be reduced to 5% once Practical Completion Certificate is issued for the work.
Defects Liability Period	6.14.5.2	12 Months
Dispute Resolution	10	Adjudication, Arbitration and the Court will be acceptable dispute resolution mechanisms
Cancellation of Contract	9.1	In addition if the contractor fails to adequately protect the existing works / infrastructure against damage and thereby unduly endanger the Works – the employer may cancel the contract and recover damages and losses.
Community Liaison Officer (CLO).	4.10 4.8.1.2	A CLO to be appointed as required.
Labour costs	4.3	The minimum statutory labour rates as set by Government (See SAFCEC website for details) and or the Department of Labour for the area where the site is located must be adhered to by the contractor and must be adjusted as and when required by law. It is the Tenderer's responsibility to verify the latest labour rates and any anticipated cost increases.
Quality of materials and workmanship	7.2	Add to the Clause: "The source of supply of all materials including all stone, sand, gravel or soil or any other natural material required in the execution of the Works shall be located by the Contractor. No material shall be used until it has been approved by the Engineer. "
Information in respect of plant	7.1	Add to Sub-Clause 7.1.1 (a) Details in writing of all Constructional Plant and Temporary Works which is brought onto site by, or on

Municipality 1		Municipality 2		Contractor	
----------------	--	----------------	--	------------	--

		<p>behalf of, the Contractor for the purpose of the Works, and which is hired, leased or the subject of hire-purchase agreements, together with the names of the hirers, lessors or owners thereof, shall be supplied to the Engineer by the Contractor.</p> <p>(a) The Employer may, in order to avoid seizure by the hirer, owner or lessor, at the Employer's option, pay to such hirer, owner or lessor the amount of any overdue installment, or any other sum payable under the agreement for hire, lease or hire purchase, and, in the event of so doing, any amount so paid by the Employer shall be a debt due from the Contractor to the Employer, and may be deducted by the Employer from any money due, or that may become due, to the Contractor in terms of the Contract, or may be recovered by the Employer from the Contractor by law.</p> <p>(c) Possession of all Constructional Plant and Temporary works provided by Sub-Contractors shall be deemed to vest in the Employer immediately the same is brought onto site, and shall mutatis mutandis be subject to the provisions of the Clause hereinbefore contained. The Contractor shall ensure that the foregoing provision will be inserted in all sub-contractors.</p>
Vesting of Materials	6.9	<p>Add to Sub-Clause 6.9.1.2</p> <p>"The Contractor shall where practicable before delivery and, in any event not later than 24 hours after delivery to the site, inform the Engineer of any materials which are not his sole property."</p>
Valuation of material brought onto site	6.9	<p>Add to Clause 6.10.1.5</p> <p>""In order to preclude seizure by the owner of any construction equipment being held by the Contractor on a hire-purchase agreement for the purposes of the contract, the Employer shall be entitled to pay any such owner the amount of any outstanding installment or other sum owing under any hire or hire-purchase agreement and in the event of his doing so, any amount thus paid by him shall be a debt payable to the Employer by the contractor and may be deducted by the Employer from any monies owing or that may become owing the contractor in terms of the Contract, or be recovered at law from the Contractor by the Employer.</p> <p>When entering into any subcontract for the execution of any part of the works, the Contractor shall incorporate in such subcontract, by reference or otherwise, the provisions of this</p>

Municipality 1		Municipality 2		Contractor	
----------------	--	----------------	--	------------	--

		clause in respect of construction equipment brought to the site by the subcontractor.”
Defects liability period	5.14.5.2 6.10.5.1	Add to Sub-Clause 5.14.5.2 “In the event of the Contractor not completing all the outstanding work within the period specified by the Engineer in terms of Clause 7.8, the Engineer shall have the right to extend the Period of Maintenance by the additional time taken by the Contractor to complete such outstanding work to the satisfaction of the Engineer. The full retention applicable to the Period of Maintenance shall apply to such extension.”
Contract price Adjustment Schedule	Clause 1	Add the following: “The rate or price stated in the Contract by the Contractor for a “special material” shall exclude VAT but include all other obligatory taxes and levies.” <i>“ The special materials are listed in Part T2: Returnable Documents to be completed by the Tenderer.”</i>
Contractor’s Superintendence	4.12	Add the following additional Clause 4.12.2 “The Tenderer is to fill in the names of the site agent and foreman in the space provided in Schedule E1.”
Schedule of Quantities – Estimated quantities	6.7	Tenderer to note that all quantities supplied in Schedule of Quantities are estimated quantities and all items will be re-measured on site. Add to the clause: “An allowance equal to 100% of the task rate or daily rate shall be paid by the contractor to workers who attend formal training.”
Completion, Approval Certificates and Defects Liability Period	5.14	Add the following to this Clause: “... and a land surveyor’s certificate has been submitted certifying the presence and correctness of all erf and boundary pegs, where applicable.” Add the following: However, a Certificate of Completion will not be issued before the contractor hands over a consolidated Health and Safety file that shall include all the specified information.
Cession Subcontractors and Material Suppliers	4.4	Add the following to this clause

Municipality 1		Municipality 2		Contractor	
----------------	--	----------------	--	------------	--

		<p>The Employer may, in order to avoid seizure by the owner, material supplier, subcontractor, at the Employer's option, pay to such owner, material supplier, subcontractor, the amount of any overdue installment, or any other sum payable under the agreement for purchase or services, and, in the event of so doing, any amount so paid by the Employer shall be a debt due from the Contractor to the Employer, and may be deducted by the Employer from any money due, or that may become due, to the Contractor in terms of the Contract, or may be recovered by the Employer from the Contractor by law.</p> <p>The Retention money due to the Contractor will not be payable to the contractor until all works are completed as per GCC 2015 and will only be paid to the Contractor once all cession suppliers and subcontractors and any other payments due has been paid in full,</p>
--	--	-----------------------------------------------------------------------------------------------------------------------------------------------------------------------------------------------------------------------------------------------------------------------------------------------------------------------------------------------------------------------------------------------------------------------------------------------------------------------------------------------------------------------------------------------------------------------------------------------------------------------------------------------------------------------------------------------------------------------------------------------------------------------------------------------------------------------------------------------------------------------------------------------------

TABLE 1 : EXPECTED NUMBER OF WORKING DAYS LOST PER MONTH DUE TO NORMAL RAINFALL

(The Engineer reserves the right to update Table 1 with the latest data from the Weather Bureau from a weather station close to the Site of Works)

Month	Expected number of working days lost as result of normal rainfall	Average monthly rainfall (mm)
January	4	111.3
February	4	122.9
March	3	70.8
April	1	28.3
May	1	23.4
June	0	5.6
July	0	0.2
August	0	2.1
September	1	18.5
October	2	48.7
November	3	100.98
December	5	122.10
Total	24 days	654.9 mm

Municipality 1		Municipality 2		Contractor	
----------------	--	----------------	--	------------	--

C1.4 PRO-FORMA PERFORMANCGUARANTEE

For use with the General Condition of Contract for Construction Works, Second Edition, 2015.

GUARANTEE DETAILS AND DEFINITIONS

“Guarantor” means:

Physical address:

“Employer” means: MOGALE CITY LOCAL MUNICIPALITY

“Contractor” means:

“Engineer means. ANDRE BOTES

“Works” means:

“Site” means:

“Contract means: The Agreement made in terms of the Form of Offer and Acceptance and such amendments or additions to the Contract as may be agreed in writing between the parties.

“Contract Sum” means: The accepted amount inclusive of tax of R.....

Amount in words:

“Guaranteed Sum” means: The maximum aggregate amount of R.....

Amount in words:

“Expiry Date” means:

CONTRACT DETAILS

Engineer issues: Interim Payment Certificates, Final Payment Certificate and the Certificate Completion of the Works as defined in the Contract.

PERFORMANCE GUARANTEE

1. The Guarantor’s liability shall be limited to the amount of the Guaranteed Sum.
2. The Guarantor’s period of liability shall be from and including the date of issue of this Performance Guarantee and up to and including the Expiry Date or the Date of issue by the Engineer of the Certificate of Completion of the Works or the date of payment in full of the Guaranteed Sum, whichever occurs first. The Engineer and/or the Employer shall advise the Guarantor in writing of the date on which the Certificate of Completion of the Works has been issued.
3. The Guarantor hereby acknowledges that:
 - 3.1 any reference in this Performance Guarantee to the Contract is made for the purpose of convenience and shall not be construed as any intention whatsoever to create an accessory obligation or any intention whatsoever to create a Suretyship;
 - 3.2 its obligation under this Performance Guarantee is restricted to the payment of money.
4. Subject to the Guarantor’s maximum liability referred to in 1, the Guarantor hereby undertakes to pay the Employer the sum certified upon receipt of the documents identified in 4.1 to 4.3:

- 4.1 A copy of a first written demand issued by the Employer to the Contractor stating that payment of a sum certified by the Engineer in an Interim or Final Payment Certificate has not been made in terms of the Contract and failing such payment within seven (7) calendar days, the Employer intends to call upon the Guarantor to make payment in terms of 4.2;
 - 4.2 A first written demand issued by the Employer to the Guarantor's physical address with a copy to the Contractor stating that a period of seven (7) days has elapsed since the first written demand in terms of 4.1 and the sum certified has still not been paid;
 - 4.3 A copy of the aforesaid payment certificate which entitles the Employer to receive payment in terms of the Contract of the sum certified in 4.
5. Subject to the Guarantor's maximum liability referred to in 1, the Guarantor undertakes to pay to the Employer the Guaranteed Sum or the full outstanding balance upon receipt of a first written demand from the Employer to the Guarantor at the Guarantor's physical address calling up this Performance Guarantee, such demand stating that:
 - 5.1 the Contract has been terminated due to the Contractor's default and that this Performance Guarantee is called up in terms of 5; or
 - 5.2 a provisional or final sequestration or liquidation court order has been granted against the Contractor and that the Performance Guarantee is called up in terms of 5; and
 - 5.3 the aforesaid written demand is accompanied by a copy of the notice of termination and/or the provisional/final sequestration and/or the provisional liquidation court order.
 6. It is recorded that the aggregate amount of payments required to be made by the Guarantor in terms of 4 and 5 shall not exceed the Guarantor's maximum liability in terms of 1.
 7. Where the Guarantor has made payment in terms of 5, the Employer shall upon the date of issue of the Final Payment Certificate submit an expense account to the Guarantor showing how all monies received in terms of this Performance Guarantee have been expended and shall refund this Guarantor any resulting surplus. All monies refunded to the Guarantor in terms of this Performance Guarantee shall interest at the prime overdraft of the Employer's bank compounded monthly calculated from the date payment was made by the Guarantor to the Employer until the date of refund.
 8. Payment by the Guarantor in terms of 4 or 5 shall be made within seven (7) calendar days upon receipt of the first demand to the Guarantor.
 9. Payment by the Guarantor in terms of 5 will only be made against the return of the original Performance Guarantee by the Employer.
 10. The Employer shall have the absolute right to arrange his affairs with the Contractor in any manner which the Employer may deem fit and the Guarantor shall not have the right to claim his release from the Performance Guarantee on account of any conduct alleged to be prejudicial to the Guarantor.

Municipality 1		Municipality 2		Contractor	
----------------	--	----------------	--	------------	--

11. The Guarantor chooses the physical address as stated above for the service of all notices for all purposes in the connection herewith.

12. This performance Guarantee is neither negotiable nor transferable and shall expire in terms of 2, where after no claims will be considered by the Guarantor. The original of this Guarantee shall be returned to the Guarantor after it has expired.

13. This Performance Guarantee, with the required demand notices in terms of 4 or 5, shall be regarded as a liquid document for the purposes of obtaining a court order.

14. Where this Performance Guarantee is issued in the republic of South Africa the Guarantor hereby consents in terms of Section 45 of the Magistrate's Courts Act no 32 of 1944, as amended, to the jurisdiction of the Magistrate's court of any district having jurisdiction in terms of Section 28 of the said Act, notwithstanding that the amount of the claim may exceed the jurisdiction of the Magistrate's Court.

15. Our total liability hereunder shall not exceed the sum of _____
 _____ (R_____).

16. We hereby choose domicilium citandi et executandi for all purposes arising hereof at

IN WITNESS WHEREOF this guarantee has been executed by us at _____ on this
 _____ day of _____ 20_____.

Signed at: Date:

Guarantor's Signatory (1):

Capacity:

Guarantor's Signatory (2):

Municipality 1		Municipality 2		Contractor	
----------------	--	----------------	--	------------	--

AGREEMENT IN TERMS OF THE OCCUPATIONAL HEALTH AND SAFETY ACT 1993, SECTION 37(2)

Gauteng Provincial Government, Mogale City LM and the Contractor hereby agree, in terms of the provisions of Section 37(2) of the Occupational Health and Safety Act 1993 (Act 85 of 1992, hereinafter referred to as the Act), that the following arrangements and procedures shall apply between them to ensure compliance by the Contractor with the provisions of the Act, namely:

- (a) The Contractor undertakes to acquaint the appropriate officials and employees of the Contractor with all the relevant provisions of the Act and the regulations promulgated in terms of the Act and Gauteng Provincial Government, Mogale City LM Safety Precautions and Health and Safety Instructions included in the contract documents.
- (b) The Contractor undertakes that all relevant duties, obligations and prohibitions imposed in terms of the Act and Regulations and Gauteng Provincial Government, Mogale City LM safety Precautions and Health and Safety Instructions included in the contract documents will be fully complied with.
- (c) In relation to any work or activity performed by the Contractor, his workmen or any other person for whose acts or omissions the Contractor is responsible in terms of the Contract, the Contractor hereby accepts sole liability for such due compliance with the relevant duties, obligations and prohibitions imposed by the Act and Regulations and expressly absolves Gauteng Provincial Government, Mogale City LM from itself being obliged to comply with any of the foresaid duties, obligations and prohibitions.
- (d) The Contractor agrees that any duly authorised officials of the council shall be entitled, although not obliged, to take such steps as may be necessary to ensure that the Contractor has complied with his undertakings as set out more fully in paragraphs (a) and (b) above, which steps may include, but will not be limited to, the right to inspect any appropriate site or premises occupied by the Contractor, or to inspect any appropriate records held by the Contractor.
- (e) The Contractor shall be obliged to report forthwith in writing to the Engineer/Architect full details of any investigation, complaint or criminal charge which may arise as a consequence of the provisions of the Act and Regulations, pursuant to work performed in terms of this Contract.

The Employer and Contractor hereby agree, in terms of the provisions of Section 37(2) of the Occupational Health and Safety Act No.85 of 1993, hereinafter referred to as “the Act”, that the contractor as an employer in its own right and in its capacity as contractor for the execution of the works, shall have certain obligations and that the following arrangement shall apply between them to ensure compliance by the contractor with provisions of the Act, namely:

- a) The contractor undertakes to acquaint the appropriate officials and the employees of the contractor with all relevant provisions of the Act, and the regulation promulgated in terms of the Act, and
- b) The contractor undertakes that all relevant duties, obligations and prohibitions imposed in terms of the Act and regulations will be fully complied with, and
- c) The contractor hereby accepts sole responsibility for such due compliance with the relevant duties, obligations and prohibitions imposed by the Act and regulations and expressly absolves the employer and the employer’s consulting engineers from being obliged to comply with any of the aforesaid duties, obligations and prohibitions in respect of the work included in the contract.

Municipality 1		Municipality 2		Contractor	
----------------	--	----------------	--	------------	--

- d) The contractor shall be obliged to report forthwith to the employer any investigation, complaint or criminal charge which may arise as a consequence of the provisions of the Act and regulations pursuant to work performed on behalf of the employer, and shall, on written demand, provide full details in writing of such investigation, complaint or criminal charges.
- e) The Employer recognizes the right of each employee to work safely in a healthy environment under decent human conditions. Each employee has the right to return home safely and healthy to his home and family after each day's work.
- f) Work should not be done at the expense of human safety or health.
- g) Work shall be executed under humane conditions, especially with reference to hours and H&S issues in mind.
- h) The PC shall appoint a fulltime H&S Manager should he have more than 50 employees on site. A fulltime Safety Representative shall be present on site for 50 employees or less

ON BEHALF OF MOGALE CITY MUNICIPALITY

DATE

WITNESSES 1. _____

2. _____

FOR THE CONTRACTOR _____

DATE: _____

WITNESSES 1. _____

2. _____

Municipality 1		Municipality 2		Contractor	
----------------	--	----------------	--	------------	--

OCCUPATIONAL HEALTH AND SAFETY ACT, 1993
Regulation 3 of the Construction Regulations, 2003

NOTIFICATION OF CONSTRUCTION WORK

1.(a) Name and postal address of principal contractor:

(b) Name and tel. no of principal contractor's contact person:

(c) Principal contractor's compensation registration number: _____

3.(a) Name and postal address of client:

(b) Name and tel no of client's contact person or agent:

4.(a) Name and postal address of designer(s) for the project:

(b) Name and tel. no of designer(s) contact person:

5 (a) Name and telephone number of principal contractor's construction supervisor on site appointed in terms of regulation 6.(1).

(b) Name/s of principal contractor's sub-ordinate supervisors on site appointed in terms of regulation 6.(2).

6 Exact physical address of the construction site or site office:

7 Nature of the construction work:

9. Expected commencement date: _____

Municipality 1		Municipality 2		Contractor	
----------------	--	----------------	--	------------	--

- 10. Expected completion date: _____
- 11. Estimated maximum number of persons on the construction site. _____
- 12. Planned number of contractors on the construction site accountable to principal contractor:

- 13. Name(s) of contractors already chosen.

Principal Contractor

Date

Client

Date

THIS DOCUMENT IS TO BE FORWARDED TO THE OFFICE OF THE DEPARTMENT OF LABOUR **PRIOR TO COMMENCEMENT** OF WORK ON SITE.

ALL PRINCIPAL CONTRACTORS THAT QUALIFY TO NOTIFY MUST DO SO EVEN IF ANOTHER PRINCIPAL CONTRACTOR ON THE SAME SITE HAD DONE SO PRIOR TO THE COMMENCEMENT OF WORK

Municipality 1		Municipality 2		Contractor	
----------------	--	----------------	--	------------	--

**AGREEMENT TO ACCEPT THE CONDITIONS OF THE ENVIRONMENTAL MANAGEMENT PLAN
PERTAINING TO THIS PROJECT**

Whereas _____ (the Contractor)

*Company Registration No. _____

Address: _____

a * Company incorporated with limited liability according to the company laws of the Republic of South Africa, *Partnership, *Close Corporation, * Public Company (hereinafter called the contractor), represented herein by _____ in his capacity as _____ duly authorised hereto by a articles of association, resolution, power of attorney, or otherwise as duly signed and declared in Form F.2 of this document.

Do hereby agree that the following arrangements and procedures shall apply to the abovementioned Contractor to ensure compliance with the provisions of the Environmental Management Plan (EMP), namely:

- (a) The Contractor undertakes to acquaint the appropriate officials and employees of the Contractor with all the relevant provisions of the EMP, the regulations and conditions in terms of the EMP.
- (b) The Contractor undertakes that all relevant duties, obligations and prohibitions imposed in terms of the EMP and the instructions of the duly authorised Environmental Officer, enforcing the conditions of the EMP, will be fully complied with.
- (c) In relation to any work or activity performed by the Contractor, his workmen or any other person for whose acts or omissions the Contractor is responsible in terms of the Contract, the Contractor hereby accepts sole liability for such due compliance with the relevant duties, obligations and prohibitions imposed by the EMP and expressly absolves the Dept of Housing from itself being obliged to comply with any of the foresaid duties, obligations and prohibitions.
- (d) The Contractor shall be obliged to report forthwith in writing to the Engineer full Details of any investigation, complaint or criminal charge which may arise as a consequence of the provisions of the EMP, pursuant to work performed in terms of this Contract.

FOR THE CONTRACTOR _____

DATE: _____

WITNESSES 1. _____

2. _____

Municipality 1		Municipality 2		Contractor	
----------------	--	----------------	--	------------	--

BOND FOR MATERIAL ON SITE

CONTRACT NO : _____

EMPLOYER : _____

CONTRACTOR : _____

DESCRIPTION OF CONTRACT : _____

I/We, the undersigned, _____ **(Bank or Insurance Company)**
do hereby bind ourselves as surety and co-principal debtors in solidum for compensating the Employer where the ownership of material for some reason or other cannot pass to the Employer, or the Employer by law is expected to pay a third party to obtain ownership of material in spite of the fact that the Employer paid the Contractor as per clause 62(1)(b) of the general conditions of contract, and for all losses, damages, and expenses that may be suffered or incurred by the Employer as a result of payment for material on site, renouncing all benefits from the legal exceptions ordinis seu excussionis et divisionis "no value received" and all other exceptions which might or could be pleaded against the validity of this guarantee, with the meaning and effect of which exceptions we declare ourselves to be fully acquainted; provided that the liability of the undersigned under this guarantee is limited to (specify amount of bond)

_____ (R_____) and will
lapse on the issue of the completion certificate in terms of the Contract, unless the surety is advised in writing by the Employer before issue of the said certificate of his intention to institute claims and the particulars thereof, in which event this guarantee shall remain in force until all such claims are paid or settled.

FOR AND ON BEHALF OF _____ **(Surety)**

AT _____ on this _____ day of _____ 20_____.

CAPACITY

FULL ADDRESS : _____

AS WITNESSES :

1. _____

2. _____

**Delete whichever is inapplicable*

Municipality 1		Municipality 2		Contractor	
----------------	--	----------------	--	------------	--

BOND FOR MATERIAL NOT ON SITE

CONTRACT NO : _____

EMPLOYER : _____

CONTRACTOR : _____

DESCRIPTION OF CONTRACT : _____

I/We, the undersigned, _____ (Bank or Insurance Company) do hereby bind ourselves as surety and co-principal debtors in solidum for compensating the Employer where the ownership of material for some reason or other cannot pass to the Employer, or the Employer by law is expected to pay a third party to obtain ownership of material in spite of the fact that the Employer paid the Contractor as per clause 62(1)(b) of the general conditions of contract, and for all losses, damages and expenses that may be suffered or incurred by the Employer as a result of payment for material prior to delivery on site, renouncing all benefits from legal exceptions ordinis seu excussionis et divisionis "no value received" and all other exceptions which might or could be pleaded against the validity of this guarantee, with the meaning and effect of which exceptions we declare ourselves to be fully acquainted; provided that the liability of the undersigned under this guarantee is limited to (specify amount of bond)

_____ (R_____) and will lapse on the issue of the completion certificate in terms of the contract, unless the surety is advised in writing by the Employer before issue of the said certificate of his intention to institute claims and the particulars thereof, in which event this guarantee shall remain in force until all such claims are paid or settled.

FOR AND ON BEHALF OF _____ **(Surety)**

AT _____ on this _____ day of _____ 20_____.

CAPACITY

FULL ADDRESS : _____

AS WITNESSES :

1. _____

2. _____

** Delete whichever is not applicable*

Municipality 1		Municipality 2		Contractor	
----------------	--	----------------	--	------------	--

OWNERSHIP OF MATERIALS

CONTRACT NO : _____

EMPLOYER : _____

CONTRACTOR : _____

DESCRIPTION OF CONTRACT : _____

In order to facilitate payment for material on site in terms of clause 37.1 of the general conditions of contract, it is hereby confirmed that, although materials may have been supplied on credit to the above named Contractor, ownership of such materials, when delivered will vest with the Contractor.

In the event therefore of such materials being delivered on site or any authorised extended site, ownership thereof will then vest with the Employer in terms of clause 35.1 of the said general conditions of contract.

SIGNED ON BEHALF OF _____ **(Supplier)**

AT _____ on this _____ day of _____ 20_____.

CAPACITY

FULL ADDRESS : _____

AS WITNESSES :

1. _____

2. _____

SIGNATURE

Signatories for companies must establish their authority by attaching a copy of the relevant resolution of the board of directors, duly signed and dated, to this form.

PART C2 : PRICING DATA

Municipality 1		Municipality 2		Contractor	
----------------	--	----------------	--	------------	--



CONSTRUCTION OF SURFACE SEALS, ASPHALT BASE AND SURFACINGS ON AN AS PER THE ANNUAL ROADS PROJECT PLANS OVER A PERIOD OF 36 MONTHS

C2.1: PRICING INSTRUCTIONS

1. Measurement and payment shall be in accordance with the relevant provisions of the COLTO Standard Specification for Road and Bridge Works for State Authorities (1998 edition) as amended in the Scope of Works.
2. The units of measurement described in these Bills of Quantities are metric units. Abbreviations used in these Bills of Quantities are as follows:

%	=	Percent
H	=	Hour
Ha	=	Hectare
Kg	=	Kilogram
Kl	=	Kilolitre
Km	=	Kilometer
Km-pass	=	Kilometer-pass
KPa	=	Kilopascal
KW	=	Kilowatt
l	=	Litre
M	=	Metre
Mm	=	Millimeter
M ²	=	Square metre
M ² -pass	=	Square metre-pass
M ³	=	Cubic metre
M ³ -km	=	Cubic metre-kilometre
MN	=	Meganewton
MN.m	=	Meganewton-metre
Mpa	=	Megapascal
No.	=	Number
Prov sum	=	Provisional sum
PC sum	=	Prime cost sum
R/only	=	Rate only
Sum	=	Lump sum
T	=	Ton (1000 kg)
W/day	=	Work day

3. For the purpose of these Bills of Quantities, the following words shall have the meanings hereby assigned to them:

Unit: The unit of measurement for each item of work as defined in the COLTO Standard Specification for Road and Bridge Works for State Authorities (1998 edition).

Quantity: The number of units of work for each item.

Rate: The agreed payment per unit of measurement.
 Amount: The product of the quantity and the agreed rate for an item.
 Lump sum: An agreed amount for an item, the extent of which is described in the Bills of Quantities but the quantity of work of which is not measured in any units.

4. Unless otherwise stated, items are measured net in accordance with the drawings, and no allowance is made for waste.
5. It will be assumed that prices included in the bills of quantities are based on Acts, Ordinances, Regulations, By-laws, International Standards and National Standards that were published 28 days before the closing date for tenders. (Refer to www.stanza.org.za or www.iso.org for information on standards)
6. The prices and rates in these Bills of Quantities are fully inclusive prices for the work described under the items. Such prices and rates cover all costs and expenses that may be required in and for the execution of the work described in accordance with the provisions of the Scope of Work, and shall cover the cost of all general risks, liabilities, and obligations set forth or implied in the Contract Data, as well as overhead charges and profit. These prices will be used as a basis for assessment of payment for additional work that may have to be carried out.
7. Where the Scope of Work requires detailed drawings and designs or other information to be provided, all costs associated therewith are deemed to have been provided for and included in the unit rates and sum amount tendered such items.
8. An item against which no price is entered will be considered to be covered by the other prices or rates in the Bills of Quantities. A single lump sum will apply should a number of items be grouped together for pricing purposes.
9. The quantities set out in these Bills of Quantities are approximate and do not necessarily represent the actual amount of work to be done. The quantities of work accepted and certified for payment will be used for determining payments due and not the quantities given in these bills of Quantities.
10. Reasonable compensation will be received where no pay item appears in the Bills of Quantities in respect of work required in terms of the contract and which is not covered in any other pay item.
11. The short descriptions of the items of payment given in these Bills of Quantities are only for the purposes of identifying the items. More details regarding the extent of the work entailed under each item appear in the Scope of Work. **The Bill of Quantity included is merely a guide to cover the anticipated work to be done. The actual work to be performed will be dependent on the needs identified at the time and the estimates could therefore vary from one Section to another, to fit within the annual budget approval of the Municipality.**
12. The item numbers appearing in the Bills of Quantities refer to the corresponding item numbers in the COLTO Standard Specification for Road and Bridge Works for State Authorities (1998 edition).
13. Any enquiries regarding the tendering procedure may only be directed to –
 Ms. Maropeng Mokhatla
 Supply Chain Management
 KRUGERSDORP
 Tel: 011 951 2541
 Or:
 for Technical Information –
 Johan Britz (MCLM – ROADS AND TRANSPORT SERVICES) Tel: 011 951 2141 ; Fax: 011 660 9672

Municipality 1		Municipality 2		Contractor	
----------------	--	----------------	--	------------	--

C2.2 SCHEDULE OF QUANTITIES
PREAMBLE TO SCHEDULE OF QUANTITIES

1.0 The general conditions of contract, the special conditions of contract (if any), the specifications (including the project specification) and the drawings (if any) are to be read in conjunction with the schedule of quantities.

2.0 For the purposes of this schedule of quantities, the following words shall have the meaning hereby assigned to them:

Unit: The unit of measurement for each item of work as defined in the specifications.

Quantity: The number of units of work for each item.

Rate: The payment per unit of work for which the tenderer tenders to do the work.

Amount: An amount tendered for an item, the extent of which is described in the schedule of quantities, the specification or elsewhere, but of which the quantity of work is not measured in units.

3.0 The quantities set out in the schedule of quantities are only approximate quantities. The quantities of work finally accepted and certified for payment, and not the quantities given in the schedule of quantities, will be used to determine payments to the contractor.

The validity of the contract shall in no way be affected by differences between the quantities in the schedule of quantities and the quantities finally certified for payment. Work shall be valued at the rates or lump sums tendered, subject only to the provisions of the general conditions of contract.

4.0 Rates and lump sums shall include full compensation for overheads, profits, incidentals, tax **(except for Value Added Tax)**, etc. and for the completed items of work as specified. Full compensation for completing and maintaining, during the maintenance period, all work shown on the drawings and specified in the specifications, and for all the risk, obligations and responsibilities specified in the general conditions of contract, special conditions of contract and the project specifications shall be considered as provided for collectively in the items of payment given in the schedule of quantities, except in so far as the quantities given in the schedule of quantities are only approximate.

5.0 The tenderer shall fill in a rate or a lump sum for each item where provision is made for it, - this include rate only items. Items against which no rate or lump sum has been entered in the tender will not be paid for when the work is executed, as payment for such work will be regarded as being covered by other rates or lump sums in the schedule of quantities.

Please only complete rates and totals for those items that have entries in the quantity column – this include “rate only” items

The tenderer shall fill in a rate against all items where the words "rate only" appears in the amount column. Although no work is foreseen under such item and no quantities are consequently given in the quantity column, the tendered rate shall apply should work under this item actually be required. Tenderers should note the provisions of paragraph 12 of this preamble.

Municipality 1		Municipality 2		Contractor	
----------------	--	----------------	--	------------	--

If the tenderer should group a number of items together and tender one lump sum for such group of items and not to each individual item, or should he indicate that full compensation for any item has been included in the rate for another item, the rate for the item included in another item shall be deemed to be nil.

The tendered lump sum and rates shall be valid irrespective of any change in the quantities during the execution of the contract.

Preliminary & General Section may not be tendered as a lump sum. A tender may be disqualified if the P&G Section is tendered as a lump sum.

- 6.0 The works executed are measured for payment in accordance with the methods described in the contract documents under the various payment items.
- 7.0 The amount of work or the quantities of material stated in the schedule of quantities shall not be considered as restricting or extending the amount of work to be done or the quantity of material to be supplied by the contractor.
- 8.0 The statement of quantities of material or amount of work in the schedule of quantities shall not be regarded as authorisation for the contractor to order material or to execute the work. The contractor shall obtain the engineer's detailed instructions for all work before ordering any materials or executing work or making arrangements in this regard.
- 9.0 The short description of the payment items in the schedule of quantities is only given to identify the items and to provide specific details. Reference shall inter alia be made to the drawings, project specifications, general conditions of contract and special conditions of contract for more detailed information regarding the extent of work entitled under each item.
- 10.0 The provisions of Clause 48 of the general conditions of contract shall apply to provisional sums and prime cost sums.
- 11.0 Subject to the conditions stated in paragraph 12 below, the rates and lump sums filled in by the tenderer in the schedule of quantities shall be final and binding, and may not be adjusted should there be any mistakes in the extensions thereof and in the amounts, appearing in the tender. Should there be any discrepancies between the tender sum and the correctly extended and totaled schedule of quantities, the rates will be regarded as being correct, and the employer shall have the right to make adjustments to the tender sum to reconcile the tender sum with the total of the schedule of quantities. Under no circumstances will tendered rates be adjusted when such errors are corrected. In such an event the contractor will be consulted but, failing agreement between the parties, the decision of the employer shall be final and binding. Adjustment of the tender sum will take place only after acceptance of the tender, but prior to the signing of the contract. In their own interest tenderers must make doubly sure of the correctness of their tendered rates, the extensions and the tender sum.
- 12.0 A tender may be rejected if the unit rates or lump sums for some of the items in the schedule of quantities are, in the opinion of the employer, unreasonable or out of proportion, and if the tenderer fails, within a period of seven (7) days of having been notified in writing by the employer to adjust the unit rates or lump sums for such items, to make such adjustments.

Municipality 1		Municipality 2		Contractor	
----------------	--	----------------	--	------------	--

- 13.0 All rates and sums of money quoted in the schedule of quantities shall be in Rands and whole cents. Fractions of a cent shall be discarded.
- 15.0 The schedule of quantities shall be completed in **BLACK INK**. **Tenders where the Schedule of Quantities is completed in pencil, WILL be disqualified.**
- 16.0 All prices and rates shall exclude value added tax (VAT). **The Tenderer shall calculate VAT and enter it as the end of the Summary of the Schedule of Quantities.**
- 17.0 The item numbers appearing in the Bills of Quantities refer to the corresponding item numbers in the COLTO Standard Specification for Road and Bridge Works for State Authorities (1998 edition).

An electronic copy of the Schedule of Quantities will be made available by contacting Mogale City Supply Chain Management. It is a requirement that the original pages contained in the tender document must still be completed in black ink. A tender will be disqualified if only a printed copy of the Schedule of Quantities is submitted

Municipality 1		Municipality 2		Contractor	
----------------	--	----------------	--	------------	--

SCHEDULE OF QUANTITIES

Municipality 1		Municipality 2		Contractor	
----------------	--	----------------	--	------------	--

Section 1 - Patching; Section 2 - Resurfacing with Bituminous Asphalt,
 Section 3 - Treatment of existing surface exhibiting certain defects / Slurry's; Section 4 – Single seals

ITEM	DESCRIPTION	UNIT	QTY	RATE	AMOUNT
12	GENERAL REQUIREMENTS AND PROVISIONS				
B12.01	Standing time				
	(a) Milling team	hr	1		
	(b) Paving team	hr	1		
	(c) Road Seal team	hr	1		
	(d) Patching team	hr	1		
13	CONTRACTOR'S ESTABLISHMENT ON SITE AND GENERAL OBLIGATIONS (REFER TO PARTICULAR PROJECT SPECIFICATIONS- SECTION 1300)				
	Contractor's general obligations				
	(a) Fixed obligations per year				
	(b) Value-related obligations				
	(c) Time-related obligations (include OHSA and Construction Regulations)				
	(d) In respect of the OHSA and construction regulations				
	(e) Provision of full time Safety Officer				
	(f) Submission of Health & Safety File	sum	1		
					Lump sum (which will be 12% of works order issued. Do not submit rate or lump sum
15	ACCOMMODATION OF TRAFFIC (REFER TO PARTICULAR PROJECT SPECIFICATIONS- SECTION 1500)				
B15.01	Accommodating traffic and maintaining temporary deviation's				
	(a) Primary/Secondary - multi lanes	km	1		
	(b) Secondary - single lane	km	1		
	(c) Main Tertiary - single lane	km	1		
	(d) Tertiary - single lane	km	1		
18	Day works/ Personnel during project working hours				
B18.01	(a) Unskilled labour	Day	1	186,00	186.00
	(b) Semi-skilled labour / Interns	Day	1	256,00	256.00
	(e) CLO (Community Liason Officer), inclusive of Cellphone allowance	Month	1	6,160.00	6,160.00

Municipality 1		Municipality 2		Contractor	
----------------	--	----------------	--	------------	--

Section 3 - Treatment of existing surface exhibiting certain defects / Slurry's; Section 4 – Single seals

ITEM	DESCRIPTION	UNIT	QTY	RATE	AMOUNT
22	DRAINAGE				
22.03	Laying of pre-fabricated concrete pipes (All inclusive, Refer to Project Specifications)				
	(b) On class B bedding (Annexure B1)				
	(i) 450mm 25D storm water pipe	m	Rate only		
	(iii) 600mm 50D storm water pipe	m	Rate only		
	(iv) 750mm 50D storm water pipe	m	Rate only		
	(v) 900mm 50D storm water pipe	m	Rate only		
22.17	Manholes, cathpits and pre-cast structures complete (All inclusive, Refer to Project Specifications)				
	(a) Manholes: 0-2m max. depth (As per Annexure B5)				
	450mm dia.	No.	Rate only		
	600mm dia.	No.	Rate only		
	750mm dia.	No.	Rate only		
	900mm dia.	No.	Rate only		
	(b)(iii) Catchpits (As per Annexure B2)				
	1,5m length	No	Rate only		
	3,0m length	No	Rate only		
	4,5m length	No	Rate only		
	6,0m length	No	Rate only		
	(c)(i) Catchpits (As per Annexure B3)				
	0,9m length	No	Rate only		
	1,8m length	No	Rate only		
	2,7m length	No	Rate only		
	3,6m length	No	Rate only		
	4,5m length	No	Rate only		
	(d) Extra over or less than subitem 22.17(a) for variations in the depths of manholes from the standard depth designated from tendering purposes.	m	Rate only		
	(e)(i) Kerb - inlet slab (concrete, 25 Mpa) , As per Annexure B4				
	0,9m x0,9m 0,1m thick	No	Rate only		
	1,2m x0,9m 0,1m thick	No	Rate only		
	(e)(ii) Kerb - inlet slab (concrete, 25 Mpa) - Heavy Duty:				
	1m x1m 0,1m thick	No	Rate only		
	2m x1m 0,1m thick	No	Rate only		
22,21	Accessories:				
	(a) Manhole covers including frames (Rocla Type 2a or similar – Medium duty (Annexure B5)	No	Rate only		
	(a)(i) Concrete (25Mpa) sully and fit.				

Municipality 1		Municipality 2		Contractor	
----------------	--	----------------	--	------------	--

Section3 -Treatment of existing surface exhibiting certain defects / Slurry's; Section 4 – Single seals

ITEM	DESCRIPTION	UNIT	QTY	RATE	AMOUNT
23	CONCRETE KERBING				
23.01	(All inclusive, Refer to Project Specifications)				
	(a) Fig. 3	m			
	(b) Fig 8b	m			
	(c) Fig. 12	m			
	(d) Type C	m			
	(e) Any other types: bidder to specify _____	m			
56.01	TRAFFIC SIGNS SUPPLIED, COMPLETE WITH CLAMPS, BOLTS, NUTS & POLES				
	(a) Regulatory signs - full series (R - Series)				
	(i)Size : 600mm	No	Rate only		
	(ii) Size: 900mm	No	Rate only		
	(b) Warning Signs - full series (W - Series)				
	(i)Size : 900mm	No	Rate only		
	(c) Hazard marker Signs - (W - Series)				
	(d)(i) 1.8m x 50mm x 50mm sq tubing, painted admiral grey	No	Rate only		
	(d)(ii) 3.0m x 50mm x 50mm sq tubing, painted admiral grey	No	Rate only		
	(d)(iii) Steel round Tubing, including base plate, top blanked off, treated and painted admiral grey color (3.0m long) 1,6mm thickness	No	Rate only		
	(e) Excavations for sign supports, including backfilling with 25 Mpa Concrete (300mm x 300mm x 600mm deep) and planting the poles as per Annexure B7)	m3	Rate only		
B57.02	ROAD MARKINGS				
	Retro-reflective road-marking paint				
	(a) White lines (broken or unbroken)				
	(1) 100 mm wide - Exceeding 50 m	km	1		
	(2) 150 mm wide - Exceeding 50 m	km	1		
	(b) lines (broken or unbroken)				
	(1) 150 mm wide - Exceeding 50 m	km	1		
	(d) White lettering and symbols	m ²	1		
	(e) lettering and symbols	m ²	1		
	(f) Transverse lines, painted island (any color)	m ²	1		
	(g) Kerb markings - (black 1 m & white 1m)	m ²	1		
57.06	Setting out and pre-marking the lines	Km	1		
57.08	Removal of existing, temporary or permanent road markings by;				
	(a) Sand blasting	m ²	1		
82.01	Sampling / Testing The Contractor to obtain quotations, inclusive of 10% handling fees, for approval by the engineer, to be paid under Contingencies	PC Sum	1		50,000.00
Total Carried Forward To Summary Page: P&G'S , Road Markings, etc. (All Sections)					

Part C2.2 : Bill of Quantity

Schedule

Municipality 1		Municipality 2		Contractor	
----------------	--	----------------	--	------------	--

SCHEDULE C2.2.2

Section: 1 - PATCHING

ITEM	DESCRIPTION	UNIT	QTY	RATE	AMOUNT
39	PATCHING AND REPAIRING EDGE BREAKS				
39,01	Sawing asphalt on cemented pavement layers for patching: (a) Sawing asphalt to an average depth; (i) Not exceeding 50mm. (ii) Exceeding 50mm but not 100mm	m ² m ²	1 1		
39,02	Excavation in existing pavements for patching in; (a) Asphalt Layers (b) Cemented layers (c) Other layers (Gravel, crushed stone)	m ³ m ³ m ³	1 1 1		
39,03	Backfilling of excavations for patching with; (a) Chemically stabilized pavement material (G3 material, nominal size 26.5mm, 4% cement) (i) Not exceeding 5m ² (ii) Exceeding 5m ² but not 100m ² (iii) Exceeding 100m ²	m ³ m ³ m ³	1 1 1		
39,04	Compacting the floor of excavations for patching	m ²	1		
39,05	Cutting back the edges of the existing surfacing for the repairing of edge breaks	m	1		
41	PRIME COAT				
41,01	Prime Coat: Apply (e) Invert bitumen emulsion @ 0,8 L/m ² nominal application rate (i) Not exceeding 9000l (ii) Exceeding 9000l	l l	1 1		
42,11	Asphalt layer constructed for rehabilitation purposes in accordance with the provisions of sub clauses 4213(f)(ii) or 4213(f)(iii) (a) Base constructed with new asphalt (35/50 Pen Bitumen, 4,5% bitumen) (1) Continuously graded, BTB medium, max. 26.5 mm (ii) To various depths (b) Surfacing constructed with new asphalt (50/70 Pen Bitumen, 5% Bitumen) (1) Continuously graded, medium, max. 13.2 mm (ii) Maximum 60 mm thickness	t t	1 1		
Total Carried Forward to Summary Page (Section 1)					

Municipality 1		Municipality 2		Contractor	
----------------	--	----------------	--	------------	--

SCHEDULE C2.2.2

Section 2 - RESURFACING WITH BITUMINOUS ASPHALT

ITEM	DESCRIPTION	UNIT	QTY	RATE	AMOUNT
35, 01	<p>CHEMICAL STABILIZATION</p> <p>Base layers (all materials) compacted to the specified density, stabilized with Ordinary Portland Cement (OPC) or alternative to be specified and pre- approved: 100mm to 150mm thickness, all inclusive to construct the stabilized layer, using plant, spreading and mixing the material and stabilizing agent, supervision and labour, tools and incidentals to complete the specified work, excluding the cost for supplying the Stabilizing agent (item 35.02)</p>	m ³	1		
35,02	<p>Chemical Stabilizing Agent: (% Stabilizing agent as specified by Engineer)</p> <p>(a) Ordinary Portland Cement (OPC)</p> <p>(b) Alternative to be specified and pre-approved</p>	t	1		
		t	1		
35,03	<p>(i) IN-SITU COLD RECYCLING WORK, PAVEMENT LAYERS REHABILITATED USING AN IN-SITU RECYCLING MACHINE</p> <p>New Pavement Layers, constructed by in-situ recycling</p> <p>(a) Establishment on site: Approved in situ Recycling machine suitable for Class III and IV roads.</p> <p>(b) Levelling, compacting and preparing Recycled Asphalt Pavement (RAP) material</p>	No.	10		
		m ³	1		

Municipality 1		Municipality 2		Contractor	
----------------	--	----------------	--	------------	--

Part C2.2 : Bill of Quantity

Schedule

SCHEDULE C2.2.2

Section 2 - RESURFACING WITH BITUMINOUS ASPHALT

ITEM	DESCRIPTION	UNIT	QTY	RATE	AMOUNT
	(ii) BREAKING OF EXISTING PAVEMENT LAYERS				
35,03	Milling out existing bituminous material with an average milling depth;				
	(a) Not exceeding 30 mm	m ²	1		
	(b) Exceeding 30 mm but not exceeding 60 mm	m ²	1		
	(c) Exceeding 60 mm	m ²	1		
38,15	Moving the milling machine on site for a distance exceeding 1 km (Up to 1 m working width)	No.	1		
38,16	Fine 'milling' to improve skid resistance or to remove rutting and unevenness (max 40 mm deep)				
	(a) Not exceeding 1000 m ²	m ²	1		
	(b) Exceeding 1000 m ²	m ²	1		
39	PATCHING AND REPAIRING EDGE BREAKS				
39,01	Sawing asphalt on cemented pavement layers for patching:				
	(a) Sawing asphalt to an average depth;				
	(i) Not exceeding 50 mm.	m ²	1		
	(ii) Exceeding 50 mm but not 100 mm	m ²	1		
39,02	Excavation in existing pavements for patching in;				
	(a) Asphalt Layers	m ³	1		
	(b) Cemented layers	m ³	1		
	(c) Other layers (Gravel, crushed stone)	m ³	1		
39,03	Backfilling of excavations for patching with;				
	(a) Chemically stabilized pavement material (G3 material, nominal size 26.5 mm, 4 % cement)				
	(i) Not exceeding 5 m ²	m ³	1		
	(ii) Exceeding 5 m ² but not 100 m ²	m ³	1		
	(iii) Exceeding 100 m ²	m ³	1		
39,04	Compacting the floor of excavations for patching	m ²	1		
39,05	Cutting back the edges of the existing surfacing for the repairing of edge breaks	M	1		
41	PRIME COAT				
41,01	Prime Coat: Apply				
	(e) Invert bitumen emulsion @ 0,8 ℓ/m ² nominal application rate				
	(i) Not exceeding 9000 ℓ	ℓ	1		
	(ii) Exceeding 9000 ℓ	ℓ	1		
42	ASPHALT BASE AND SURFACING				
42	Site Establishment (for machine work) per year	Sum	1		
	(a)(i) Asphalt base, 100 mm thick (Continuously graded, 26,5 mm aggregate), not exceeding 100 Ton. 4,5 % Bitumen, 35/50 Pen Bitumen).	T	1		
42.01	(a)(ii) Asphalt base (Continuously graded, 26,5 mm aggregate), exceeding 100 Ton. 4,5 % Bitumen, 35/50 Pen Bitumen).	T	1		

Municipality 1		Municipality 2		Contractor	
----------------	--	----------------	--	------------	--

Part C2.2 : Bill of Quantity

Schedule

SCHEDULE C2.2.2

Section 2 - RESURFACING WITH BITUMINOUS ASPHALT (Cont.)

ITEM	DESCRIPTION	UNIT	QTY	RATE	AMOUNT
42,02	Asphalt Surfacing (a)(i) Continuously graded placed by machine (medium grade),4,5%, max 13,2 mm, 50/70 Pen Bitumen, exceeding 10 t (d)(i) Continuous graded placed by machine. 4, 5 %, 50/70 Pen Bitumen modified AP-1, max.19 mm aggregate, exceeding 10t.	t	1		
		t	1		
42,04	Tack coat of 30% stable grade bituminous emulsion (i) Not exceeding 9000 ℓ (ii) Exceeding 9000 ℓ	ℓ	1		
		ℓ	1		
42,05	Binder variations (a) 35/50 Pen Bitumen (b) Stable grade emulsion	t	1		
		t	1		
42,06	Variation in active filler content; (a) Cement (b) Lime	t	1		
		t	1		
42,08	100mm cores in asphalt paving (when required as per Engineers request)	No	1		
42,11	Asphalt layer constructed for rehabilitation purposes in accordance with the provisions of sub clauses 4213(f)(ii) or 4213(f)(iii) (a) Base constructed with new asphalt (35/50 Pen Bitumen,4,5% bitumen) (1) Continuously graded, BTB medium, max. 26.5 mm (ii) To various depths (b) Surfacing constructed with new asphalt (50/70 Pen Bitumen, 5% Bitumen) (1) Continuously graded, medium, max. 13.2 mm (ii) Maximum 60 mm thickness	t	1		
		t	1		
48	TREATMENT OF AN EXISTING SURFACE EXHIBITING CERTAIN DEFECTS				
48,06	Cleaning of cracks with compressed air	m	1		
48,07	Applying bituminous binders and herbicides for sealing cracks (a) Herbicides: Glyphosate (480g/l SL or similar) (d) Hot bitumen rubber	ℓ	1		
		ℓ	1		
Total Carried Forward to Summary Page (Section 2)					

Municipality 1		Municipality 2		Contractor	
----------------	--	----------------	--	------------	--

Part C2.2 : Bill of Quantity

Schedule

SCHEDULE C2.2.2

Section3 - TREATMENT OF EXISTING SURFACE EXHIBITING CERTAIN DEFECTS / SLURRY'S

ITEM	DESCRIPTION	UNIT	QTY	RATE	AMOUNT
39	PATCHING AND REPAIRING EDGE BREAKS				
39,01	Sawing asphalt on cemented pavement layers for patching:				
	(a) Sawing asphalt to an average depth;				
	(i) Not exceeding 50 mm.	m ²	1		
	(ii) Exceeding 50 mm but not 100 mm	m ²	1		
39,02	Excavation in existing pavements for patching in;				
	(a) Asphalt Layers	m ³	1		
	(b) Cemented layers	m ³	1		
	(c) Other layers (Gravel, crushed stone)	m ³	1		
39,03	Backfilling of excavations for patching with;				
	(a) Chemically stabilized pavement material (G3 material, nominal size 26.5 mm, 4% cement)				
	(i) Not exceeding 5 m ²	m ³	1		
	(ii) Exceeding 5 m ² but not 100 m ²	m ³	1		
	(iii) Exceeding 100 m ²	m ³	1		
	(b) Base material stabilized with bituminous emulsion for a patch with a surface area				
	(i) Not exceeding 5 m ²	m ³	1		
	(ii) Exceeding 5 m ² but not 100 m ²	m ³	1		
	(iii) Exceeding 100 m ²	m ³	1		
39,04	Compacting the floor of excavations for patching	m ²	1		
39,05	Cutting back the edges of the existing surfacing for the repairing of edge breaks	m	1		
41	PRIME COAT				
41,01	Prime Coat: Apply				
	(a) Bitumen emulsion prime @ 0,8 £ /m ² nominal application rate (Anionic bitumen emulsion)				
	(i) Not exceeding 9000 £	£	1		
	(ii) Exceeding 9000 £	£	1		
	(e) Invert bitumen emulsion @ 0,8 £ /m ² nominal application rate				
	(i) Not exceeding 9000 £	£	1		
	(ii) Exceeding 9000 £	£	1		
42,11	Asphalt layer constructed for rehabilitation purposes in accordance with the provisions of sub clauses 4213(f)(ii) or 4213(f)(iii)				
	(a) Base constructed with new asphalt (35/50 Pen Bitumen, 4,5% bitumen)				
	(1) Continuously graded, BTB medium, max. 26.5 mm				
	(ii) To various depths	t	1		
	(b) Surfacing constructed with new asphalt (50/70 Pen Bitumen, 5% Bitumen)				
	(1) Continuously graded, medium, max. 13.2 mm				

Municipality 1		Municipality 2		Contractor	
----------------	--	----------------	--	------------	--

(ii) Maximum 60 mm thickness	t	1		
------------------------------	---	---	--	--

Part C2.2 : Bill of Quantity

Schedule

SCHEDULE C2.2.2

Section3 - TREATMENT OF EXISTING SURFACE EXHIBITING CERTAIN DEFECTS / SLURRY'S (Cont.)

ITEM	DESCRIPTION	UNIT	QTY	RATE	AMOUNT
48	TREATMENT OF AN EXISTING SURFACE EXHIBITING CERTAIN DEFECTS				
48,01	Treatment with diluted bituminous emulsion (fog spray)				
	(a) 30% bitumen emulsion				
	(i) exceeding 9000 ℓ	ℓ	1		
	(b) 60% bitumen emulsion				
	(i) exceeding 9000 ℓ	ℓ	1		
48,03	Slurry Seal				
	(b) Slurry applied by hand				
	(i) Fine, course grade	m ³	1		
	(ii) Coarse, type 2	m ³	1		
	(c) Slurry applied by spreader box (exceeding 5 m ³)				
	(i) Fine, course grade	m ³	1		
	(ii) Coarse, type 2	m ³	1		
48,06	Cleaning of cracks with compressed air	m	1		
48,07	Applying bituminous binders and herbicides for sealing cracks				
	(a) Herbicides: Glyphosate (480g/l SL or similar)	ℓ	1		
	(d) Hot bitumen rubber	ℓ	1		
48,14	Quick- set Slurry applied by spreader box (exceeding 5 m ³) 6 mm, 190 ℓ /m ³				
	(i) Fine Slurry applied by spreader box, Medium grade SBR/SBS latex modified emulsion @ 8 mm,190 ℓ /m ³ Micro surfacing (AC-E1) Rut filling(AC-E2)	m ³	1		
Total Carried Forward to Summary Page (Section 3)					

Municipality 1		Municipality 2		Contractor	
----------------	--	----------------	--	------------	--

Part C2.2 : Bill of Quantity

Schedule

SCHEDULE C2.2.2

Section 4- SINGLE SEALS

ITEM	DESCRIPTION	UNIT	QTY	RATE	AMOUNT
42,11	Asphalt layer constructed for rehabilitation purposes in accordance with the provisions of sub clauses 4213(f)(ii) or 4213(f)(iii) (a) Base constructed with new asphalt (35/50 Pen Bitumen, 4,5% bitumen) (1) Continuously graded, BTB medium, max. 26.5 mm (ii) To various depths (b) Surfacing constructed with new asphalt (50/70 Pen Bitumen, 5% Bitumen) (1) Continuously graded, medium, max. 13.2 mm (ii) Maximum 60 mm thickness	t	1		
44	SINGLE SEALS				
44,01	(a) Using 4,75 mm washed grid aggregate exceeding 5000 m² (i) Bitumen-rubber (Grit seal @1.6 ℓ/m² or similar approved)	m ²	1		
	(c) Using 9,5mm aggregate exceeding 5000 m² (Nominal application rate of 9,5mm aggregate = 140 m²/m³)		1		
	(i) SBS @ 1,4 ℓ/m² (S-E1)	m ²	1		
	(ii) SBR @ 1,4 ℓ/m² (S-E1)	m ²	1		
	(iii) Bitumen rubber @ 1,8 ℓ/m² Bitumen Rubber with an extended shelf life of minimum 3 days and longer (NCRT or equivalent) @1,8 ℓ /m²	m ²	1		
	(iv) Modified emulsion @ 1,7 ℓ/m² (SC-E1 or SC-E2) Cationic Rapid setting emulsion 60% with resistance to flow @ 1,9 ℓ /m² (Chip seal or equivalent)	m ²	1		
	(d) Using 13.2mm aggregate exceeding 5000 m² (Nominal application rate of 13,2mm aggregate = 100 m²/m³)	m ²	1		
	(i) SBS @ 1,4 ℓ /m² (S-E1)	m ²	1		
	(ii) SBR @ 1,4 ℓ /m² (S-E1)	m ²	1		
	(iii) Bitumen rubber @ 2,1 ℓ /m²	m ²	1		
	(iv) Modified emulsion @ 1.9 ℓ /m²	m ²	1		
44,02	Bituminous binder variation: (a) SBS @ 1,4 ℓ /m ² (S-E1) (b) SBR @ 1,4 ℓ /m ² (S-E1) (c) Bitumen Rubber @2,1 ℓ /m ² (S-R1), Bitumen Rubber (S-R2) with an extended shelf life of minimum 3 days and longer (NCRT or equivalent) @ 2,1 ℓ /m ² (d) Modified Emulsion @1,9 ℓ /m ² (SC-E1 or SC-E2) Cationic Rapid setting emulsion 60% with resistance to flow @1,9 ℓ /m ² (Chip seal or equivalent) Aggregate variation (c) 9,5 mm aggregate (d) 13,2 mm aggregate	m ²	rate only		
44,05	Pre-coating the aggregate at a rate of 12 ℓ /m ³ or as specified- Pre-coating fluid: Bitu-coat/Colcote S or similar	m ³	1		

Municipality 1		Municipality 2		Contractor	
----------------	--	----------------	--	------------	--

Part C2.2 : Bill of Quantity

Schedule

SCHEDULE C2.2.2

Section 4- SINGLE SEALS (Cont.)

ITEM	DESCRIPTION	UNIT	QTY	RATE	AMOUNT
44.00B LI	SINGLE SEALS: LABOUR BASED CONSTRUCTION				
44.01B LI	Emulsion application by hand sprayer (Ian Dickie or similar), stone aggregate application by manually operated chip spreader (Chippy or similar). (c) Using 9,5 mm aggregate exceeding 2000 m ² , (Nominal application rate of 9,5 mm aggregate = 140 m ² /m ³) (i) Cationic Rapid setting emulsion 60% with resistance to flow (Chip seal or equivalent) @1,7 ℓ /m ² (d) Using 13,2 mm aggregate exceeding 2000 m ² (Nominal application rate of 13,2 mm aggregate = 100m ² /m ³) (i) Cationic Rapid setting emulsion 60% with resistance to flow (Chip seal or equivalent) @2,4 l/m ²	m ²	1		
44.02B	Bituminous binder variation: (j) Cationic Rapid setting emulsion 60% with resistance to flow (Chip seal or equivalent) Aggregate variation (c) 9,5 mm aggregate (d) 13,2 mm aggregate	m ²	1		
48	TREATMENT OF AN EXISTING SURFACE EXHIBITING CERTAIN DEFECTS				
48,06	Cleaning of cracks with compressed air	m	1		
48,07	Applying bituminous binders and herbicides for sealing cracks (a) Herbicides: Glyphosate (480g/l SL or similar) (d) Hot bitumen rubber	ℓ	1		
		ℓ	1		
Total Carried Forward to Summary Page (Section 4)					

Municipality 1		Municipality 2		Contractor	
----------------	--	----------------	--	------------	--

SUMMARY PAGE

Section 1: PATCHING

DESCRIPTION :	TENDERED AMOUNT
P&G's , ROAD MARKINGS, ETC.	
PATCHING	
SUB TOTAL:	
+ Contingencies 5%	
SUB TOTAL: CARRIED FORWARD TO FORM OF OFFER (Vat Excl)	

Section 2: ASPHALT SEALS

DESCRIPTION :	TENDERED AMOUNT
P&G's , ROAD MARKINGS, ETC.	
ASPHALT SURFACING	
SUB TOTAL:	
+ Contingencies 5%	
SUB TOTAL: CARRIED FORWARD TO FORM OF OFFER (Vat Excl)	

Section 3: SLURRY SEALS

DESCRIPTION	TENDERED AMOUNT
P&G's , ROAD MARKINGS, ETC.	
TREATMENT OF EXISTING SURFACE EXHIBITING CERTAIN DEFECTS / SLURRY'S	
SUB TOTAL:	
+ Contingencies 5%	
SUB TOTAL: CARRIED FORWARD TO FORM OF OFFER (Vat Excl)	

Section 4: SINGLE SEALS

DESCRIPTION	TENDERED AMOUNT
P&G's , ROAD MARKINGS, ETC.	
SINGLE SEALS	
SUB TOTAL:	
+ Contingencies 5%	
SUB TOTAL: CARRIED FORWARD TO FORM OF OFFER (Vat Excl)	

Municipality 1		Municipality 2		Contractor	
----------------	--	----------------	--	------------	--

PART C 3 – SCOPE OF WORKS

Municipality 1		Municipality 2		Contractor	
----------------	--	----------------	--	------------	--

C.3 SCOPE OF WORKS:

- C3.1 DESCRIPTION OF WORK
- C3.2 ENGINEERING
- C3.3 PROCUREMENT
- C3.4 CONSTRUCTION
- C3.5 LIST OF DRAWINGS

C3.6.1 PROJECT SPECIFICATIONS (Part 1)

- PS1 CONTRACT DETAILS
- PS2 CONSTRUCTION DOCUMENTATION REQUIRED
- PS3 SITE FACILITIES AVAILABLE
- PS4 SITE FACILITIES REQUIRED
- PS5 ASPECTS REQUIRING SPECIAL ATTENTION
 - 5.1 Site Maintenance & Security
 - 5.2 Existing Services
 - 5.3 Testing & Quality Control
 - 5.4 Removal of Trees
 - 5.5 Accommodation of Other Contractors
 - 5.6 Subcontractors
 - 5.7 Opening & Closing Down of Borrow Pits
 - 5.8 Adjacent Residential Area
 - 5.9 Blasting Operations and Requirements
 - 5.10 Beacons & Pegs
 - 5.11 Surveying
- PS6 AS-BUILT DRAWINGS
- PS7 SAMPLES
- PS8 NOTICES, SIGNS & BARRICADES
- PS9 WORKMANSHIP & QUALITY CONTROL
- PS10 SPOIL MATERIAL
- PS11 TRENCHES
- PS12 TRANSPORT OF MATERIAL
- PS13 EMPLOYMENT OF LOCAL LABOUR
- PS14 REFERENCES IN SCHEDULE OF QUANTITIES
- PS15 RATES ALL INCLUSIVE
- PS16 ESCALATION
- PS17 ACCOMMODATION OF TRAFFIC
- PS18 EARTHWORKS – HAULAGE
- PS19 OCCUPATIONAL HEALTH & SAFETY ACT
- PS20 APPLICABLE STANDARDISED SPECIFICATIONS & REGULATIONS
- PS21 STATUS

Municipality 1		Municipality 2		Contractor	
----------------	--	----------------	--	------------	--

C3.6.2 PROJECT SPECIFICATIONS (Part 2)

- 1100 DEFINITIONS AND TERMS
- 1500 ACCOMODATION OF TRAFFIC
- 1600 OVERHAUL
- 1800 DAYWORKS
- 2200 DRAINAGE
- 2300 CONCRETE KERBING
- 3200 SELECTION, STOCKPILING AND BREAKING DOWN OF MATERIAL
- 3800 BREAKING UP EXISTING PAVEMENT LAYERS
- 4200 ASPHALT BASE AND SURFACING
- 4400 SINGLE SEALS
- 4800 TREATMENT OF AN EXISTING SURFACE EXHIBITING CERTAIN DEFECTS
- 5700 ROAD MARKING
- 8200 QUALITY CONTROL

C3.7 GENERIC SPECIFICATION - OCCUPATIONAL HEALTH & SAFETY

Municipality 1		Municipality 2		Contractor	
----------------	--	----------------	--	------------	--

C3 SCOPE OF WORKS

C3.1 DESCRIPTION OF THE WORKS

C3.1.1 Employer’s Objectives

Rehabilitation and resurfacing of roads on as per the Annual Roads Project Plans over a period of 36 months period. The works in this contract are to be executed by using both conventional construction equipment and labour intensive methods,

The “Bill of Quantities” will be determined from time to time when orders are issued to execute work. The “Contract” shall be the total as reflected by the works order issued from time to time and will be subject to budget approval by the Municipality.

C3.1.2 The work to be performed is within the area of jurisdiction of the Mogale City Local Municipality.

C3.1.3 Extent of the Works

The works will be divided into four sections, as follows:

- **Section 1:** Patching (pothole repairs, etc)
- **Section 2:** Asphalt base and surfacing.
- **Section 3:** Treatment of bituminous road surfaces exhibiting certain defects:
Slurry seals & Micro surfacing, etc.
- **Section 4:** Single & Double Seals.

The estimated quantities for the three respective years are:

Year	Section 1		Section 2		Section 3			Section 4			
	Unit	Qty	Unit	Qty	Unit	Qty		Unit	Qty	Unit	Qty
								13.2mm			9.5mm
1	Ton	1000	Ton	2500	m ³	1600	*	m ²	25 000	m ²	47 600
					m ³	200	#				
2	Ton	1000	Ton	2500	m ³	1600	*	m ²	25 500	m ²	52 400
					m ³	200	#				
3	Ton	1000	Ton	2500	m ³	1600	*	m ²	25 000	m ²	57 600
					m ³	200	#				

Notes:

= Quick-set Latex Modified Slurry, Medium grade SBR/SBS latex modified emulsion

* = Slurry Seals: Fine, course grade and Course, type 2

The extent will be defined from time to time, as and when required in the Bill of Quantities, subject to budget approval by the Mogale City Local Municipality.

The description of the work contained in the Scope of Work is merely an outline of the work to be executed in terms of the contract, and shall not limit the work to be carried out by the Contractor. The planned program for each year will be provided to the Contractor by Mogale City before commencement of the work for each year.

Municipality 1		Municipality 2		Contractor	
----------------	--	----------------	--	------------	--

SCOPE OF WORKS

The extend as defined from time to time, on an as and when required basis will include the following:

- I. Compiling and submission for approval of a detailed site safety plan and construction method statement.
- II. Compiling and submission of quality management plans for approval by the Engineer.
- III. Submission of mix-designs for approval by the Engineer.
- IV. Maintaining an electronic copy (xl sheet) of all works as measured for payment purposes, including road lengths, names, widths and areas completed for submission to the Engineer when required.
- V. Structured and detailed interaction by the contractor with various role players to ensure timeous completion of the works for each shift. These role players include the Mogale City Traffic Department.
- VI. The establishment on site of the campsite for construction equipment, plant, site offices and maintenance area.
- VII. The rehabilitation and resurfacing of various road pavements using:
 - Bituminous asphalt for Pothole Patching, etc. (Section 1)
 - Bituminous asphalt on existing bituminous road surfaces (Section 2)
 - Bituminous single seals on existing bituminous road surfaces (Section 4)
 - Bituminous slurry seals for the treatment of bituminous road surfaces exhibiting certain defects (Section 3)
 - Base material stabilized with cement, bituminous emulsion and/or Asphalt Surfacing for patching repairs on existing bituminous road surfaces (Section 1,2,3&4)
- VIII. Cleaning the construction area after each work shift to the satisfaction of the Engineer.
- IX. Cleaning of the road surface before commencement of any rehabilitation or resurfacing work undertaken, including the removal of weeds and sand.
- X. Referencing and surveying of all existing Road Markings before the start of the rehabilitation work.
- XI. Reinstatement of the original paint marking after completion of the works.
- XII. Demarcating of work area and safety where the construction area will be demarcated in accordance with the SA Traffic Manual and the required temporary signs, markings erected and/or applied in co-operation with the Traffic Department of the Mogale City Local Municipality. The Contractor shall nominate his traffic safety officer who will fulfill the duties as specified and communicate with the Traffic Department.
- XIII. The measurement of all completed works by the Contractor and the Municipality's representative for invoicing purposes.
- XIV. Quality Control and testing as directed by the Engineer and specified in the Contract.
- XV. The application of road markings, which entails the following:
 - Permanent marking of the road surface with white, and red or road painted lines or symbols using standard or retro reflective road-marking paint supplied by the Contractor.

Municipality 1		Municipality 2		Contractor	
----------------	--	----------------	--	------------	--

SCOPE OF WORKS

- Permanent marking of the road surface with white, or road painted lines or symbols using thermo-plastic road-marking paint supplied by the Contractor.
- Removal of existing, temporary or permanent road markings.

XVI Minor construction works, reinstatement of damaged Kerbs, storm water inlets and Pipes as required

XVII Install road furniture (signeage, poles, etc, as directed by the Engineer

Municipality 1		Municipality 2		Contractor	
----------------	--	----------------	--	------------	--

C3.2: ENGINEERING

C3.2.1 Design Services and Activity Matrix

The responsibilities for design and related documentation are as follows:

DESCRIPTION	RESPONSIBILITY
Design approval	Mogale City / Appointed Consultant
Proposed construction program and drawings (list of roads to be resurfaced/rehabilitated for the year)	Mogale City / Appointed Consultant
Submission of Materials design	Contractor / Appointed Consultant

C3.2.2 Employer’s Design

The extent of the Employer’s requirements is indicated in the documentation.

C3.2.3 Drawings

The reduced drawings will be issued as and when required.

The drawings shall not be used by the Contractor for any purpose other than the execution of the works.

Only figured dimensions on the drawings shall be used, and drawings shall not be scaled. The Engineer shall supply any figured dimensions, which have been omitted from the drawings. The levels given on the structural drawings are subject to confirmation on the site, and the Contractor shall submit all levels to the Engineer for confirmation before he commences any structural construction work. The Contractor shall also check all clearances given on the drawings and shall inform the Engineer of any discrepancies.

The Engineer may issue additional drawings as necessary to the contractor from time to time during the progress of the works. The Contractor shall timeously notify the Engineer of the priority in which drawings and details are required.

Before a Certificate of Completion will be issued all as-built data (e.g. roads resurfaced etc.) must be provided to the Engineer on completion of the Permanent Works. The data must be provided in electronic format or where appropriate marked up on the set of drawings provided by the Engineer. Any information in the possession of the contractor necessary for the Resident Engineer to complete his as-built drawings shall be supplied to the Resident Engineer on a regular basis and all information must be delivered before a Certificate of Completion will be issued.

C3.2.4 Design Procedures

Materials design to comply with the Applicable Standard Specifications and Particular Project Specifications

Municipality 1		Municipality 2		Contractor	
----------------	--	----------------	--	------------	--

C3.3: PROCUREMENT

C3.3.1 Preferential Procurement Procedures

The Works shall be executed in accordance with the requirements specified in Section T1.2, Tender Data (Clause F3.11) and submitted by the Contractor in his Returnable Schedules.

C3.3.2 Subcontracting

Refer to the requirements of clause F1.6.3 in the Tender Data

C3.4: CONSTRUCTION

C3.4.1 Works Specifications

a) Applicable Standard Specifications

The Standard General and Technical Specifications shall be the COLTO – Standards Specifications for Road and Bridge Works for State Road Authorities (1998).

The Standard Specifications forming part of this contract have been written to cover all phases of work usually encountered on road and bridge contracts and may therefore cover items of work not encountered in this particular contract.

The Contractor is responsible for ensuring that he is thoroughly familiar with all the amendments and corrections before submitting his tender.

b) Particular (Project) Specifications

In certain clauses the Standard Specifications allow a choice to be specified in the Particular (Project) Specifications (C3.6) between alternative materials or methods of construction and for additional requirements to be specified to suit a particular Contract. Details of such alternatives or additional requirements applicable to this Contract are contained in the Particular (Project) Specifications (C3.6). It also contains some additional specifications required for this particular Contract.

c) Certification by Recognized Bodies

Where required, Standards South Africa (SABS) must undertake the certification of items for inclusion in the Works.

C3.4.2 Plant and Materials

a) Materials, Samples and Shop Drawings

Where required, requirements for proof of compliance with materials specifications, submission of samples of materials and finishes, requirements for shop drawings, are stated in the standard or project specifications. This will also apply to the subcontracts.

Municipality 1		Municipality 2		Contractor	
----------------	--	----------------	--	------------	--

SCOPE OF WORKS

C3.4.4 Construction Equipment

a) Requirements for Equipment

As indicated in the Project Specifications

b) Equipment Provided by the Employer

None

C3.4.5 Existing Services

Specifications related to existing services are provided in the Project Specifications.

C3.4.6 Site Establishment

a) Services and Facilities Provided by the Employer

Approval for the establishment of a construction camp must be obtained from Mogale City Local Municipality. The Contractor is responsible for all arrangements for obtaining approval, establishment and subsequent removal and reinstatement of his construction camp. The contractor will have to provide 24 hour security at the entrance gate. The internal security for the contractor's plant and equipment shall be for the cost of the contractor. Security personnel may be allowed to overnight within the camp.

All regulations and local authority ordinances, as regards smoke emissions and noise abatements shall apply and compliance will be enforced as well as height restrictions and any required obstacle markers.

b) **Facilities Provided by the Contractor**

The contractor will be required to erect a fence around the construction camp. The cost thereof is regarded to be included in the relevant rates for establishment on site.

The contractor shall make his own arrangements for the supply of electrical power, water telecommunication services, ablution facilities, sewer services, first aid facilities and other services, the payment thereof and all reinstatements required upon completion. No direct payment will be made to the Contractor for the provision of electrical and other services. The cost thereof shall be deemed to be included in the rates and amounts tendered for the various items of work for which these services are required.

The storage of fuels in tanks may be kept in the contractor's camp subject to the regulations of the authorities that require a berm or wall around the installation sufficient to retain the capacity fuel of the tanks.

The Contractor shall make his own arrangements for telephone and facsimile facilities.

c) **Storage and Laboratory Facilities**

The contractor will be required to make use of an accredited laboratory to undertake nominal material testing for the Engineer on site. The contractor may also provide test results from their suppliers, provided that an accredited laboratory performed the material testing.

Municipality 1		Municipality 2		Contractor	
----------------	--	----------------	--	------------	--

SCOPE OF WORKS

d) Other Facilities and Services

The Contractor shall be responsible for the removal of all waste generated, and the proper disposal thereof elsewhere at his own cost.

If required by the Engineer, the Contractor shall supply portable chemical toilet facilities at the construction site for his staff as well as for the Engineer's supervisory staff. These facilities must be erected, and removed, and regularly serviced to the satisfaction of the Engineer.

e) Advertising Rights

Only one sign board each, for the Contractor and his subcontractors may be erected adjacent to the construction camp along the fence.

f) Notice Boards

A construction notice board complying with the SAICE specifications must be provided and erected at a position to be agreed with the Engineer. The cost of the supply and erection of this notice board must be included in the establishment cost of the Contractor.

C3.4.7 Alterations, Additions, Extensions and Modifications to Existing Works

The Contractor must satisfy himself that the dimensional accuracy, alignment, levels and setting out of existing components are compatible with the proposed Works. Where this is not the case the Engineer's Representative must be notified in writing at the earliest possible time.

C3.4.8 Water for Construction Purposes

The Contractor must make all arrangements for the transport, storage and distribution of water required for construction purposes and his own use.

Should a standpipe be required from the Municipality this must be arranged with the Section: Water and Sanitation and the required deposit will be payable in advance before a standpipe will be issued. The standpipe will be metered and the cost of the water used will be deducted from the deposit amount paid to the Municipality.

C3.5: MANAGEMENT

C3.5.1 Management of the Works

a) Planning and Programming

The Contractor's programme must be based on the milestone dates for completion specified in Table C3.5.1 below and the Working Hours defined as 08:00 to 17:00 daily. Penalties will be imposed if these Interim Milestone dates are not achieved.

The Contractor must draw up his own programme that complies with all requirements of this project and which suits his own resources.

TABLE C3.5.1: INTERIM MILESTONE DATES

Milestone	Date not later than (Week from Commencement Date)
As and when required and agreed	

Municipality 1		Municipality 2		Contractor	
----------------	--	----------------	--	------------	--

SCOPE OF WORKS

b) **Sequence of the Works**

An indication of the stated priorities as shown on the drawings of the road network according to the latest pavement management system (2012) survey.

c) **Methods and Procedures**

The methods and procedures that must be complied with are contained in Volumes 2, 3, 4 and 5 of the contract documentation. These include but are not limited to:

- Methods and Procedures in the Standards Specifications (Volume 2).
- Methods and Procedures in the Particular Specifications (C3.6).
- Occupational Health and Safety Specifications (C3.7.1).

Quality Plans and Control

d)

The requirements for Quality Plans and Control is stated in the Particular Specification (C3.6.12).

e) **Construction Method Statement**

Within 14 days of the Commencement Date the Contractor shall submit a Construction Method Statement to the Engineer for approval by the Employer. Once approved, this Statement will form part of the Contract Document.

The Method Statement shall include:

- i. All measures to be implemented to comply with traffic safety.
- ii. All measures to be implemented to comply with the requirements of the OHS Act.
- iii. A contingency plan to deal with interruptions of shifts by inclement weather, plant breakdowns or emergency closures of the work areas.
- iv. Special measures, such as availability of back-up plant, to be implemented in normal shifts to comply with the Particular specifications.

f) **Other contractors on Site**

Other contractors may work in areas adjoining the road surface areas for rehabilitation.

g) **Testing, Completion, Commissioning and Correction of Defects**

The following requirements and/or procedures shall apply:

Procedures for testing, completion, commissioning and correction of defects shall be presented to the Engineer for approval.

h) **Recording of Weather**

The contractor shall provide a rain gauge and maximum/minimum thermometer. He shall erect them according to the requirements of the weather bureau. The contractor shall record and keep a record of the daily rainfall, maximum/minimum temperatures and provide the data to the Engineer on a daily basis.

The cost of complying with these requirements is deemed to be covered by the tendered rates for the Contractor's General Obligations.

Municipality 1		Municipality 2		Contractor	
----------------	--	----------------	--	------------	--

SCOPE OF WORKS

i) Extension of time resulting from inclement weather and delays caused by actions of the employer

Delete the entire clause and replace with the following:

Change the existing heading of clause 1215 to read as above and wherever the expression 'abnormal rainfall' is encountered replace it with '*inclement weather*' and make the following changes to *Method (ii) (Critical-path method)* which will apply to this Contract:

Add the following as a new paragraph:

"a) Extension of time resulting from abnormal rainfall or other forms of inclement weather shall be calculated according to the requirements of Method (ii) (Critical-path method). The value of "n" working days per calendar month as specified in this clause shall be as given in Table B1215/1 below. If no abnormal rainfall or other inclement weather periods occur during a specific calendar month (or months), the n-values as specified shall not be taken as accumulating over the contract period. If the "n"-days allowed for in the programme of work are not taken up by standing time due to abnormal rainfall or inclement weather conditions, they will fall away and will not be considered in extension of time claims that may arise later during the contract period.

Table B1215/1: Average ('n') delays due to inclement weather

Month	Jan*	Feb	Mar	Apr	May	Jun	Jul	Aug	Sep	Oct	Nov	Dec*
'n' days delay	8	6	5	3	0	1	1	0	0	2	5	3

*If the Contractor programme to close during the traditional Christmas/New Year break, the days for December and January shall be reduced as shown in brackets.

The value 'n' is the average number of days on which more than 5 mm of rain has been measured by the weather station at Mogale for the period 2004 to 2005.

The Engineer's Representative will certify a shift loss due to abnormal rain or adverse weather conditions based on the following criteria:

- i) No work was possible during the relevant shift on any item which is on the critical path according to the latest approved construction programme, or if
- ii) Less than 50% of the work force and plant planned for that specific shift could work.

Actual extensions of time due to inclement weather shall be agreed between the Engineer's and Contractor's representatives on the site. The agreed shifts or parts thereof shall be recorded at the bi-weekly site meetings and adjustments made to the contract period on a bi-weekly basis by extending the contract period according to the number of shifts lost less the allowance 'n'. At the end of the contract, the Engineer shall prepare a variation order to formalize the payment of the accumulated delays in excess of the allowance due to inclement weather.

Municipality 1		Municipality 2		Contractor	
----------------	--	----------------	--	------------	--

SCOPE OF WORKS

- b) Extension of time resulting from delays during shifts caused by operations of the Employer shall be allowed for in the contractor's programme. The number of working days to be allowed for in the Contractors programme is 4 days for the full contract period. The criteria listed in (i) and (ii) above will also apply to this extension of time.

Time lost during shifts shall be agreed between the Engineer's and Contractor's representative on site. The agreed shifts or parts thereof shall be recorded at the bi-weekly site meetings and adjustment made to the contract period on a bi-weekly basis by extending the contract period according to the number of shifts lost less the allowance. At the end of the contract, the Engineer shall prepare a variation order to formalize the payment of the accumulated delays due to Employers operations."

j) Format of Communications

All instructions or requests need to be confirmed in writing through:

- Site instructions.
- Requests for inspections/approvals.

k) Key Personnel

The Contractor and Engineer must compile a schedule of their Key Personnel with their contact numbers and keep it updated. The list must be made available to the Engineer, Employer and Contractor.

l) Management Meetings

The following formal meetings will be held at the office of the Engineer's Representative between the representatives of the Employer, Engineer and the Contractor:

- Progress meeting (frequency to be determined by the Engineer)
- Monthly technical meeting (Date and time to be agreed by attendees).

The representatives must have the necessary delegated authority in respect of aspects such as planning, change management and health and safety.

m) Daily Records

The Contractor must keep daily records of resources (people and equipment employed) and site diaries in respect of work performed on the site. A copy of the previous day's daily record must be provided to the Engineer on a daily basis.

n) Bonds and Guarantees

Copies of the bonds and guarantees must be lodged at the office of the Mogale City Local Municipality. On release of the bond and guarantees, they can be collected from Mogale City Local Municipality.

o) Payment Certificates

The Engineer's certificate will be issued only after receipt, by him, of a draft certificate prepared by the Contractor at his own expense in the form prescribed by the Engineer. The cost of duplicating and

Municipality 1		Municipality 2		Contractor	
----------------	--	----------------	--	------------	--

SCOPE OF WORKS

delivering copies of the certificate to the contractor, the Engineer and the Employer shall be borne by the contractor. The Engineer and the employer shall require three (3) sets of A4-sized paper copies in total.

p) Insurance Provided by the Employer

For information on the Employer Insurance refer to Clause 32, 33 and 35 Section C1.2.

q) Extent of Works

1. Resurfacing of roads for the next three years (2021 to 2024), with the following Surfacing seals and Road Classes identified:

Description:	Estimated Quantities for the next 3 years		
	First Year	Second Year	Third Year
Bill of Quantities – Section 1: Patching. Primary Routes, Secondary Routes & Main Tertiary Routes	1000 Ton	1000 Ton	1000 Ton
Bill of Quantities – Section 2: Asphalt Surfacing. Primary Routes, Secondary Routes & Main Tertiary Routes	2500 Ton	2500 Ton	2500 Ton
Bill of Quantities – Section 3: Treatment of bituminous road surfaces exhibiting certain defects: Slurry Seals. Main Tertiary Routes, Tertiary Routes	1800 m ³	1800 m ³	1800 m ³
Bill of Quantities – Section 4: Single Seals. Primary Routes, Secondary Routes & Main Tertiary Routes	72 600m ²	77 900m ²	82 600m ²

2. Light rehabilitation of Roads (including milling to a maximum depth of 40mm) will be performed as instructed by the Engineer. It is not envisaged that Heavy (3 pavement layers) and Medium (2 pavement layers) Rehabilitation of roads will be performed under this contract.
3. Examples of typical Roads with their Route include:

Primary Roads (P)	Secondary (S)	Main Tertiary (T)	Tertiary (t)
Paardekraal	Nicolas Smit	Azaad Avenue	Nobelungu
Voortrekker	Johan Jonker	Ratchet	

Health and Safety

a) Health and Safety Requirements and Procedures

Health and Safety requirements and procedures are presented in Section C3.7.1.

b) Accommodation of Traffic

Requirements for the provision and usage of barricades, signs and markings are stated in the Specifications.

Municipality 1		Municipality 2		Contractor	
----------------	--	----------------	--	------------	--

PART 1 : GENERAL

C3.6.1 PROJECT SPECIFICATIONS – PART 1

PS1. CONTRACT DETAILS

REHABILITATION AND RESURFACING OF ROADS ON AS PER THE ANNUAL ROADS PROJECT PLANS OVER A PERIOD OF 36 MONTHS

General

- Establishment of Contractor's camps and the moving of plant onto the site.
- Clearing and grubbing of construction footprint
- Security & Maintenance of campsite & all of the construction works
- Compile and submit for approval a detailed site safety plan and construction method statement.
- Compile and submit a quality management plan for approval by the Engineer.
- Structured and detailed interaction with various role players to ensure timeous completion of the works for each shift. .
- Cleaning of the construction area after each work shift to the satisfaction of the Engineer

The description of the work contained in this Scope of Work is merely an outline of the work to be executed in terms of the contract, and shall not limit the work to be carried out by the Contractor and design professional. The Municipality reserves the right to interchange any road listed with another road in the vicinity.

Approximate quantities of each type of work are given in the Schedule of Quantities.

Municipality 1		Municipality 2		Contractor	
----------------	--	----------------	--	------------	--

PS2. CONSTRUCTION DOCUMENTATION REQUIRED

PS2.1 Construction Program

The tender will be awarded as soon as practical.

The time limit for submission of a program is at 14 days from date of the Site Handover. The Contractor to take cognizance of other contractors that maybe employed on the same project and coordinate and plan works accordingly.

The program should demonstrate the activities (including their interrelationship to each other), which the contractor intends to deploy in order to complete the work in the contract. In addition the program shall include:

- The starting date, date of possession of the Site and contractual date for completion of the Works.
- The date when the Contractor plans to complete the Works,
- The work of the Employer and others as stated in the Scope of Work.
- The dates when the Contractor plans to complete work needed to allow the Employer and others to do their work.
- Provisions for float, time risk allowances, health and safety requirements and other procedures set out in the contract.
- The dates when, in order to carry out the work in this contract, the Contractor will need acceptances (of drawings, design and the like), “free issue” plant and materials or other things to be provided by the Employer in terms of the contract.
- Method statements demonstrating the extent of resources of people, facilities and equipment the contractor intends to apply to principal activities shown on the program.

If the program submitted by the Contractor in terms of Clause 5.6 of the General Conditions of Contract, has to be revised because the Contractor is falling behind in his program, he shall submit a revised program of how he intends to regain lost time to ensure completion of the Works within the period defined in Clause 5.12 of the General Conditions of Contract or within a granted extension of time. Proposal to increase the tempo of work must incorporate positive steps to increase production either by more labour and Plant on the Site, or by using the available labour and Plant in a more efficient manner.

Failure on the part of the Contractor to submit or to work according to the program or revised program shall be sufficient reason for the Engineer to take steps as set out in Clause 5.13 of the General Conditions of Contract.

The approval by the Engineer of a program shall have no contractual significance other than that the Engineer will be satisfied if the work is carried out according to the program. The said approval shall not limit the right of the Engineer to instruct the Contractor to vary the program if necessary. The Contractor is also referred to Project Specifications PS3, PS 4 & PS17 when he prepares this program.

PS2.2 Safety Plan

Municipality 1		Municipality 2		Contractor	
----------------	--	----------------	--	------------	--

SCOPE OF WORKS

Within fourteen days after award of the contract, the Contractor must submit a detailed Safety Plan in accordance with OHSA (Refer to Check List in this tender document). The Safety Plan must detail safety procedures and measurements in which he proposes to carry out the Works. If accepted, the Contractor must execute the works in strict accordance with the Plan. [*Refer to Health & Safety Compliance Form Included in this tender document*]

Safety measures for excavations and trenching will be in accordance with SABS 1200 DM Clause 5.1.1.1 & 5.1.1.2.

PS2.3 Labour Schedule

The following information must be provided by the Contractor at each site meeting to be held every second week: (*Schedules to be faxed to Engineer's Office before each meeting*) [*EPWP forms are attached to this tender*]

- * Number of total labour force
- * Number of person-days of employment
- * Number of local labour (Listed: Adult Male / Female / Youth Male / Female / Disabled)
- * Minimum day-task rate earned on project
- * Non-Accredited Training provided since previous meeting
- * No of persons who have attended a standard EPWP 10 day accredited training course
- * Equipment on site
- * Expenditure on human resources (all labour costs)

PS2.4 Site Instruction Book

Contractor must supply a triplicate site instruction book. Only the Engineer will be allowed to remove pages from the site instruction book. All site instructions to be number consecutively and signed by the Engineer or his representative and these instructions shall form part of the contract documentation, while payment for this item is deemed to be included in the P&G items.

PS2.5 Rehabilitation Plan & Environmental Management Plan (EMP)

The Environmental Management Plan (EMP) for the site of the Works can be obtained from Mogale City Local Municipality.

The Contractor shall comply with all the requirements laid down in the EMP and the associated Record of Decision. The Contractor shall acquaint his employees with the provisions, regulations, duties, obligations and prohibitions, and shall accept sole liability for due compliance with the duties, obligations and prohibitions and absolve the Employer from being obliged to comply with the aforesaid duties, obligations and prohibitions.

In case of failure on the part of the Contractor to comply with the requirements of the EMP the Employer shall be entitled to employ and pay other persons to carry out any remedial work to rectify any consequence resulting from the non-compliance by the Contractor and all cost consequent or incidental thereto shall be borne by the Contractor and shall be recoverable from him by the Employer. If it is not practical to rectify any consequence resulting from the non-compliance of the Contractor with the EMP

Municipality 1		Municipality 2		Contractor	
----------------	--	----------------	--	------------	--

SCOPE OF WORKS

the Employer will be entitled to impose a penalty on the Contractor which penalty shall be in relation to the expense which the Contractor would have incurred to comply.

The Contractor shall indemnify the Employer and the Engineer against responsibility for damage to the environment on the site of the Works by completing the "Agreement Form A1 included in Part 3 of the Contract, before commencement of construction.

PS2.6 Registration of Project at Department of Labour

The contractor must register this project at Department of Labour within 3 weeks (21 days). This is necessary in order for local labour to obtain Life Skills, AIDS Related Training and Introduction to the World of Work training from the Department of Labour. As proof of registration a photocopy of the original registration form with the original ink stamp of the local Department of Labour, as well as the protocol registration number. [Refer to Labour Registration Form included in this tender document]

PS3 SITE FACILITIES AVAILABLE

PS3.1 Camp Site

A specific Site will be allocated to the appointed Contractor for his construction camp, toilet/ablution facilities and offices and will be pointed out to the contractor at the compulsory site inspection.

The construction site must be fenced and all the Contractor's activities restricted to these areas. The security of the compound and construction site will be the responsibility of the Contractor. During construction the Site of the Works shall be kept and left in a clean and orderly condition. The Contractor shall store materials and equipment for which he is responsible in an orderly manner, and shall keep the Site free from debris and obstructions.

PS 3.2 Water

Water for construction purposes only can be made available at normal tariff and rates costs payable to be Municipality. Should a standpipe be required from the Municipality this must be arranged with the Section: Water and Sanitation and the required deposit will be payable in advance before a standpipe will be issued. The standpipe will be metered and the cost of the water used will be deducted from the deposit amount paid to the Municipality. The provision for an on-site connection position can not be guaranteed and water must be carted to the point of usage. The contractor must allow to provide potable drinking water to labour on site at all times.

PS 3.3 Electricity

As for Water (PS 3.2)

PS 4 SITE FACILITIES REQUIRED

PS 4.1 Facilities for the Engineer

Municipality 1		Municipality 2		Contractor	
----------------	--	----------------	--	------------	--

SCOPE OF WORKS

Not required.

PS 4.2 Sewerage

Two portable Toilets must be provided at a designated area which will be pointed out to the contractor on site. Facilities must be constructed/provided in accordance with local authority requirements and Mogale City residential areas Homeowners Association house rules.. Where a sewer connection cannot be provided, the contractor must provide chemical toilets at the camp and on the different work fronts. Chemical toilets must be services regularly

No separate payment will be made for obtaining and distributing water, electricity and sewage, the cost of which will be deemed to be included in the tendered rates.

PS 4.3 Site Instruction Book

A triplicate book for Site Instructions shall at all times be kept on the Site.

PS.4.4 Laboratory facilities

Not required, refer to PS 5.3 & PS 6.2

PS.4.5 Tender Notice Board

Not required.

PS4.6 Landline Telephone

Not required

PS4.7 Rain Gauge

The contractor will be required to erect a rain gauge at the site office to record daily rainfall figures in the Site Instruction Book. The reading of the rain gauge shall be made at 08h00 of each working day for the duration of the contract. The records shall be submitted weekly to the Employer's Agent (the Engineer) together with a statement recording the Contractor's opinion of the effect on his programme of any weather condition that he may consider to be abnormal. The Engineer shall adjudge the extent of the delays that are attributable to "abnormal climatic conditions" [in terms of GCC 2015 Clause 5.12 and Special Conditions of Contract.](#)

No separate payment shall be made for this item and it shall be deemed to be included in the other payment items.

PS5. ASPECTS REQUIRING SPECIAL ATTENTION

PS5.1 Site Maintenance & Security

Trees, other than those to be removed for the Contract, shall be protected from damage.

Municipality 1		Municipality 2		Contractor	
----------------	--	----------------	--	------------	--

SCOPE OF WORKS

During progress of the work and upon completion thereof, the Site of the Works shall be kept and left in a clean and orderly condition. The Contractor shall store materials and equipment for which he is responsible in an orderly manner, and shall keep the Site free from debris and obstructions.

Each Contractor will be responsible for his own security at the camp site as well as the site of work for the full duration of the contract.

PS5.2 Existing services

The services indicated on the plans are not necessarily correct and **all services must be located using hand labour**. At the start of the Tender the Contractor must arrange with the different service owners to indicate their services and to certify the location and depth thereof in the site book. The availability of each service department shall not be guaranteed by the Client.

The different service owners include Telkom, Eskom and the Municipality. The existing services on site will be indicated prior to construction and must be protected for the duration of the contract. The requirements of the service owners must strictly be adhered to.

Existing services must be located by hand and is measured separately in the Schedule of Quantities. All services must be protected against damage and any damage to services pointed out to the contractor or shown on plans or that can be reasonably determined through contacting services departments, will be for the account of the Contractor.

The Contractor's attention is drawn to SABS 1200A Item 5.4. The contractor shall be responsible for immediately notifying the Authorities concerned regarding any damage caused to public services and existing works. The Engineers Representative will also be notified without delay.

PS5.3 Testing and Quality Control

The Contractor may engage the services of an approved independent laboratory for the testing of materials and the quality testing of layerworks, to ensure that his work complies with the Specifications. at own cost.

No separate payment will be made for such a laboratory or testing, the cost of which will be deemed to be included in the Contractor's tendered rates for the items of work that require testing in accordance with the Specifications.

All material must, where applicable shall carry the SABS mark.

PS5.4 Removal of trees and other vegetation

No trees or vegetation may be removed without the prior written approval from the engineer or Mogale City residentail areas Estate Manager.

PS5.5 Accommodation of Other Contractors

Municipality 1		Municipality 2		Contractor	
----------------	--	----------------	--	------------	--

SCOPE OF WORKS

In addition to the requirements of **Clause 4.8 of the General Conditions of Contract (GCC 2015)**, the Contractor must make allowances for other Contractors on the Site. This may involve adapting his program to accommodate the work of other Contractors and ensuring access to their sites along prescribed routes over the Site of this Contract. This must be considered when the works program is compiled as no extra claims will be entertained in this regard.

PS5.6 **Subcontractors**

It is a requirement of this contract, **that only local subcontractors shall be used** to carry out any subcontractor tasks.

In addition to the requirements of Clause 4.10 of the General Conditions of Contract, the Contractor shall be responsible for work carried out by subcontractors on his behalf. The Engineer will not liaise directly with such subcontractors. Problems related to payments, programming, workmanship, etc, shall be the concern of the Contractor and the subcontractor, and the Engineer will not become involved except in the case of the nominated subcontractor and only on overall performance and issues that relate to payment between the main contractor and nominated subcontractor. Subcontractors to be listed in Schedule E2.

Where local subcontractors are registered for a Specific discipline, these local subcontractors shall be used in preference to any outside subcontractor.

PS5.7 **Opening Up and Closing Down Borrow Pits**

Not applicable.

PS5.8 **Adjacent Occupied Areas**

The Contractor shall organise the work to cause the least possible inconvenience to Mogale CityLM and to the property owners adjacent to or affected by the work. The contractor shall exercise the greatest care to avoid unnecessary damage to trees, gardens, fences, wall and structures on public and private property, and also strictly supervise the behaviour of his workmen. The material resulting from any demolition of existing structures shall be the property of the owner.

Each individual work area will be pre- determined and barricaded or cordoned off as to ensure minimal disruption of traffic flow and inconvenience to the residents

Work in the proximity of the Provincial Roads

The contractors must take due care and exercise caution when working in the vicinity of the provincial road and all requirements and precautions stated in the Wayleave must strictly be adhered to. No plant may be parked, or structures erected within 30m of the Provincial Road. Notice to all relevant Provincial Authorities and arrangements with them shall be the full responsibility of the contractor and is deemed to be included in the rates tendered.

PS5.9 **Blasting operations and requirements**

Municipality 1		Municipality 2		Contractor	
----------------	--	----------------	--	------------	--

SCOPE OF WORKS

Not applicable

PS5.10 **Beacons & Pegs**

The Contractor's attention is drawn to SABS 1200 A Clause 5.1.2 - Preservation and Replacement of Pegs subject to Land Survey Act - and to the liabilities of the Employer and the Contractor in this regard.

The Contractor shall locate and mark all existing pegs for the whole site. Pegs can be encountered all over the site.

The Contractor shall be held responsible for the maintenance of all the cadastral and bench mark pegs on the site that are recorded as existing at the commencement of construction, and for the placement of any pegs that are found to be missing or disturbed upon the completion of the contract.

PS5.11 **Surveying**

Not required, work to be measured with Mogale City Representative for payments>

PS6 **AS-BUILT DRAWINGS**

The Contractor shall provide the Engineer with "As Built" drawings if required.

Only figured dimensions shall be used and drawings shall not be scaled unless required by the Engineer. The Engineer will provide the dimensions that may have been omitted from the Drawings.

PS7 **SAMPLES**

Materials or work that does not conform to the approved samples, submitted in terms of Subclause 26(4) of the General Conditions of Contract, will be rejected. The Engineer reserves the right to submit samples to tests to ensure that the material represented by the sample meets the specification requirements.

PS8 **NOTICES, SIGNS, BARRICADES AND ADVERTISEMENTS**

Notices, signs and barricades, erected in terms of Clause 31 of the General Conditions of Contract, as well as advertisements may be used only if approved by the Engineer. The Contractor shall be responsible for their supply, erection, maintenance and ultimate removal and shall make provision for this in his tendered rates.

The Engineer has the right to have any sign, notice or advertisement moved to another position or to have it removed from the Site of the Works should it in any way prove to be unsatisfactory, inconvenient or dangerous to the general public.

The standard name-board of the South African Association of Consulting Engineers is specified, the cost of which shall be included in the rates tendered for items PSA 8.3.1 and PSA 8.3.2 of Section 1200 A.

PS 9 **WORKMANSHIP AND QUALITY CONTROL**

The onus to produce work that conforms in quality and accuracy of detail to the requirements of the Specifications and Drawings rests with the Contractor, and the Contractor shall, at his own expense,

Municipality 1		Municipality 2		Contractor	
----------------	--	----------------	--	------------	--

SCOPE OF WORKS

institute a quality-control system and provide experienced Engineers, foremen, surveyors, materials technicians, other technicians and technical staff, together with all transport, instruments and equipment to ensure adequate supervision and positive control of the Works at all times.

The cost of supervision and process control, including testing carried out by the Contractor, will be deemed to be included in the rates tendered for the related items of work.

The Contractor's attention is drawn to the provisions of the various Standardised Specifications regarding the minimum frequency of testing that may be required. The Contractor shall, at his own discretion, increase this frequency where necessary to ensure adequate control. [Also refer to GCC 2015 Clause 7](#)

On completion and submission of every part of the work to the Engineer for examination, the Contractor shall furnish the Engineer with the results of the relevant tests, measurements and levels to indicate compliance with the Specifications.

PS10 **SPOIL MATERIAL & STOCKPILE MATERIAL**

No indiscriminate spoiling of material is permitted. Surplus or unsuitable materials shall be spoiled or stockpiled at a site approved by the Engineer. Spoiling shall comply with the applicable statutory and municipal regulations.

Stockpiled material shall be classified and stockpiled on different heaps – for use as bedding, backfill or different road layerworks. Special care shall be taken to stockpile material and the selective use thereafter. On this contract the selection and care shall be deemed to form part of the tendered rate for earthworks.

PS11 **TRENCHES**

Trenches and excavations shall not be left open at all during the builders' holidays or for a period more than 48 hours at any time. The careful guarding to maintain as is subsoil moisture conditions shall be an integral basis of this contract. If for any reason trenches have to be left open, hard barricading as approved by the Engineer with 24 hours site security must be provided. All of the above is deemed to be included in the rates as tendered.

PS12 **TRANSPORT OF MATERIAL**

All costs for transporting materials, including 5km freehaul, shall be included in the applicable tendered rates. All references in the Specifications to transport, overhaul and haul distances shall be deleted irrespective of whether or not the deletion is included in these Project Specifications. Where material must be spoiled at Municipal dumping site or similar, it shall be specifically stated for pricing purposes.

PS12.1 **Approved Transportation Route for Loaded Material**

All costs for transporting materials, including 5km freehaul, shall be included in the applicable tendered rates. All references in the Specifications to transport, overhaul and haul distances shall be deleted

Municipality 1		Municipality 2		Contractor	
----------------	--	----------------	--	------------	--

SCOPE OF WORKS

irrespective of whether or not the deletion is included in these Project Specifications. Where material must be spoiled at Municipal dumping site or similar, it shall be specifically stated for pricing purposes

Where public streets are involved, an approved route for the transportation of loaded material shall be followed. On such route:

- a) Loaded or muddy material falling from tucks on public roads or on completed work shall be removed immediately.
- b) Roads shall be continuously broomed off and cleaned where mud tracking/falling debris occurs

PS13 EMPLOYMENT OF LOCAL LABOUR

PS13.1 General

Due to the specialized nature of the works it is envisaged that the bulk of the works will be done with specialized Construction equipment operated by the Contractor's staff.

Activities which requires hand work or where additional labour is required, the Contractor will be required to make use of local labourers within Mogale City.

A CLO will be appointed where required, for which provision has been made in the

PS13.2 Requirements and activities

Prospective tenderers must take note of the following:

- a) It is required from the Contractor to provide all superintendence, labour, small tools and material for the execution of the works where local labour is involved.
- c) Noise pollution must be kept to the minimum and the work hours will be from Monday to Friday from: 8:00 am to 4:00 pm, and no work will be permitted during public holidays.
- d) The following types of activities have been identified as suitable for unskilled local labour on this project:
 - Cleaning of road surfaces and removal of debris.
 - Day works for other activities, labour not specified elsewhere

Brick works for storm water outlets/inlets and walls, inclusive of foundations for walls and other structures

PS13.3 Wages

All local labour shall be paid according to the latest EPWP labour rate guideline i.e the minimum wage for a local labourer is **R186,00 per day** at a general worker's rate; **R256,00 per day** for a Semi-skilled

Municipality 1		Municipality 2		Contractor	
----------------	--	----------------	--	------------	--

SCOPE OF WORKS

person and a CLO to be remunerated at: **R 6,160 per month** (inclusive of cellphone allowance).

It will be expected from the Tenderers to give a detailed breakdown/explanation of the basis on which labour-based rates have been calculated. This is necessary to enable the Client to make the necessary "rate-adjustments" should minimum wages be changed, via Government legislation, during the course of this Tender.

The contractor is required to keep detailed records of employment for each task-based worker and experience of each work will be entered into a log book and monthly EPWP reports to be submitted to the client.

.

PS13.4 **Liaison with local communities**

The Contractor is to liaise with the local community with regard to local labour to be employed. Mogale City Local Municipality will advise on procedures to be followed

PS13.5 **Skills Related Training**

Not applicable

PS13.6 **Utilization of workers**

- a) The Contractor shall, in so far as it is reasonably feasible taking due cognizance of the nature of the works to be executed at any given time, utilize trained workers on those aspects of the works for which they have been trained.

PS13.7 **Labour-based Schedules**

The following guidelines are available to the prospective tenderers from the Department of Public works:

- Broad Guidelines for the Selection Criteria for Employment
- Guidelines for Task Based Payment Services and Conditions of Employment

33

PS14 **REFERENCES IN SCHEDULE OF QUANTITIES**

PS14.1 **Use of mechanical plant**

The Contractor shall be deemed to have established before tendering the extent to which mechanical plant can be used on the Contract.

Authority to use mechanical plant will not be unreasonably withheld but if it is considered that circumstances are such that the use of plant shall be suspended temporarily or permanently, the relevant construction procedure shall be modified at the Constructor's cost and the Contractor shall be deemed to have no cause for claim against MOGALE CITY LOCAL MUNICIPALITY on account of having to continue the work by another method or if any order issued in terms of this Clause results in the mechanical plant having to stand idle for any period or having to be removed.

Municipality 1		Municipality 2		Contractor	
----------------	--	----------------	--	------------	--

SCOPE OF WORKS

Where, due to proximity or any danger to existing structures or services, it is considered advisable to excavate by hand methods; it shall be deemed reasonable for the purpose of this Clause for authority to use mechanical plant to be withheld.

PS15. **RATES ALL INCLUSIVE**

The tendered rates must allow for all direct and indirect costs required for the provision and/or instruction of the items as listed in the Schedule of Quantities as no additional payments will be considered.

PS15.1 **Payment for day works labour**

Where payment for skilled or semi-skilled labour is claimed under day work items proof of such skills shall be submitted.

PS16. **ESCALATION**

General Escalation is only applicable to contracts of 12 months and longer.

Escalation for Special Materials will be applicable on this contract. Calculations will be done in accordance with Clause 6.8 of General Conditions of Contract 2015. Refer to Contract Data for more details.

PS17 **ACCOMMODATION OF TRAFFIC (REFER TO ANNEXURES FOR DETAILS)**

The Contractor must allow for the accommodation of traffic under the items allowed for in the Schedule of Quantities. These rates to allow for any temporarily bridges, safety measures at excavations, traffic signs as required by the Safety Regulations, etc.

PS18 **EARTHWORKS**

The tenderers are referred to Clause 3.6.3. in the next Section (Project Specifications) regarding freehaul and overhaul.

PS19 **OCCUPATIONAL HEALTH & SAFETY ACT**

The Employer and Contractor hereby agree, in terms of the provisions of Section 37(2) of the Occupational Health and Safety Act No.85 of 1993, hereinafter referred to as "the Act", that the contractor as an employer in its own right and in its capacity as contractor for the execution of the works, shall have certain obligations and that the following arrangement shall apply between them to ensure compliance by the contractor with provisions of the Act, namely:

1. The contractor undertakes to acquaint the appropriate officials and the employees of the contractor with all relevant provisions of the Act, and the regulation promulgated in terms of the Act, and

Municipality 1		Municipality 2		Contractor	
----------------	--	----------------	--	------------	--

SCOPE OF WORKS

- 2. The contractor undertakes that all relevant duties, obligations and prohibitions imposed in terms of the Act and regulations will be fully complied with, and
- 3. The contractor hereby accepts sole responsibility for such due compliance with the relevant duties, obligations and prohibitions imposed by the Act and regulations and expressly absolves the employer and the employer’s consulting engineers from being obliged to comply with any of the aforesaid duties, obligations and prohibitions in respect of the work included in the contract.

The contractor shall be obliged to report forthwith to the employer any investigation, complaint or criminal charge which may arise as a consequence of the provisions of the Act and regulations pursuant to work performed on behalf of the employer, and shall, on written demand, provide full details in writing of such investigation, complaint or criminal charges.

A checklist of all Health & Safety Activities that may be required on site is included. The Tenderer is expected to implement all of the requirements as listed. Allowance is made in the P&G’s Section of the Schedule of Quantities (fixed and time related) to price all of the required safety measures to be executed and formalized on site.

The Contractor shall complete the “Agreement Form B1.” included in Part 4 of the Contract and therein designate in writing the name of the responsible person required in terms of the General Safety Regulations R11 sub clause 1.

Municipality 1		Municipality 2		Contractor	
----------------	--	----------------	--	------------	--

SCOPE OF WORKS

PS20 APPLICABLE STANDARDISED SPECIFICATIONS & REGULATIONS

For the purposes of this Contract, the following shall apply:

- SABS 1200 Standardized Specifications for Civil Engineering Construction
- COLTO Standard Specifications for Road and Bridge Works for State Road Authorities.
- Sabita Manual 6

All particular specifications for work not covered by the SABS 1200 Standardised Specifications are also bound in Portion 3 of the Project Specifications:

REGULATIONS

The Contractor shall conform in all respects to the requirements contained in regulations by higher authorities. Such regulations shall include inter alia:

- 01) National Building Regulations.
- 02) Code of Practice for the Wiring of Premises, SABS 0142-1981 as amended.
- 03) The Mines and Works Regulations, Government Notice Number R1609 of 1962-09-28, as amended.
- 04) The Occupational, Health and Safety Act 85/93, as amended.
- 05) The local Municipal Bye-laws and Regulations as well as the regulations of the local Supply Authority.
- 06) The local Fire Regulations.
- 07) The regulations of Telkom.
- 08) The regulations of the local Gas Board where applicable.
- 09) The standard regulations of any Government Department or public service company where applicable.
- 10) The Regulations of Rand Water.
- 11) The Regulations of Eskom
- 12) The NHBRC (*National Home Builders Registration Council*) Building code: Volume 1, 2 & 3.

The Contractor shall pay and indemnify the Employer against any fees or charges by law and shall keep the Employer and the Engineer indemnified against all penalties and liabilities of any kind for breach by the Contractor or any of the conditions due by law, except insofar as amended or specifically allowed by the Engineer.

Municipality 1		Municipality 2		Contractor	
----------------	--	----------------	--	------------	--

PS21 **STATUS**

In event of disputes and/or discrepancies the different documentation will have the following status in order or precedence:

- i.contract agreement;
- ii.form of tender and appendix to form of tender;
- iii.special conditions of tender;
- iv.project specification;
- v.general conditions of tender;
- vi.particular specifications;
- vii.schedule of quantity and summary;
- viii.statutory regulations;
- ix.standard COLTO specifications;
- x.standard SABS specifications
- xi.any other standard specification

Municipality 1		Municipality 2		Contractor	
----------------	--	----------------	--	------------	--

PART 2 : PROJECT SPECIFICATION

C3.6.2 PART 2

VARIATIONS AND ADDITIONS TO THE STANDARDISED SPECIFICATIONS FOR THIS CONTRACT, AND PARTICULAR SPECIFICATIONS

The following variations and additions to the COLTO Specifications referred to in the last clause of Portion 1 apply to this Contract.

SECTION 1100: DEFINITIONS AND TERMS

B1115 GENERAL CONDITIONS OF CONTRACT

Replace Clause 1115 with the following:

The General Conditions applicable to this Contract are the General Conditions of Contract for Construction Works, 2015, Third Edition, (GCC 2015)

The General Conditions applicable to this Contract are the General Conditions of Contract for Construction Works, 2015, Third Edition, (GCC 2015).

Accordingly, all reference in the Standard Specifications to any other General Conditions of Contract (GCC) has to be amended. The Standard Specifications have been scrutinized and clauses, which refer to another GCC, identified. These are tabulated below together with the relevant equivalent clause in the GCC 2015 Conditions of Contract. The context of the reference to the GCC is also noted.

Whereas every effort has been made to include all of the affected clauses in the table, there may be some omissions. In every case, however, the GCC 2015 Conditions of Contract for Construction, as amended by the Special Conditions in Section C1.2 of this Volume, shall apply and the contractor shall be responsible for interpretation of the equivalent clause.

Municipality 1		Municipality 2		Contractor	
----------------	--	----------------	--	------------	--

CHANGES TO ALL REFERENCES BY THE COLTO STANDARD SPECIFICATIONS TO THE COLTO GENERAL CONDITIONS OF CONTRACT AND 2015 GENERAL CONDITIONS (GCC2015)

COLTO Standard Specification		GCC2010 General Conditions of Contract for Construction Works, 2010, 2 nd Edition		GCC2015 General Conditions of Contract for Construction Works, 2015, 2 nd Edition	
Clause No	Page No	Cl. No	Description or Reference	Cl. No	Description or Reference
1115	1100-2		Definition of GCC2010		Definition of GCC2015
1204	1200-2	8.3.1	Construction Programme	5.6.1	Construction Programme
1204	1200-2		Applicable to FIDIC		
1206	1200-3		Setting out of works	5.4	
1209(a)	1200-4		Applicable to FIDIC		GCC 2015 as applicable
1209(e)	1200-5	14.5	Plant and material intended for use in works		
1210	1200-5	10.1	Taking- over certificate	5.14.	Certificate of Practical Completion
1212(1)	1200-7	13.8	CPA on alternative designs		
1215	1200-9	5.12	Extension of time for Practical completion.	5.12	Extension of time for Practical completion
1217	1200-10	8.2	Care of the works	8.2	
1303(ii)	1300-1		Applicable to FIDIC		
1303(iii))	1300-1	13.7 & 13.8	Price adjustment Item 13.01 (a)	6.11	
1303(iii))	1300-2	13.7 & 13.8	Price adjustment Item 13.01 (b)		
1303 (iii)	1300-1		Not applicable to this contract		Not applicable to this contract

SECTION 1300: GENERAL REQUIREMENTS AND PROVISIONS**B1303 PAYMENT**

Add the following:

With the bulk of the works being done on an as-and-when required basis, a maximum allowance for General obligations will be 12% per works order received as indicated in the Bill of Quantities under item 1300.

Municipality 1		Municipality 2		Contractor	
----------------	--	----------------	--	------------	--

SECTION 1500: ACCOMMODATION OF TRAFFIC

B1517 MEASUREMENT AND PAYMENT

Add the following payment items:

The Contractor’s obligation under this Section 1500 shall be measured for payment according to the traffic accommodation along the route/road where the traffic is handled.

Primary (P)	–	Multi Lanes
Secondary (S)	–	Single Lane
Secondary (S)	–	Multi Lane
Main Tertiary (T)	–	Single Lane
Tertiary (t)	–	Single Lane

The bulk of the works to be performed will be on residential streets, with lower traffic speeds and volumes, compared to highways, thus requiring less stringent measures related to traffic control.

For single lane roads traffic accommodation will only be applicable once, for instance where works are carried out in half widths, the Contractor will only be permitted to claim once off for the traffic accommodation over the length of road and nor for recurring visits to complete the other remaining half width.

For Primary and Secondary Multi Lane roads the Contractor traffic accommodation will be applicable twice, for instance once, where the North bound lane is done and again when the South Bound lane is done.

Item	Unit
B15.01 Accommodating traffic and maintaining temporary Deviations along the following routes/roads	
(a) Primary (P) – Multi Lanes	Km
(b) Secondary (S) – Multi/ Single Lanes	Km
(c) Main Tertiary (T) – Single Lane	Km
(d) Tertiary (t) – Single Lane	Km

SECTION 1600: OVERHAUL

B1601 SCOPE

Add the following to Clause 1601:

“No overhaul will be paid to the contractor for transporting any materials whatsoever, whether obtained from commercial sources, designated borrow areas or any other source of material. No overhaul will be paid for any spoil material to stockpiled areas selected by the Employer when so directed by the Engineer. The cost of transporting all such materials must be included in the relevant payment items for work involved, notwithstanding anything to the contrary in any other payment item.”

SECTION B1800: DAYWORKS

Municipality 1		Municipality 2		Contractor	
----------------	--	----------------	--	------------	--

Add the following section to the standard specifications:

Section B1800: Dayworks

Contents

- B1801 Scope
- B1802 General Requirements
- B1803 Measurement and payment

B1801 SCOPE

This section covers the listing of daywork items in accordance with the General Conditions of Contract clause 6.5, for the use in determining payment for work which cannot be qualified in specific units in the schedule of quantities, or work ordered by the engineer during the construction period which was not foreseen at tender stage and for which no applicable rate exists in the schedule of quantities. Prescribed Labour Rates will also form part of dayworks.

B1802 GENERAL REQUIREMENTS

Work will be classified as day work only if the Engineer considers no other rate in the Bill of Quantities appropriate for payment purposes.

An instruction regarding all work to be carried out under daywork in terms of Clause 6.5 of the General Conditions of Contract will be issued at the discretion of the Engineer. Some or all of the items priced under daywork in the Bill of Quantities may possibly not be required for this Contract.

The Contractor and the Engineer will agree on the method of recording the working hours prior to the commencement of the work. Any long period of idling at any one time which in the opinion of the Engineer or his representative is beyond that required for normal operating conditions will not be paid for as working time. Non-working hours for any reason shall not be measured for payment.

SECTION B1900: CONSTRUCTION PLANT, EQUIPMENT AND METHODS

Add the following section to the standard specifications:

Section B1900: Construction Plant, Equipment and method

Contents

- B1901 Scope
- B1902 General Requirements
- B1903 Measurement and payment

B1801 SCOPE

This section covers the Construction Plant, Equipment and methods to be used for the placing of materials and repair works in accordance with the General Conditions of Contract clause 7.2 & 4.9.1.

B1902 GENERAL REQUIREMENTS

For Preparatory works and materials to be placed on the road surface, suitable Construction Plant and Equipment as indicated below are to be used:

Asphalt Surfacing / overlays:

Asphalt Paver; 1 Ton Smooth Drum Vibratory Roller, Rubber Wheel rollers, Mechanical brooms

Prime Spay

Single Seals:

Municipality 1		Municipality 2		Contractor	
----------------	--	----------------	--	------------	--

Chip Spreader, Rubber wheel roller, Mechanical brooms, Spray truck/ tanker for tack coat

Slurry Surfacing:

Slurry truck, capable of storing and mixing the crusher sand/dust, emulsions and additives internally, before applying the Slurry mixture onto the road surface with a box/ bar to the required thicknesses. A Concrete mixer may not be used as alternative. The box/spray bar must be adjustable to a maximum width of 3,7m.

Smaller areas (bellmouths) , etc can be completed by hand.

Patching:

Compressors, wackers/rammers, jack hammers and breakers are to be used for the excavation and preparatory works.

Milling:

A milling machine capable of milling up to 1.5m wide is required for milling works.

B1903 MEASUREMENT AND PAYMENT

No additional pay items, other than specified in the Bill of Quantities for the placing of materials will be applicable as per clause COLTO, clause 1209 (c)(ii).

No additional pay items, other than specified in the Bill of Quantities for Construction Plant will be applicable.

SECTION 2200: DRAINAGE

B2201 Scope

The repair and reinstatement of storm water Manholes, kerb inlets (catchpits) and pipes, when required

B22.03: MEASUREMENT AND PAYMENT

• **Repair / reinstatement of Storm water pipes:**

The unit rates tendered per linear meter, for storm water pipes to be all inclusive for materials, labour and any other costs to excavate, or replace or construct new storm water pipes, including required backfilling and excavations up to a maximum depth of 2metres.

• **Repair / reinstatement of Manholes:**

The unit rates tendered per linear meter, for manholes, to be all inclusive for materials, labour and any other costs to excavate, or construct a new storm water manholepipes, including required backfilling and excavations up to a maximum depth of 2 metres.The extra over rate will be applicable for manholes deeper than 2metres.

• **Repair / reinstatement of Storm water structures (catchpits) and accessories:**

The Rates provide for each item to be all inclusive for materials, labour and any other costs to construct, cast or source the required items, including backfilling and excavating

No additional pay items, other than specified in the Bill of Quantities under Drainage will be applicable.

Municipality 1		Municipality 2		Contractor	
----------------	--	----------------	--	------------	--

SECTION 2300: CONCRETE KERBS

B2301 Scope

The repair and reinstatement of concrete kerbs, when required

B23.01: MEASUREMENT AND PAYMENT

The unit rates tendered are per linear meter, will be for the various types of kerbs, all-inclusive to place or replace existing / new kerbs.

No additional pay items, other than specified in the Bill of Quantities under Drainage will be applicable.

SECTION 3200: SELECTION, STOCKPILING AND BREAKING DOWN OF MATERIAL FROM BORROW PITS, CUTTINGS AND EXISTING PAVEMENT LAYERS AND PLACING AND COMPACTING THE GRAVEL LAYERS

Add the following to Clause 3202:

Prior to placing any materials, the Contractor shall submit indicator test results representative of the material source to the Engineer to prove the suitability of the proposed material for its intended purpose. No payment will be made for material placed without the prior written approval of the Engineer.

Add the following to Clause 3212:

No additional payment will be made for stockpiling or additional handling required for any materials. Any such stockpiling or additional handling or double handling costs will be deemed to be included in the tendered rates for the relevant items.

SECTION 3800: BREAKING UP EXISTING PAVEMENT LAYERS.

B3807 MEASUREMENT AND PAYMENT

Add the following:

Item	Description
B38.16	Fine milling to improve skid resistance or to remove rutting and unevenness (max 40mm deep) _____m ² . The unit measurement shall be the square meter of surface treated. The tendered rate shall include for compensation for all additional measurements, adjustments and costs to treat the area required, level control, cross milling where required also to ensure a free drained area when complete.

SECTION 4200: ASPHALT BASE AND SURFACING

B4201 SCOPE

Add the following:

- “The asphalt surfacing mix to be constructed on this project shall either be:
- A medium continuously graded asphalt with a penetration grade binder
- or.

Municipality 1		Municipality 2		Contractor	
----------------	--	----------------	--	------------	--

- A Semi-gap grade asphalt – Type AP1 or similar as per typical design included under item B4203 below.

B4202 MATERIALS

(a) Bituminous binders

(h) Conventional binders

Add the following:

“The bitumen used in the asphalt surfacing shall be a 40/50 penetration road grade bitumen.

The base bitumen shall comply with SABS 307 – 1972 Amendment 6, 2002.

The contractor shall obtain approval regarding the supplier of asphalt before any work is executed (or orders placed). The contractor will have the Asphalt tested for minimum requirements

(b) Aggregates

Add the following paragraph after the introductory paragraph:

“The use of run of crusher type materials shall not be permitted. Asphalt mixes shall be manufactured using individual single-size coarse aggregates fractions and crushed fine aggregates blended to conform to the specified grading requirements.”

(v) Absorption

Add the following:

“When tested in accordance with **TMH1** method C4 the total binder absorption of the combined coarse and fine aggregate blend shall not exceed 0,5%.”

(vi) Sand equivalent

Add the following:

“No natural sand may be used in asphalt mixes without the written permission of the Engineer. The natural sand shall then comply with the requirements of SABS 1083 and Section 4202(b) of the Standard Specifications and shall have minimum sand equivalent value of 50 when tested in accordance with **TMH 1 method B19**. If permitted by the engineer, the permissible quantity of natural sand shall not exceed 5% by mass of the combined aggregate in the approved working mix. The Contractor shall submit full details regarding the exact quantity and quality of the natural sand he proposes to use in the asphalt mix which the engineer will then consider.”

(viii) Grading

Add the following paragraphs:

“The grading limits for the combined aggregate grading for the asphalt surfacing shall be as specified in table 4204/7: Continuously graded – medium graded.”

In addition to the specified grading limits, the percentage, by mass, of aggregate smaller than 0,005mm, determined in accordance with THM 1 Method A6, shall be less than 1,0% of the combined aggregates excluding the active filler added.

The engineer may request a reconsideration of blends to achieve any grading within the relevant envelope in order to improve certain properties.

Municipality 1		Municipality 2		Contractor	
----------------	--	----------------	--	------------	--

(c) Fillers

Add the following after the last paragraph:

“The contractor will be required to add 1% by mass active filler in the form of hydrated lime.”

(h) General

Add the following after the second paragraph:

“Aggregates used in the approved production mix shall only be taken from stockpiles that are sufficient in size for the production of a minimum of two days work and shall have been tested for conformance and uniformity. The test results shall be presented to the engineer.

The stockpiles shall be covered with plastic sheeting in order to keep the material dry in the event of rain.”

B4203: COMPOSITION OF ASPHALT BASE AND SURFACING MIXTURES

In the first paragraph, third last line, after “or active filler”, add “or aggregate content”

Add the following after the first paragraph:

“The Contractor shall allow sufficient time in his programme for testing by external laboratories. The approval of the proposed mix design from the source shall be agreed with the engineer. The contractor shall only order asphalt once the mix design has been approved”.

Delete the fifth paragraph and replace with the following:

“The design of the asphalt mix shall be tested in accordance with “Interim Guidelines for the Design of Hot Mix Asphalt in South Africa (June 2001)”, and appropriate research developments.

The engineer shall make a final selection of binder content based on the results and the compactability of the mix for its application in the works.

The Contractor shall include the cost of the specified approval process in the price of the asphalt. The cost of testing shall be included in the different rehabilitation measures.

The Contractor shall also allow for the approval process in his construction programme.”

(a) Asphalt base and surfacing layers

The relevant asphalt mixes for the base and surfacing layers shall satisfy the requirements in table B4203/1.

For the Continuous graded asphalt – Type AP1, a typical design specification has been provided on the next page.

TABLE B4203/1: ASPHALT MIX REQUIREMENTS: SURFACING

Property	Unit	Continuous graded Surfacing mixes
Marshall Stability	kN	8 – 18
Marshall flow	mm	2 – 6
Stability/Flow	kN/mm	2,5 (min)
VMA	%	15 (min)
VFB	%	65 – 75
Air voids	%	3 – 5
Indirect tensile strength @ 25°C	kPa	> 1000 (min)
Dynamic Creep Modules @ 40°C	MPa	20 (min)

Municipality 1		Municipality 2		Contractor	
----------------	--	----------------	--	------------	--

MOGALE CITY LOCAL MUNICIPALITY

TENDER NO: PWRT (R&T) xx/2021 REHABILITATION AND RESURFACING OF ROADS ON AS PER THE ANNUAL ROADS PROJECT PLANS OVER A PERIOD OF 36 MONTHS

PROJ SPEC PART 2

Modified Lottmann	TSR	0,8 (min)
Air permeability @ 7% voids	cm ²	1 x 10 ⁻⁸
Binder film thickness	.001mm	5,5 – 8,0
Filler/bitumen ratio	-	1,0 – 1,5
Water permeability measured on 100mm cores from trial section. (AAPT test 98)	X 10 ⁻⁵ cm/s	Report*

Municipality 1		Municipality 2		Contractor	
----------------	--	----------------	--	------------	--

MOGALE CITY LOCAL MUNICIPALITY
 TENDER NO: PWRT (R&T) xx/2021 REHABILITATION AND RESURFACING OF ROADS ON AS PER THE ANNUAL ROADS
 PROJECT PLANS OVER A PERIOD OF 36 MONTHS
 PROJ SPEC PART 2

TYPICAL DESIGN – TYPE AP1 CONTINUOUS GRADED APHALT: SURFACING

Aggregate / Aggregaat										Binder / Bindmiddel																																																																																																																										
Sample / Monitor No.	Nom. Size / Groottes	Type and Source / Tipe en Bron								Type / Tipe	AD-1	Source / Bron	Colls																																																																																																																							
1	13.2 mm	PPC Leucorite Angularite								Pen @ 25°C (0.1 mm)	33	Visc @ 60°C (Pas)																																																																																																																								
2	9.5 mm	Witman Silenrol Afvalste								Soft / Sag at 1°C	8x.6	Visc @ 100°C (Pas)	0.51																																																																																																																							
3	6.7 mm	Witman Silenrol Afvalste								RD	1.029	Elastic Recovery @ 15°C (P)	56																																																																																																																							
4	Crusher Dust	Witman Silenrol Afvalste								Temp. (Mts/Meng) (°C)	185	Temp. (Comp. Verdig.) (°C)	140°C																																																																																																																							
5	W/Crusher Sand	Roadstone Washed Crusher Sand																																																																																																																																		
6	BA.F	Roadpoint Screened Fine RAP																																																																																																																																		
7	Filer	Plant Filer																																																																																																																																		
NOTE: Test Methods Refer To TMI 1 3 SABS 1										Bulk Relative Density			Marshall Stability & ITS	Voids in Aggregate																																																																																																																						
NOTE: Test Methods Refer To TMI 1 3 SABS 1										Air Voids in mix			Marshall Flow and Creep	Voids Filled with binder																																																																																																																						
Sieve Analysis / Sifanalise (B.4) - % Passing Sieves / % Deur Sifles										Design / Ontwerp																																																																																																																										
Sample No. / Monitor No.	1	2	3	4	5	6	7	Mix / Mengsel	Spec. / Spes.																																																																																																																											
% in Mix / Mengsel	15%	14%	10%	29%	10%	10%	1%																																																																																																																													
Sieve Size (mm)	37.5	47.5	60	75	95	119	150																																																																																																																													
Silicite (mm)	19.0	100	100	100	100	100	100	100	100	100-100																																																																																																																										
	13.2	87	100	100	100	100	100	100	100	54-100																																																																																																																										
	9.5	29	90	100	100	100	93	100	97	75-92																																																																																																																										
	6.7	7	75	88	100	100	78	100	99	60-91																																																																																																																										
	4.75	1	2	26	96	98	65	100	59	50-70																																																																																																																										
	2.36	1	1	5	81	77	49	100	46	37-55																																																																																																																										
	0.85	1	1	3	28	27	37	100	30	25-41																																																																																																																										
0.600	1	1	3	37	31	28	100	22	16-28																																																																																																																											
0.300	1	1	2	25	17	20	100	15	12-20																																																																																																																											
0.150	0	1	2	17	8	13	100	10	6-15																																																																																																																											
0.075	0	1	1.8	12.3	3.2	2.7	97.6	0.5	4-10																																																																																																																											
BSD	(B14-15)	2.90	2.89	2.89	2.89	2.89	2.75	2.89	2.90																																																																																																																											
Sand eq. Wt.	(B16)								6.5																																																																																																																											
Water absorp.	(B14-15)	0.30	0.40	0.60	0.46	0.20																																																																																																																														
ACV / AWW	(B1)																																																																																																																																			
10% F.A.C.T / F.A.W.V	(B1)																																																																																																																																			
Flak. Index / Patch Index	(B3)	24.50	19.20	26.70																																																																																																																																
PSV / SPW	(B4)																																																																																																																																			
ADV / AMV	1 1																																																																																																																																			
Sieve analysis / Sifanalise										Design / Ontwerp																																																																																																																										
										<table border="1"> <thead> <tr> <th>Binder / Bindmiddel (%)</th> <th>4.2</th> <th>4.5</th> <th>4.8</th> <th>5.1</th> <th>Proven / Vervul</th> <th>Specification</th> </tr> </thead> <tbody> <tr> <td>Max. / Maks. TBC (Flow)</td> <td>2.964</td> <td>2.966</td> <td>2.969</td> <td>2.972</td> <td></td> <td>2.975</td> </tr> <tr> <td>BSD (Marshall)</td> <td>2.952</td> <td>2.955</td> <td>2.958</td> <td>2.960</td> <td></td> <td>2.966</td> </tr> <tr> <td>Voids in Mix / Ruimtes in Mengsel (%)</td> <td>5.3</td> <td>4.8</td> <td>3.6</td> <td>2.9</td> <td></td> <td>4.9</td> </tr> <tr> <td>Stab. (Marshall) (kN)</td> <td>14.1</td> <td>12.8</td> <td>11.5</td> <td>9.9</td> <td></td> <td>11.9</td> </tr> <tr> <td>Flow / Vloe (Marshall) (mm)</td> <td>4.9</td> <td>4.7</td> <td>4.6</td> <td>4.9</td> <td></td> <td>4.6</td> </tr> <tr> <td>Stab./Flow Ratio / Stab./Vloe Verh.</td> <td>2.9</td> <td>3.7</td> <td>3.5</td> <td>3.0</td> <td></td> <td>2.90</td> </tr> <tr> <td>ITS (kPa)</td> <td>110.0</td> <td>117.0</td> <td>115.0</td> <td>103.0</td> <td></td> <td>110.1</td> </tr> <tr> <td>Creep / Krimp (Dynamic / Static) (mm)</td> <td></td> <td></td> <td></td> <td></td> <td></td> <td>20.5</td> </tr> <tr> <td>Air Perm. / Lugtoelatingeveld</td> <td></td> <td></td> <td></td> <td></td> <td></td> <td>< 1x10¹⁰</td> </tr> <tr> <td>VMA / RMA (%)</td> <td>14.8%</td> <td>14.5%</td> <td>14.0%</td> <td>14.7%</td> <td></td> <td>14.0%</td> </tr> <tr> <td>VTD / RGD (%)</td> <td>64%</td> <td>66%</td> <td>74%</td> <td>80%</td> <td></td> <td>72%</td> </tr> <tr> <td>MMI.5 (mm)</td> <td></td> <td></td> <td></td> <td></td> <td></td> <td></td> </tr> <tr> <td>Absorp. (Binder/Bindmiddel) (%)</td> <td>0.5%</td> <td>0.5%</td> <td>0.5%</td> <td>0.4%</td> <td></td> <td>0.5%</td> </tr> <tr> <td>Film Thickness (µm)</td> <td>7.1</td> <td>7.8</td> <td>8.2</td> <td>8.7</td> <td></td> <td>8.0</td> </tr> <tr> <td>Optional Voids @ 300 g/m² stone (%)</td> <td></td> <td></td> <td></td> <td></td> <td></td> <td>3.2%</td> </tr> <tr> <td>Modified Lotman</td> <td></td> <td></td> <td></td> <td></td> <td></td> <td>> 0.6</td> </tr> </tbody> </table>				Binder / Bindmiddel (%)	4.2	4.5	4.8	5.1	Proven / Vervul	Specification	Max. / Maks. TBC (Flow)	2.964	2.966	2.969	2.972		2.975	BSD (Marshall)	2.952	2.955	2.958	2.960		2.966	Voids in Mix / Ruimtes in Mengsel (%)	5.3	4.8	3.6	2.9		4.9	Stab. (Marshall) (kN)	14.1	12.8	11.5	9.9		11.9	Flow / Vloe (Marshall) (mm)	4.9	4.7	4.6	4.9		4.6	Stab./Flow Ratio / Stab./Vloe Verh.	2.9	3.7	3.5	3.0		2.90	ITS (kPa)	110.0	117.0	115.0	103.0		110.1	Creep / Krimp (Dynamic / Static) (mm)						20.5	Air Perm. / Lugtoelatingeveld						< 1x10 ¹⁰	VMA / RMA (%)	14.8%	14.5%	14.0%	14.7%		14.0%	VTD / RGD (%)	64%	66%	74%	80%		72%	MMI.5 (mm)							Absorp. (Binder/Bindmiddel) (%)	0.5%	0.5%	0.5%	0.4%		0.5%	Film Thickness (µm)	7.1	7.8	8.2	8.7		8.0	Optional Voids @ 300 g/m ² stone (%)						3.2%	Modified Lotman						> 0.6
Binder / Bindmiddel (%)	4.2	4.5	4.8	5.1	Proven / Vervul	Specification																																																																																																																														
Max. / Maks. TBC (Flow)	2.964	2.966	2.969	2.972		2.975																																																																																																																														
BSD (Marshall)	2.952	2.955	2.958	2.960		2.966																																																																																																																														
Voids in Mix / Ruimtes in Mengsel (%)	5.3	4.8	3.6	2.9		4.9																																																																																																																														
Stab. (Marshall) (kN)	14.1	12.8	11.5	9.9		11.9																																																																																																																														
Flow / Vloe (Marshall) (mm)	4.9	4.7	4.6	4.9		4.6																																																																																																																														
Stab./Flow Ratio / Stab./Vloe Verh.	2.9	3.7	3.5	3.0		2.90																																																																																																																														
ITS (kPa)	110.0	117.0	115.0	103.0		110.1																																																																																																																														
Creep / Krimp (Dynamic / Static) (mm)						20.5																																																																																																																														
Air Perm. / Lugtoelatingeveld						< 1x10 ¹⁰																																																																																																																														
VMA / RMA (%)	14.8%	14.5%	14.0%	14.7%		14.0%																																																																																																																														
VTD / RGD (%)	64%	66%	74%	80%		72%																																																																																																																														
MMI.5 (mm)																																																																																																																																				
Absorp. (Binder/Bindmiddel) (%)	0.5%	0.5%	0.5%	0.4%		0.5%																																																																																																																														
Film Thickness (µm)	7.1	7.8	8.2	8.7		8.0																																																																																																																														
Optional Voids @ 300 g/m ² stone (%)						3.2%																																																																																																																														
Modified Lotman						> 0.6																																																																																																																														
Notes / Notas																																																																																																																																				
Sustained loading on the stone																																																																																																																																				
on stone																																																																																																																																				

Municipality 1	Municipality 2		Contractor
----------------	----------------	--	------------

B4204: PLANT AND EQUIPMENT

(a) General

Add the following paragraph:

“Plant and vehicles used at the paving site shall be free from oil, fuel and hydraulic fluid leaks. Any items of plant or vehicle showing signs of these leaks shall immediately be removed from the site.”

(b) Mixing plant

(i) Conventional binders

Add the following paragraph below the sixth paragraph:

“For drum type mixers, the active filler shall not be added in the cold-feed line of the mixer but a separate feeding pipe shall be installed for feeding the required percentage of lime into the mix at the same position where the binder is fed into the mix.”

B4205: GENERAL LIMITATIONS AND REQUIREMENTS AND THE STOCKPILING OF MIXED MATERIAL:

(a) Weather conditions

Add the following:

“No paving shall be carried out under unstable weather conditions. Should rain or cold weather threaten, all exposed areas shall immediately be reinstated with asphalt and milling operations shall cease.”

(c) Surface requirements

(iii) Tack coat

Add the following:

“A tack coat shall in all instances be applied to the surface to be paved, including all vertical cut edges. The tack coat shall be 30% cationic spray grade bitumen emulsion applied at 0,4 l/m², or as directed by the engineer. The tack coat may not be applied to the excavated area more than four hours before the asphalt is placed.

Hand spraying shall only be allowed on areas approved by the engineer. Efficient spray equipment, capable of spraying an even layer of emulsion covering the whole area to the specified rate, shall be used.”

B4206: PRODUCING AND TRANSPORTING THE MIXTURE

(c) Transporting the mixture

Add the following:

“Special precautions shall be taken by the contractor to ensure that segregation does not occur. Visual inspection will be carried out by the engineer and his staff. Segregated mixes will under no circumstances be accepted by the engineer. Effective steps shall be taken by the contractor to prevent segregation. Trucks with segregated asphalt mixes shall be rejected by the engineer.

Special precautions shall be taken by the contractor to ensure that the temperature of the total mass of asphalt does not decrease by more than 10°C from point of dispatch to the point where it is to be paved. The use of thermal blankets to cover the asphalt is obligatory.”

Municipality 1		Municipality 2		Contractor	
----------------	--	----------------	--	------------	--

B4210: COMPACTION

Add the following to the 4th paragraph:

“An appropriate rolling temperature range will be determined by the contractor and will be submitted to the engineer for approval. This range shall be applied as specification during the contract.”

In the 6th paragraph replace “97 per cent, minus the percentage voids in the approved mix, “ with “94 per cent.”

B4213: CONSTRUCTION TOLERANCES AND FINISH REQUIREMENTS:

(a) **Binder content**

Delete the words “clause 8206 or clause 8305” in the third line and Substitute with “clause B8305”.

B4214: QUALITY OF MATERIALS AND WORKMANSHIP

(a) **Routine inspection and tests**

Replace the second paragraph with:

“Test results and measurements will be assessed in accordance with the provisions of Section 8200 as specified in the project specifications.”

Add the following sub-clause:

“(d) Process control by the contractor

The Contractor shall keep accurate records and submit the following information to the engineer on a daily basis:

- (a) Where every truckload of asphalt is laid (position, lane, time and date).
- (b) The truck number from which control samples have been taken. All samples taken from trucks shall be numbered.
- (c) The temperature of the asphalt in the truck both at the mixing plant and at the paving equipment.”

B4215: MEASUREMENT AND PAYMENT

Item	Unit
B42.04: Tack coat of 30% stable-grade emulsion:	Litre (l)

Add the pay item as follows:

“The tendered rate and unit of measurement shall mutadi mutandis be applicable for the application of a tack coat by means of hand sprayers on written approval by the engineer only.”

Municipality 1		Municipality 2		Contractor	
----------------	--	----------------	--	------------	--

MOGALE CITY LOCAL MUNICIPALITY
TENDER NO: PWRT (R&T) xx/2021: REHABILITATION AND RESURFACING OF ROADS AS PER THE ANNUAL ROADS
PROJECT PLANS OVER A PERIOD OF 36 MONTHS

Item		Unit
“B42.08 100mm cores in asphalt paving		Number (No)
<i>Amend the 1st sentence by adding the following after the word “drilled.”</i>		
<i>“irrespective of depth of core.”</i>		

		Number (No)
For resurfacing of existing road surfaces and new roads construction, items B42.01 & B42.02 will apply		

B42.01	Asphalt base, 4,5 % Bitumen, 35/50 Pen Bitumen).	Ton (t)
(a)	Continuously graded, max 26,5mm aggregate	

B42.02	Asphalt Surfacing (medium),	
(a)	Continuously graded max 13,2mm aggregate (medium grade) 5,0%, 50/70 Pen Bitumen)	Ton (t)
(d)	Continous graded (Type AP-1, TRH 8 , max.19mm aggregate)	Ton (t)

For patching repairs to existing road surfaces, item B42.11 will apply

B42.11	Asphalt constructed for rehabilitation purposes in accordance with the provisions of subsubclause 4213 (f)(ii)	
(a)	Base constructed with new asphalt using a 35/50 Pen Bitumen,4,5% bitumen:	
(i)	Continuously graded – BTB, max 26,5mm aggregate:	
	(i) to various depths	ton (t)
(b)	Surfacing constructed with new asphalt using a 50/70 Pen Bitumen,5% Bitumen:	
(i)	Continuously graded – medium, max 13,2mm aggregate:	
	(i) Max 60mm thickness	ton (t)

After the first paragraph add the following:

“The unit of measure for sub item (a) shall be the ton or square meter of asphalt overlay placed to the thickness specified and measured according to certified weighbridge tickets issued in respect of the mixture used. (Including temporary wedges to longitudinal and transverse joints).
No payment shall be made for excess width and wastage of asphalt, and the mass of such excess or wasted material shall be deducted from the recorded delivery for payment purposes. No payment shall be made for asphalt in excess of the mean spread rate(s), which shall be determined on a daily basis as follows:

$$S = \frac{1000}{A \cdot B} m^3 / ton$$

Where:

- S = Mean spread rate in m²/ton
- A = Average bulk relative density achieved on the road in ton/m³
- B = (specified asphalt thickness in mm) + 5mm”

Municipality 1		Municipality 2		Contractor	
----------------	--	----------------	--	------------	--

Add the following to the 3^d paragraph

“The tendered rate shall also include full compensation for joint forming, temporary ramping of construction joints between paving operations when new work is opened to traffic (including ramping material), breaking up and disposal of temporary ramps and waste material, weighing the material on the specified weighbridge and cleaning the surface”

SECTION 4400: SINGLE SEALS

B4402 MATERIALS

The nominal rate of application per table 4403/2 is amended to read 1,8L/m²

B44.02 BITUMEN BINDER VARIATIONS

The tenderer shall specify.

SECTION 4800: TREATMENT OF AN EXISTING SURFACE EXHIBITING CERTAIN DEFECTS

B4802 MATERIALS

Add the following paragraphs:

The grade of binder for the slurry seal shall be identified and no tenderer shall deviate from the mix offered. Slurry overlays shall consist of a slurry compound which can be laid as a levelling course and/ or a wearing course on an existing bituminised surface without any tack coat being applied.

SLURRY SEALS (EXCLUDING QUICK SET SLURRY), ITEM 48.03

Slurry seals shall be applied with a spreader box or by hand and can be mixed in a suitable concrete Mixer. The aggregate shall consist of approved crusher stone and shall comply with the following Requirements with regards to grading for a **Fine Coarse grade and Coarse, type 2 Slurry** as per table 4302/11 below.

QUICK- SET SLURRY, ITEM 48.14

Quick- set Slurry shall be applied with a spreader box or by hand and the following will apply:

- Each layer shall be capable of carrying traffic within 2 hours of laying.
- The slurry system shall be a process whereby a rubber modified bitumen emulsion as per table: 4302/5 below with quick set characteristics, is combined with high quality aggregate in a purpose designed machine which applies a continuous cold mix.
- The Rubber Modified Cationic Emulsion Blend shall comply with table 4302/5 below.
- The aggregate shall consist of approved crusher stone and shall comply with the following requirements with regards to grading for a **Fine Slurry, Medium grade** as per table 4302/11 below.

Municipality 1		Municipality 2		Contractor	
----------------	--	----------------	--	------------	--

TABLE B4302/5: CATIONIC MODIFIED BITUMEN EMULSION

Polymer modifier	Required properties					
	Grade of base bitumen	Minimum modified binder content (%)	Minimum viscosity at 50°C Saybolt Furol (seconds)	Maximum residue on sieving (g/100ml)	Particle charge	Sedimentation after 60 rotations
SBR	B8	70	80	0,25	Positive	Nil
	B4	65	70	0,25	Positive	Nil
SBS	B8	70	80	0,25	Positive	Nil
	B4	65	50	0,25	Positive	Nil
Test method		ASTM D244	ASTM D244	SABS 548	SABS 548	SABS 548

TABLE B4302/11: GRADING LIMITS OF AGGREGATES FOR SLURRY SEALS

Sieve size (mm)	Percentage passing sieve, by mass				
	Fine slurry			Coarse slurry	
	Fine grade	Medium grade	Coarse grade	Type 1	Type 2
13,200					100
9,500				100	85-100
6,700		100	100	85-100	70-90
4,750	100	82-100	70-90	70-90	60-80
2,360	90-100	56-95	45-70	45-70	40-60
1,180	65-95	37-75	28-50	25-45	25-45
0,600	42-72	22-50	19-34	15-30	15-30
0,300	23-48	15-37	12-25	10-20	10-20
0,150	10-27	7-20	7-18	6-15	6-15
0,075	4-12	4-12	2-8	4-10	4-10

MIX design

The mix design is to be supplied by the Contractor, Prices tendered are to be based on above proportions with variations as necessary on emulsion and cement.

B4804 MATERIALS

Add the following paragraphs:

Only Bitumen Rubber sealant may be used as specified in the Bill of Quantities

The rubber must meet the requirements as specified in Sabita Manual 4. Bitumen (80/100) must meet the requirements as specified in SABS 307. The bitumen rubber mixture must meet the requirements as specified in Sabita Manual 6 with rubber content 18 to 24%.

B4804 CONSTRUCTION

Add the following paragraphs:

Cracks shall first be blown clean with compressed air (750 kPa) and all foreign and loose matter shall be removed from cracks.

Bitumen rubber at approximately 185 OC must be injected into the cracks by means of hand-operated lance. Immediately after the cracks have been sealed, a scraper is to follow to remove all excess material.

Municipality 1		Municipality 2		Contractor	
----------------	--	----------------	--	------------	--

SECTION 5600: ROAD SIGNS / ROAD FURNITURE

B5600 Scope

The supply and erection of permanent Regulatory, Warning and Hazard Traffic signs as required.

B5602 MATERIALS

Retro – reflective Materials

The materials to be used for signs to be retro-reflective, class II, with a 10 year warranty as per SANS 1519 or similar specification.

Poles

Poles to be painted admiral grey, complying with standard specifications related to traffic signs paint.

Bolts, Nuts and fastenings:

To comply with SANS 135 & SANS 1143 or similar specification. One way nuts to be used on for fastening, where crews are used.

B56.01: MEASUREMENT AND PAYMENT

The unit rates tendered are for each item to be all inclusive for supply, fixing and installation as per Annexure B7 (bolts, nuts, clamps etc. required for fastening) and all other requirements

No additional pay items, other than specified in the Bill of Quantities under Road Signs will be applicable.

B5700 ROAD MARKINGS

B5701 SCOPE / GENERAL REQUIREMENTS

1.1 DELIVERY AND RESOURCE REQUIREMENTS

- The Contractor shall provide a minimum of 1 (one) fully equipped team to complete work orders. Each team shall be capable of applying the equivalent of 1,5 km of 100mm wide lines or 15m² of symbols per day.
- Each team shall be fully equipped with the necessary equipment (mechanical road painting machine and all additional hand operated equipment necessary for completing the work), generator, tools, camera, cellular phone, the South African Road Traffic Signs Manual (SARTSM), and all other incidentals necessary for the completion of the work.
- All records complete with photographs shall be handed in at the MCLM Depot within 1 (one) week after completion.
- All work orders to be completed within the period agreed on reception of the order.

1.2 CONTRACTORS GENERAL RESPONSIBILITIES

- The Contractor shall with due care and diligence execute and complete the works and remedy any defects therein in accordance with the provisions of the Contract.

Municipality 1		Municipality 2		Contractor	
----------------	--	----------------	--	------------	--

- The Contractor shall take all reasonable measures to limit disruption to traffic as far as possible. He shall particularly programme his activities so as to minimise his time of occupation or disruption to traffic.
- Unless otherwise stated, the Contractor shall at his own expense supply and provide all the superintendence, plant (mechanical road painting machine and all additional hand operated equipment necessary), tools, machinery, labour, consumables and facilities required, safety equipment, transport to and from the sites and anything else required for the completion of the works.
- It will be the Contractor's responsibility to liaise with the relevant departments of the MCLM to ascertain the correct positions of stop lines, pedestrian crossings, etc, in order that road markings are applied correctly.
- The Contractor must engage and give preference to local labour in the provision of services and engineering works required for the fulfilment of the Contract.
- The Contractor shall ensure that all his staff maintain cordial approaches, attitude and behaviour to all members of the public.
- Notwithstanding anything previously stated, all works, repairs, connections, etc shall comply with the appropriate Standard Regulations current in the Republic, the local By-Laws at the time of installation and the Traffic Ordinance.

1.3 CONTRACTORS RESPONSIBILITIES RELATED TO COMMUNICATION AND REPORTING PROCEDURES

- The Contractor shall supply the MCLM Project Manager with daily timesheets of work completed. Timesheets will be supplied by the MCLM and an example can be obtained from the MCLM if required by the Bidder.
- The following procedures should take place **before** any project is undertaken by the Contractor:
 - (i) MCLM Project Manager will place an official written order with the Contractor.
 - (ii) The Contractor should identify the appropriate materials and quantities to be supplied and issued by the MCLM and must have it approved by the MCLM Project Manager.
 - (iii) Photographs should be taken of each section of road in at least two directions to confirm the condition of the road prior to commencement of work.
 - (iv) Work order placed with Contractors will be confirmed by the MCLM and scope of work agreed.
 - (v) Contractor and MCLM Project Manager to agree time scales for each project / installation.
 - (vi) Contractor and MCLM Project Manager to agree action-dated deadlines for each project or installation.

After completion of the work the following procedures / inspections should take place:

- (i) Photographs should be taken of the road markings in the same positions as the before photographs. The photograph shall be of a high quality clear with focus showing the road markings along the route and at intersections, in particular. The photograph shall indicate the date of the application by means of an electronic type date imprinted on the photograph.

Municipality 1		Municipality 2		Contractor	
----------------	--	----------------	--	------------	--

- (ii) In the case of new road markings and/or where specified by the MCLM Project Manager, the Contractors shall first apply pre-markings in accordance with the specifications. These premarkings shall be approved by the MCLM Project Manager prior to any painting operations being commenced.
- (iii) The Contractor shall supply the MCLM Project Manager a breakdown of materials used as well as daily timesheets of work completed. All quantities claimed and calculations to be fully computerised for each project.
- (iv) Once the MCLM Quality Assurer is satisfied that the work has been completed in accordance with the MCLM requirements and specifications, the Quality Assurer will issue a final acceptance and approve the hand-over of the installation to the MCLM.
- (v) The MCLM will perform quality control by means of regular on-site spot checks. The MCLM Project Manager will at any time perform random tests of the application rate and quality of the paint being used.
- (vi) The Contractor shall issue an invoice for the project within one week of project sign off.

- Where these communication / reporting procedures are not being adhered to or if the Contractor fails to meet the agreed deadlines on any project, without due notice and reasonable cause for the delay, the MCLM Project Manager may terminate the contract and work will be continued by an alternative contractor or the MCLM and no compensation will be made for work to date on that project.

1.4 CONTRACTORS RESPONSIBILITIES RELATED TO SAFETY

- The Contractor shall at all times observe adequate safety precautions to ensure the safety of the public as well as of his own staff and other persons engaged in or about the Works during the entire period of the Contract. In this respect he shall observe all laws, ordinances and regulations pertaining to his work. The site must be kept in an orderly state appropriated to the avoidance of danger to such persons at all times.
- As the work will be performed mainly in residential areas, the work site must be kept clean and must be cleared on a daily basis.
- The Contractor must at all times bear in mind the requirements of road and pavement users and must cause as little inconvenience and obstruction as possible. Access for the public shall be limited or restricted for as short a period as is reasonably possible.
- When work is carried out within a road reserve, the road surfaces not affected by the work and which remain open to traffic, shall be kept clean and safe at all times.
- The Contractor shall ensure that all relevant duties, obligations and prohibitions imposed in terms of the Occupational Health and Safety Act, 1993 (Act 85 of 1993), and Regulations will be fully complied with at all times. A written agreement in accordance with the Occupational Health and Safety Act must be entered into on award of Bid.
- All reasonable precautions shall be taken to protect workmen against falling material and/or objects and other dangers whilst they are carrying out their duties.
- The Contractor shall provide a properly equipped first-aid box, which shall be accessible at all times.
- The Contractor shall display in a prominent position the telephone numbers of the local police, the ambulance, the fire brigade and the nearest doctor for use in case of an emergency.

Municipality 1		Municipality 2		Contractor	
----------------	--	----------------	--	------------	--

- No worker of the Contractor shall be allowed to do any work in the road reserve without a clean bright orange overall, high visibility pull over, waste coat, jacket or other approved clothing with strips of retro-reflective material and all other safety equipment necessary.
- Where adequate safety precautions are not being observed, the MCLM Project Manager may order the Contractor to comply with minimum safety requirements at the latter's expense. Compliance with such order will not absolve the Contractor from any of his responsibilities and obligations under the Contract. At the discretion of the MCLM Project Manager, he may order the Contractor to move off-site or and work will be continued by another contractor or MCLM and no compensation will be made for work to date on that project.

1.5 CLIENTS RESPONSIBILITIES

- Furnish the contractor with written instructions, drawings, documentation etc indicating the project site and the nature and extent of work to be performed as required. Where a Consultant has been appointed this will form part of their responsibility.
- Specify the locations and details of the road markings to be applied by the Contractor.

B5702 MATERIALS

1.1 Introduction

Road markings will be applied using hot-applied thermoplastic, cold plastic paint, standard road-marking paint and/or any approved alternative materials or products offered by the Bidder.

Thermoplastic material is applied hot with an appropriate hand or mechanical applicator. It sets on laying and forms a cohesive film by cooling. The MCLM will require the use of thermo-plastic material because of its good durability. On motorways and other high order roads, mechanical application will be required as it can be laid in long runs using motorised equipment with minimum disruption to traffic.

Cold plastic paint is a marking material supplied in single or multi-component forms. Depending on the type of system the components are mixed together in various ratios and applied with an appropriate applicator. It forms a cohesive film only by a chemical process.

Other materials that Bidders may offer could include preformed thermo or cold plastic material which is applied to the road surface using an adhesive. Preformed tape is produced in sheet or roll form and is either bonded to the road surface or inlaid. The advantage of preformed markings is that they have good durability, are of uniform thickness and do not spread in hot weather or under the weight of heavy traffic.

Preformed thermoplastic road markings are applied by heating the material until it bonds to the road surface by melting or fusion. They provide a simple way to apply arrows, lettering etc. and to reinstate short lengths of line without the need for substantial application and support equipment.

1.2 Standard road-marking paint

Standard road-marking paint complying with SANS 731 shall be provided by the contractor. **The paint may not be thinned down by the Contractor.**

1.3 Retro-reflective road-marking paint

Retro-reflective road-marking paint complying with CKS 192 and SANS 731 shall be supplied by the Contractor. **The paint may not be thinned down by the Contractor.** The Contractor shall return the empty containers at the end of the each workday for quantity control and payment.

Municipality 1		Municipality 2		Contractor	
----------------	--	----------------	--	------------	--

1.4 Colour

The colours to be used shall be bright white, or red. The colour of the and red road marking materials shall be as specified in SANS 731-1.

1.5 Retro-reflectivity

Retro-reflectivity is the ability of a white line to reflect light from a vehicle's headlights back to the driving position of a vehicle. The materials offered shall have at least 100 millicandelas per lux per square metre(mcd/lux/m²),, but preferably 250 mcd/lux/m², at 7 days, and 200 mcd/lux/m² after 6 months.

The MCLM Quality Assurer may from time to time perform spot checks to ensure compliance with retro-reflectivity

B5703 WEATHER LIMITATIONS

Road marking paint shall not be applied to a damp surface or at temperatures lower than 10°C, or when, in the opinion of the MCLM Quality Assurer, the wind strength is such that it may adversely affect the painting operations.

B5704 MECHANICAL EQUIPMENT FOR PAINTING

The equipment shall consist of an apparatus for cleaning the surfaces, a mechanical road marking machine and all additional hand-operated equipment necessary for completing the work.

The machine shall be so designed that it will be capable of painting the road markings everywhere to uniform width with sides within the tolerances specified, without the paint running or splashing.

The machine shall further be capable of painting lines of different widths by adjusting the spray jets on the means or by means of additional equipment attached to the machine.

The machine shall be equipped with a device that will enable the driver to follow a target on the roadway or to follow previously placed lines. The machine shall be capable of adjusting the spacing of dotted lines in such a way that existing road markings can be reinstated.

The machine shall be capable of spraying at a speed of not less than 5,0 km/h and shall be provided with clearly visible warning flashing lights which shall always be in operation when the machine is on the road.

The mechanical road marking machine shall be capable of applying two types of retro-reflective beads as the MCLM will supply Contractors with wet and dry beads.

B5705 SURFACE PREPARATION

Before any paint is applied, the road surface shall be clean and dry and completely free from any soil, grease, oil, acid or any other material which will be detrimental to the bond between the paint and the road surface. The surface where the road-marking materials is to be applied shall be properly cleaned by means of watering, brooming or compressed air if required.

Traffic markings shall be applied to new bituminous surfaces only after sufficient time has elapsed to ensure damage will not be caused to the painted surface by volatiles evaporating from the road surface.

Where road markings are to be applied to a concrete pavement, an armour coat based primer or similar approved by the MCLM shall be applied before any road markings are applied. The primer shall be provided by the Contractor and the rates provided in the Schedule of rates shall make allowance for this. Particular care shall be taken to ensure the surface shall be clean.

Thermoplastic road marking material must be applied to a dry road surface, with no surface dampness, dew or subsurface wetness to ensure good adhesion. The ambient temperature shall be above 10°C or the temperature recommended by the Manufacturer.

Municipality 1		Municipality 2		Contractor	
----------------	--	----------------	--	------------	--

B5706 SETTING OUT THE ROAD MARKINGS

The dimensions and positions of road markings required by the MCLM shall be shown on the drawings provided by the MCLM and shall be in accordance with SARTSM.

In the case of new road markings, the lines, symbols, figures or marks shall be premarked by means of paint spots of the same colour as that of final lines and marks. These points shall be at such intervals as will ensure that the traffic markings can be applied, and in no case shall they be more than 1,5 m apart. Normally spots of approximately 10mm in diameter should be sufficient.

After premarking the positions of the proposed road markings such as broken lines and the starting and finishing points of barrier lines shall be indicated on the road. These premarkings shall be approved by the MCLM Project Manager prior to any painting operations being commenced.

The positions and outlines of special markings shall be produced on the road surface in chalk and shall be approved by the MCLM Project Manager before they are fixed in position.

B5707 APPLYING THE PAINT

The figures, letters, signs, symbols, broken or unbroken lines or other markings shall be painted in accordance with the instructions of the MCLM Project Manager and SARTSM.

Where the paint is applied by machine, it shall be applied in one layer. The Contractor shall ensure the satisfactory operation of the road-marking machine before the machine is used on the actual road surface. It shall be tested on a suitable site which is not part of the roadway. Adjustments to the machine shall be followed by further testing. Only when the machine has been correctly adjusted and its use has been approved by the MCLM Quality Assurer may the machine be used on the permanent work. The operator shall be experienced in the use of the machine.

After the machine has been satisfactorily adjusted the rate of application shall be checked and adjusted if necessary before application on a large scale is commenced.

The paint shall be stirred before application in accordance with the manufacturer's instruction. Paint shall be applied without the addition of thinners.

Standard road-marking paint shall be applied at a nominal rate of 1,0 ℓ/m² or as directed by the MCLM Project Manager and proprietary brands shall be applied at the rates specified by the Manufacturer.

B5708 APPLYING THE RETRO-REFLECTIVE BEADS

The beads shall be dropped or sprayed onto the paint layer, the beads can be pre-mixed in paint or other material before application or a proportion of the beads can be dropped on pre-mixed materials.

The preferred method is that of spraying (under pressure) or dropping (under gravity) beads onto the wet road-marking material basically simultaneously with the paint application.

The mechanical road marking machine shall be capable of applying two types of retro-reflective beads as the MCLM will supply Contractors with wet and dry beads.

Where retro-reflective paint is required the retro-reflective beads shall be applied by means of a suitable machine in one continuous operation, immediately after the paint has been applied. The rate of application of the beads shall be 0,6 to 0,8 kg/ℓ of paint or such other rate as may be directed by the MCLM Project Manager.

B5712 FAULTY WORKMANSHIP OR MATERIALS

Municipality 1		Municipality 2		Contractor	
----------------	--	----------------	--	------------	--

If any material which does not comply with the requirements or if the MCLM Quality Assurer find that any road marking material has been thinned down, or if any work of an unacceptable quality is carried out such material or work shall be removed, replaced or repaired as required by the MCLM Quality Assurer at the Contractor's own cost.

- Rejected traffic markings and paint which has been splashed or dripped onto the pavement, kerbs, structures or other such surfaces, shall be removed by the contractor at his own cost in an approved manner so that the markings or spilt paint will not show up at all.
- The MCLM Project Manager / Quality Assurer shall have authority to randomly inspect or test the application rate of the road marking materials.
- The MCLM Project Manager / Quality Assurer shall have authority to randomly inspect or test any material that is being used on site to ensure that the quality is in accordance with the specifications or that road marking materials free-issued by the MCLM has not been thinned down or modified in any way.
- If found that the Contractor has modified the material in anyway, the MCLM Project Manager may terminate the contract and work will be continued by another contractor or MCLM and no compensation will be made for work to date on that project.
- Should any of the work carried out by the Contractor, become defective within a period of twelve (12) months as a result of poor workmanship or negligence on the side of the Contractor, the Contractor will be ordered to re-execute the work at no cost to the MCLM. Should the Contractor fail to comply with this order, the MCLM Project Manager shall have the right to remove and have the work reinstated by another contractor or the MCLM and the cost will be recovered from the Contractor.

QUALITY AND GUARANTEE

- If at any time after delivery the MCLM Project Manager shall be dissatisfied with the workmanship, the contractor shall immediately remedy the said defect to the specification provided by the Engineer.
- Should the Contractor delay remedial work in excess of the time stipulated by the MCLM's representative, the MCLM Project Manager may have such remedial work executed at the contractor's expense.
- The guarantee period against faulty and poor workmanship or negligence on the side of the Contractor shall be twelve (12) months after the issuing of the final acceptance of the installation.
- The Hot-Applied Thermo Plastic Paint, cold applied plastics and/or and alternative products offered shall clearly state the details of the guarantee for approval by the MCLM.

B5713 PROTECTION

After the paint has been applied, the traffic markings shall be protected against damage by traffic or other causes. The Contractor shall be responsible for erecting, placing and removing warning boards, flags, cones, barricades, and other protective measures which may be necessary in terms of any statutory provision and/or as may be recommend SARTSM.

B5714 MEASUREMENT AND PAYMENT

57.02 Applying retro-reflective road marking paint

- The unit of measurement for painting the lines shall be a kilometre of each specifof line and the quantity paid for shall be actual length of line painted in accordance with the instructions of the MCLM Project Manager and SARTSM, excluding the gaps in broken lines.

Municipality 1		Municipality 2		Contractor	
----------------	--	----------------	--	------------	--

- The unit of measurement for painting the lettering, symbols or traffic island markings shall be a square meter and the quantity to be paid for shall be the actual surface area of lettering, symbols or traffic island markings complete. Distinction shall be made between the different types of lines, islands and colour of the markings.
- The Bid rate per kilometre or per square metre as the case may be for painting the traffic markings shall include full compensation for materials and providing the necessary labour and equipment, and for painting and protecting as specified, including the setting out of lettering, symbols and traffic island markings, but excluding setting out and premarking the lines.

57.06 Setting out and pre-marking the lines

- The unit of measurement for setting out lines (excluding traffic-island markings, lettering and symbols) shall be the kilometre of lines set out and marked. Where two or three lines are to be painted next to each other, the setting-out of lines shall be measured only once.
- The Bid rate shall include full compensation for setting out and premarking the lines as specified, including all materials. Paint for premarking will not be free-issued by the MCLM.

57.08 Removal of existing, temporary or permanent road markings

- The unit of measurement shall be the square metre of existing road markings removed by means of sand blasting, water jetting / hydro blasting on the instruction of the MCLM Project Manager. Over-painting markings with black paint or bituminous solutions is not allowed.
- The tendered rates shall include full compensation for sand, all plant, labour, consumables, water, cleaning of the road surface and all other costs involved.
- Separate payment will be made for establishment on site. Contractors will be paid for one site establishment for all orders placed at the same time within a 5km radius.

SECTION 8100: TESTING MATERIALS AND WORKMANSHIP

81.01 Scope

- Include the following: During the process of the work test shall be conducted on materials and workmanship to ensure compliance with the requirements and specifications **“or as directed by the Engineer”**

81.02 Testing Methods

All tests shall be conducted in accordance with the standard methods as specified and in the order of preference as per Section 8102.

81.03 The Costs of Testing

The tendered rates for various items of works to make provision for testing as per clause 1205, 8103 (a) for the purpose of process control.

Should further testing, be required by the Engineer, these costs will form part of Contingencies.

Municipality 1		Municipality 2		Contractor	
----------------	--	----------------	--	------------	--

81.17 Measurement and Payment

The following will apply:

- Tendered rates to include all standard testing required for process control purposes, as per clause 1205.
- Where it is required or instructed by the Engineer that further testing be performed, this will be covered under Contingencies, provided in the Bill of Quantities.

8200: QUALITY CONTROL

During the process of the work the contractor shall conduct required tests on materials and workmanship as required to ensure compliance with the requirements and specifications in terms of his obligations under clause 1205.

No other Quality Control Scheme is required.

82. 17 Measurement and Payment

Where additional testing / material designs etc. are required as directed by the Engineer, this to be paid under Contingencies with the Contractor to obtain quotations, inclusive of a mark up for handling fees, not exceeding 10%.

A PC sum has been provided in the Bill of Quantities, with tests to be claimed under Contingencies

GENERIC SPECIFICATION

C3.7 GENERIC SPECIFICATIONS

The specifications in Part 3 is Generic (In-house) Specifications prepared by the employer applicable to this contract.

**ANNEXURE A
 NOTIFICATION OF CONSTRUCTION WORK
 Regulation 3 of the construction Regulations, 2003**

1. (a) Name and postal address of principal Contractor:

.....

(b) Name and telephone number of principal Contractor’s contact person:

.....

2. Principal Contractor’s compensation registration number:

.....

Municipality 1		Municipality 2		Contractor	
----------------	--	----------------	--	------------	--

3. (a) Name and postal address of Client:

.....

(b) Name and telephone number of Client's contact person or agent:

.....

4. (a) Name and postal address of designer(s) for the project:

.....

(b) Name and telephone number of designer's contact person:

.....

5. Name and telephone number of principal Contractor's construction supervisor on site appointed in terms of regulations 6 (1):

.....

6. Name/s of principal Contractor's sub-ordinate supervisors on site appointed in terms of regulation 6 (2):

.....

7. Exact physical address of the construction site or site office:

.....

8. Nature of the construction work:

.....

.....

.....

9. Expected commencement date:

.....

10. Expected completion date:

.....

11. Estimated maximum number of persons on the construction site:

.....

12. Planned number of Contractors on the construction site accountable to principal Contractor:

.....

13. Name(s) of Contractors already chosen:

.....

.....

.....

Municipality 1		Municipality 2		Contractor	
----------------	--	----------------	--	------------	--

MOGALE CITY LOCAL MUNICIPALITY
TENDER NO: PWRT (R&T) xx/2021: **REHABILITATION AND RESURFACING OF ROADS AS PER THE ANNUAL ROADS
PROJECT PLANS OVER A PERIOD OF 36 MONTHS**

.....
Principal Contractor

.....
Date

.....
Client

.....
Date

- THIS DOCUMENT IS TO BE FORWARDED TO THE OFFICE OF THE DEPARTMENT OF LABOUR **PRIOR TO COMMENCEMENT** OF WORK ON SITE.
- **ALL PRINCIPAL CONTRACTORS** THAT QUALIFY TO NOTIFY MUST DO SO EVEN IF ANOTHER PRINCIPAL CONTRACTOR ON THE SAME SITE HAD DONE SO PRIOR TO THE COMMENCEMENT OF WORK.

Municipality 1		Municipality 2		Contractor	
----------------	--	----------------	--	------------	--

ANNEXURE B

**OCCUPATIONAL HEALTH AND SAFETY
AUDIT SYSTEM**

ADMINISTRATIVE & LEGAL REQUIREMENTS

Subject	Requirements	Yes/No
Notice of carrying out Construction work	Department of Labour notified Copy of Notice available on Site.	
Copy of OH&S Act (Act 85 of 1993)	Updated copy of Act & Regulations on site Readily available for perusal by employees.	
Registration with Compens. Insurer	Written proof of registration / Letter of good standing available on Site.	
OH&S Specification & Plan	OH&S Specification received from Client OH&S plan developed Updated regularly.	
Hazard Identification & Risk Assessment	Hazard Identification carried out/recorded Risk Assessment and Plan drawn up/updated Risk Assessment Plan available on Site Employees/Subcontractors informed/trained.	
Assigned duties (Managers)	Responsibility of complying with the OH&S Act assigned to other person/s by CEO.	
Designation of Person Responsible on Site	Competent person appointed in writing as Construction Supervisor.	
Designation of Subordinate Person	Competent person appointed in writing as Sub-ordinate Construction Supervisor.	
Designation of Occupational Health & Safety Representatives	More than 20 employees – one OH&S Representative, one additional OH&S Rep. For each 50 employees or part thereof. Designation in writing, period and area of responsibility specified. Meaningful OH&S Rep. Reports. Reports auctioned by Management.	
Occupational Health & Safety Committee/s	OH&S Committee/s established. Members appointed in writing. Meetings held monthly. Minutes kept. Actioned by Management.	
Agreement with Mandatories (Subcontractors)	Written agreement with Subcontractors. List of Subcontractors displayed. Proof of Registration with Compensation Insurer/Letter of Good Standing Construction Work Supervisor designated Written arrangements concerning OH&S Reps & OH&S Committee Written arrangements regarding First Aid.	

Municipality 1		Municipality 2		Contractor	
----------------	--	----------------	--	------------	--

Subject	Requirements	Yes/No
Fall Prevention & Protection	Competent person appointed to draw up and supervise the Fall Protection Plan Proof of appointees competence available on Site Risk Assessment carried out for work at heights Fall Protection Plan drawn up/updated Available on Site.	
Roofwork	Competent person appointed to plan & supervise Roofwork. Proof of appointees competence available on Site Risk Assessment carried out. Roofwork Plan drawn up/updated. Roofwork inspect before each shift. Inspection register kept Employees medically examined for physical & psychological fitness. Written proof available.	
Structures	Information re. The structure being erected received from the Designer including: <ul style="list-style-type: none"> - Geo-science technical report where relevant. - The design loading of the structure. - The methods & sequence of construction. - Anticipated dangers / hazards / special measures to construct safely. Risk Assessment carried out Method statement drawn up All above available on Site Structures inspected before each shift. Inspections register kept.	
Formwork & Support work	Competent person appointed in writing to supervise erection, maintenance, use and dismantling of Support & Formwork Design drawings available on site Risk Assessment carried out Support & Formwork inspected: <ul style="list-style-type: none"> - Before use/inspection. - Before pouring of concrete. - Weekly whilst in place. - Before stripping/dismantling. Inspection register kept. 	
Scaffolding	Competent persons appointed in writing to: <ul style="list-style-type: none"> - Erect scaffolding (Scaffold Erector/s). - Act as Scaffold Team Leaders. - Inspect Scaffolding weekly and after inclement weather (Scaffold Inspector/s). - Written Proof of Competence of above appointees available on Site. - Copy of SABS 085 available on Site. - Risk Assessment carried out. - Inspected weekly/after bad weather. Inspection register/s kept. 	

Municipality 1		Municipality 2		Contractor	
----------------	--	----------------	--	------------	--

Subject	Requirements	Yes/No
Suspended Scaffolding	<p>Competent persons appointed in writing to:</p> <ul style="list-style-type: none"> - Erect scaffolding (Scaffold Erector/s). - Act as Scaffold Team Leaders - Inspect Scaffolding weekly and after inclement weather (Scaffold Inspector/s) Risk Assessment conducted. <p>Certificate of Authorization issued by a registered professional Engineer available on Site/copy forwarded to the Department of Labour.</p> <p>The following inspections of the whole installation carried out by a competent person</p> <ul style="list-style-type: none"> - After erection and before use. - Daily prior to use. Inspection register kept. <p>The following tests to be conducted by a competent person:</p> <ul style="list-style-type: none"> - Load test of whole installation and working parts every 12 months. - Hoisting ropes/hooks/load attaching devices quarterly. Tests log book kept - Employees working on Suspended scaffold medically examined for physical & psychological fitness. Written proof available. 	
Excavations	<p>Competent person/s appointed in writing to supervise and inspect excavation work</p> <p>Written Proof of Competence of above appointee/s available on Site</p> <p>Risk Assessment carried out</p> <p>Inspected:</p> <ul style="list-style-type: none"> - Before every shift. - After any blasting. - After an unexpected fall of ground. - After any substantial damage to the shoring. - After rain. Inspections register kept. - Method statement developed where explosives will be/are used. 	
Demolition Work	<p>Competent person/s appointed in writing to supervise and control Demolition work.</p> <p>Written Proof of Competence of above appointee/s available on Site</p> <p>Risk Assessment carried out.</p> <p>Engineering survey and Method Statement available on Site.</p> <p>Inspections to prevent premature collapse carried out by competent person before each shift. Inspection register kept.</p>	
Materials Hoist	<p>Competent person appointed in writing to inspect the Material Hoist.</p> <p>Written Proof of Competence of above appointee available on Site.</p> <p>Materials Hoist to be inspected weekly by a competent person.</p> <p>Inspections register kept.</p>	
Caissons & Cofferdams	<p>Competent person appointed in writing to supervise, control & inspect the construction, installation/dismantling of caissons/coffer dams.</p> <p>Written Proof of Competence of above appointee available on Site</p> <p>Risk Assessment carried out to be inspected daily by a competent person.</p> <p>Inspections register kept.</p>	

Municipality 1		Municipality 2		Contractor	
----------------	--	----------------	--	------------	--

Explosive Powered Tools	Competent person appointed to control the operation of the Batch Plant and the service, maintenance and cleaning. Register kept of above Risk Assessment carried out. Batch Plant to be inspected weekly by a competent person. Inspections register kept.	
Batch Plants	Competent person appointed to control the operation of the Batch Plant and the service, maintenance and cleaning. Register kept of above. Risk Assessment carried out. Batch Plant to be inspected weekly by a competent person. Inspection register kept	
Tunnelling	Complying with Mines Health & Safety Act (29 of 1996). Risk Assessment carried out	
Cranes & Lifting Machines Equipment	Competent person appointed in writing to inspect Cranes, Lifting Machines & Equipment Written Proof of Competence of above appointee available on Site. Cranes & Lifting tackle identified/numbered. Register kept for Lifting Tackle. Log Book kept for each individual Crane. Inspection: <ul style="list-style-type: none"> - All cranes – daily by operator. - Tower Crane/s – after erection/6 monthly. - Other cranes – annually by comp. person. - Lifting tackle (slings/ropes/chain slings etc.) – 3 monthly. - Risk Assessment carried out. 	
Inspection & Maintenance of Electrical Installation & Equipment (including portable electrical tools)	Competent person appointed in writing to inspect/test the installation and equipment. Written Proof of Competence of above appointee available on Site. Inspections: <ul style="list-style-type: none"> - Electrical Installation & equipment inspected after installation, after alterations and quarterly. Inspection Registers kept. - Portable electric tools and – lights and extension leads identified/numbered. - Monthly visual inspection by User/Issuer/Storeman. Register kept. 	
Water Environments	Competent person appointed in writing to supervise diving operations and ensure maintenance, statutory inspection and testing by an Approved Inspection Authority of equipment used. Written Proof of Competence of above appointee available on Site. Proof of registration of all divers present on site available. Risk Assessment carried out. Diving Manual produced. Available on Site Record of Voice Communications kept. Diving Operations record kept. Each Diver keeps a personal logbook. Entries countersigned by the diving Supervisor.	

Municipality 1		Municipality 2		Contractor	
----------------	--	----------------	--	------------	--

Subject	Requirements	Yes/No
	Decompression tables available on Site. Records of any Decompression illness kept. Certificate of Manufacture of any Compression Chamber or Diving Bell in use available on Site.	
Designation of Stacking & Storage Supervisor	Competent Person/s with specific knowledge and experience designated to supervise all Stacking & Storage. Written Proof of Competence of above appointee available on Site.	
Designation of a Person to Co-ordinate Emergency Planning And Fire Protection	Person/s with specific knowledge and experience designated to co-ordinate emergency contingency planning and execution and fire prevention measures. Emergency Evacuation Plan developed: Drilled/Practiced. Plan & Records of Drills/Practices available on Site. Fire Risk Assessment carried out. All Fire Extinguishing Equipment identified and on register. Inspected weekly. Inspection Register kept. Serviced annually.	
First Aid	Every workplace provided with sufficient number of First Aid boxes. (Required where 5 persons or more are employed). First Aid freely available. Equipment as per the list in the OH&S Act. One qualified First Aider appointed for every 50 employees. (Required where more than 10 persons are employed). List of First Aiders and Certificates. Name of person/s in charge of First Aid box/es displayed. Location of First Aid Box/es clearly indicated. Signs instructing employees to report all injuries/illness including first aid injuries.	
Personal Safety Equipment (PSE)	PSE Risk Assessment carried out. Items of PSE prescribed/use enforced. Records of Issue kept. Undertaking by Employee to use/wear PSE.	
*Inspection & Use of Welding/Flame Cutting Equipment	Competent Person/s with specific knowledge and experience designated to Inspect Electric Arc, Gas Welding and Flame Cutting Equipment. Written Proof of Competence of above appointee available on Site. Equipment identified/numbered and entered into a register. Equipment inspected monthly. Inspection Register kept.	
*Control of Storage & Usage of HCS	Competent Person/s with specific knowledge and experience designated to Control the Storage & Usage of HCS. Written Proof of Competence of above appointee available on Site. Risk Assessment carried out. Register of HCS kept/used on Site.	

Municipality 1		Municipality 2		Contractor	
----------------	--	----------------	--	------------	--

Subject	Requirements	Yes/No
Vessels under Pressure (VUP)	Competent Person/s with specific knowledge and experience designated to supervise the use, storage, maintenance, statutory inspections & testing of VUP's. Written Proof of Competence of above appointee available on Site Risk Assessment Carried out. Certificates of Manufacture available on Site. Register of VUP's on Site. Inspections & Testing by Approved Inspection Authority (AIA): After installation/re-erection or repairs every 36 months. Register/Log kept of inspections, tests. Modifications & repair.	
Construction Vehicles & Earth Moving Equipment	Operators/Drivers appointed to: Carry out a daily inspection prior to use. Drive the vehicle/plant that he/she is competent to operate/drive. Written Proof of Competence of above appointee available on Site. Record of Daily inspections kept.	
Inspection of Ladders	Competent person appointed in writing to inspect Ladders. Ladders inspected at arrival on site and monthly there after. Inspections register kept.	
Ramps	Competent person appointed in writing to Supervise the erection & inspection of Ramps. Inspection register kept.	

Municipality 1		Municipality 2		Contractor	
----------------	--	----------------	--	------------	--

Safety and Fire Rules

SAFETY AND FIRE RULES FOR CONTRACTORS ON THE PREMISES

- i. All persons on company premises shall obey all health and safety rules, procedures and practices. In particular, NO SMOKING signs and the prohibition of the carrying of smoking materials in designated areas shall always be obeyed.
- ii. All the applicable requirements of the Occupational Health and Safety Act (1993) and Regulations and any amendments thereto, shall be met.
- iii. Where the OHS Act prescribes certification of competency of persons performing certain tasks, proof of such certification shall be provided prior to signing of the contract or commencement of work.
- iv. The Contractor’s Workmen’s Compensation fees must be up to date. A copy of Contractor’s WCA registration shall be produced on request. WCA Registration No. of the Contractor company.....

Any process involving open flames, sparks or heat shall be authorized by the issue of a permit to work, obtained from the officials designated as permit issuer. Any work done under the protection of a permit to work shall be in strict compliance with every prescription on the permit.

- v. Safety equipment shall be used where applicable, (e.g. safety goggles, boots, harness, etc.). The Contractor shall provide this at his own expense. The Contractor shall apply the necessary discipline and control to ensure compliance by his workers.
- vi. All work shall be done during normal working hours, unless otherwise instructed or agreed in writing.
- vii. The contractor shall maintain good housekeeping mandates in the area where he is working for the duration of the contract.

Signed _____

Date

Name _____

Position

Tenderer _____

Municipality 1		Municipality 2		Contractor	
----------------	--	----------------	--	------------	--

PART C4 : SITE INFORMATION

Municipality 1		Municipality 2		Contractor	
----------------	--	----------------	--	------------	--

C4 SITE INFORMATION

C4.1. Site of Works

The site of works are situated throughout Mogale City.

C4.2. Nature of Ground and Subsoil Details

The insitu material of the existing gravel roads are of a good quality for road construction. The material is classified as intermediate for excavation purposes.

C4.3 Environmental Compliance

The Environmental Consultants – Newtown Landscape Architects confirmed that the proposed construction activity does not trigger any environmental compliance issues and that construction can proceed without a RoD.

C4.4 Landownership

The land forms part of a Municipal township.

Municipality 1		Municipality 2		Contractor	
----------------	--	----------------	--	------------	--

ANNEXURE A

OCCUPATIONAL HEALTH AND SAFETY ACT (ACT NO. 85, 1993)

Contractor to obtain his own copy of the Act for reference purposes.

Municipality 1		Municipality 2		Contractor	
----------------	--	----------------	--	------------	--

ANNEXURE B

REDUCED DRAWINGS FOR TENDER PURPOSES ONLY

(WILL BE PROVIDED ON REQUEST AS REQUIRED)

Municipality 1		Municipality 2		Contractor	
----------------	--	----------------	--	------------	--

ANNEXURE B1

TYPICAL PIPE BEDDING DETAILS

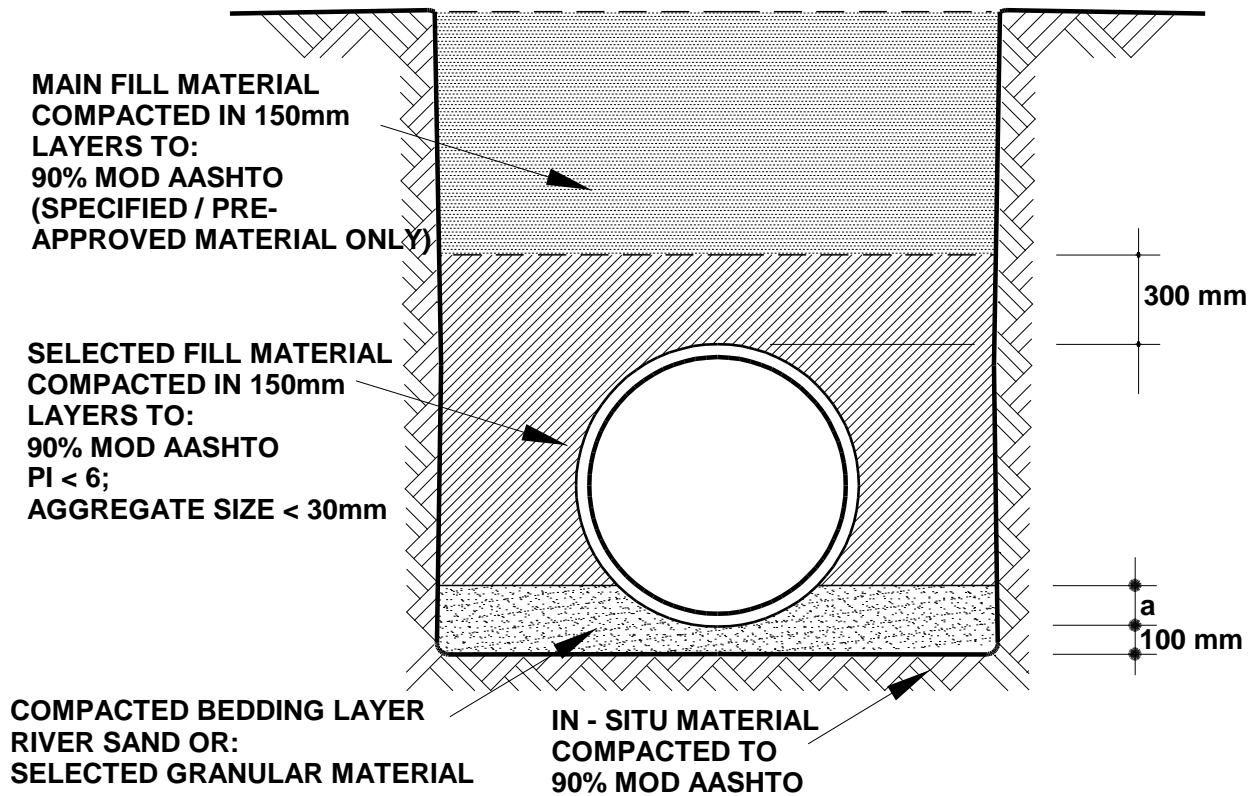

NOTES:

FILL MATERIAL TO BE PRE- APPROVED BY THE ENGINEER

Pipe dia.	Dimension (a)
450 mm	75 mm
600 mm	100 mm
750 mm	125 mm
900 mm	150 mm

- ❖ Setting out and level indicators to be done by employer's representative/surveyor.
- ❖ Pipes to be 100d, Ogee joints, interlocking.
- ❖ Joints to be sealed with sand cement mix 3:1;
- ❖ Class B bedding is applicable.
- ❖ Backfilling to be done in accordance to Class B bedding and be equal to the excavated layerworks.
- ❖ Compact base and sub-base material layers to 93% MOD AASHTO.

Rate is inclusive of all plant requirements, supply and install and the removing and disposing of excavated material

Municipality 1		Municipality 2		Contractor	
----------------	--	----------------	--	------------	--

ANNEXURE B2

Specifications for reinstatement of Storm water catch pits (Kerb-master Type or similar type)

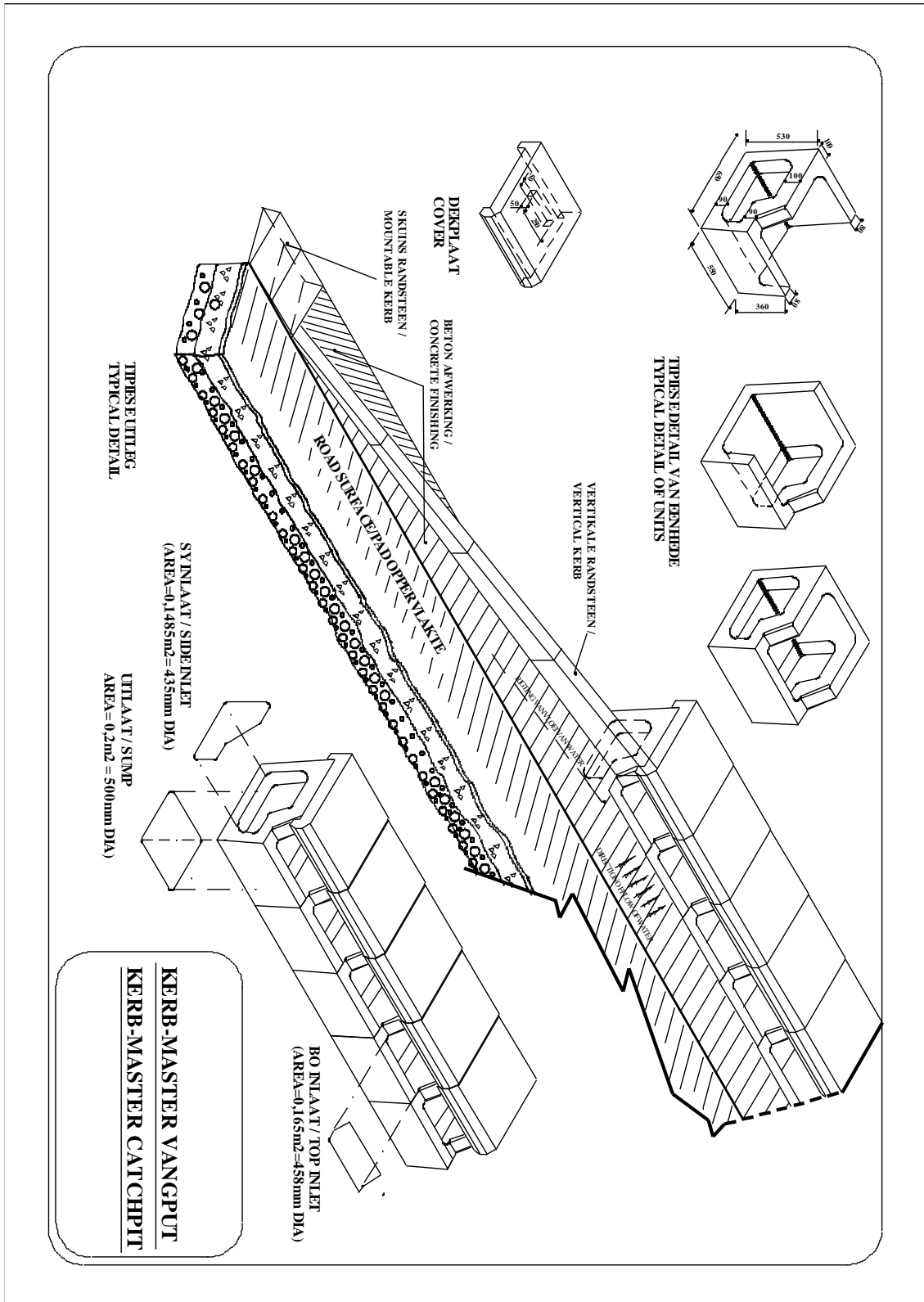

Municipality 1	Municipality 2	Contractor	
----------------	----------------	------------	--

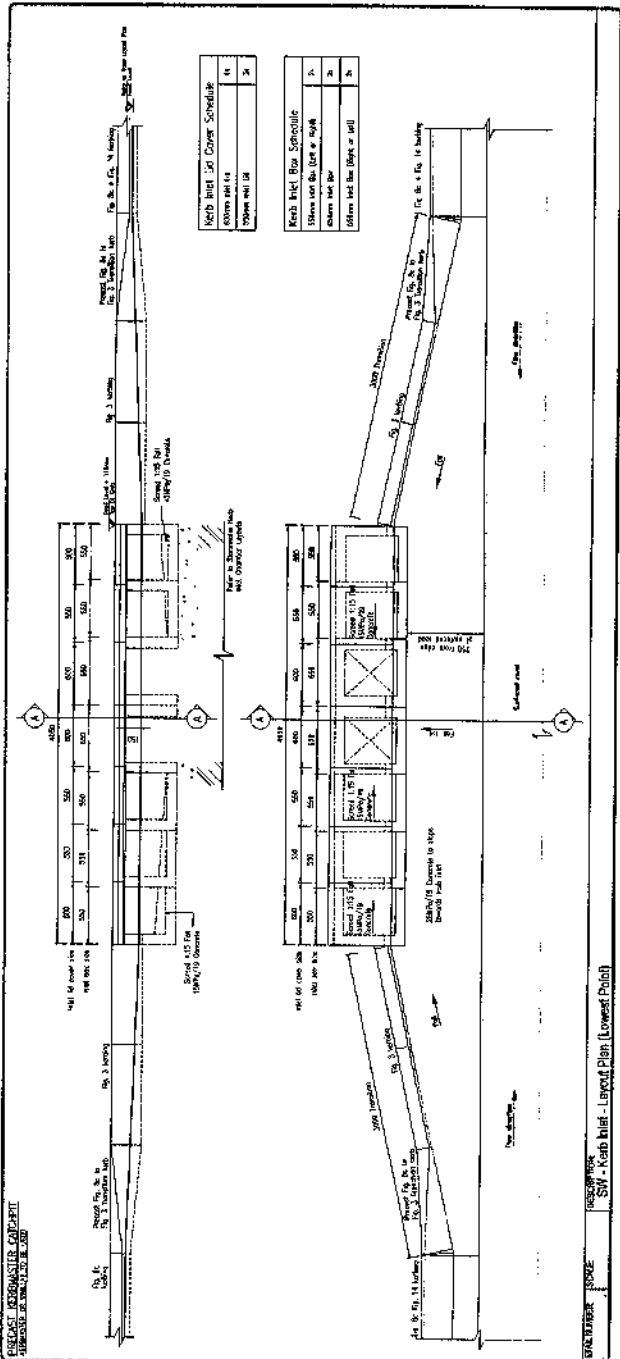
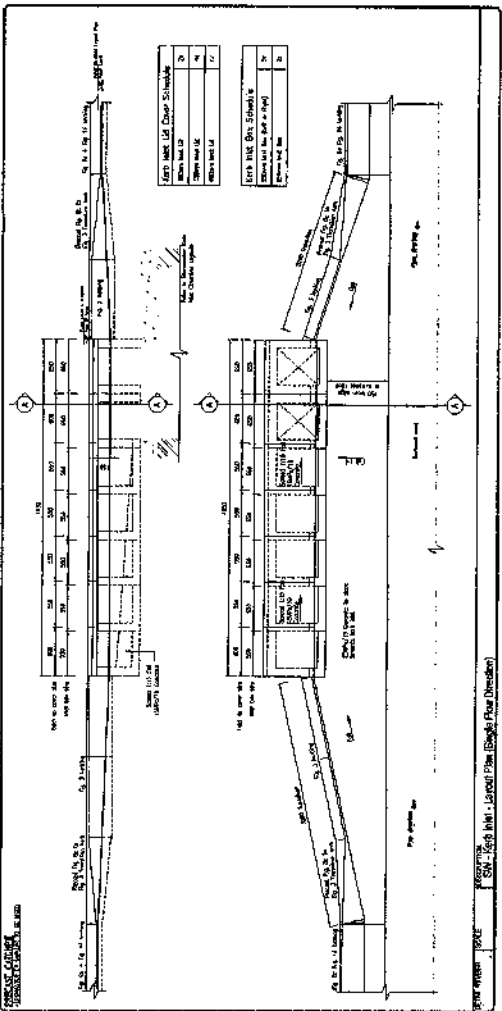
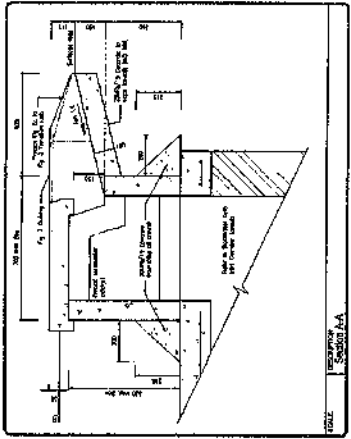

ANNEXURE "E1"

Municipality 1		Municipality 2		Contractor	
----------------	--	----------------	--	------------	--

ANNEXURE B3

Specifications for reinstatement of Storm water catch pits: Various Types

The work to be done includes the following:

1. Barricade work area during construction work.
2. Build double course brick work pillars to support lintols.
3. Pillars to be plastered.
4. Replace stole/ vandalized frames with lintols to support concrete slabs.
5. Fit new 900x900x75mm cover slabs as below.
6. Remove old cover slabs and deliver to Chamdor Municipal yard.
7. Should it be required that existing kerbs need to be replaced, thjis will be paid separately under the item provided for kerbs.



75mmx 75mm x 900mm cover slabs,

2 x 75mmx 110mm



PLAN

220 x 220 brickwork, plastered,
2-3 courses @ 1.5m-1.8m spacing

75mmx 75mm x
900mm cover slabs.

Municipality 1		Municipality 2		Contractor	
----------------	--	----------------	--	------------	--

ANNEXURE B4

Specifications for Supply and fitting of Cast Storm water catch pit cover slabs, complete with footing

Replacement Sizes and specifications

Concrete strength: 25 Mpa , reinforcing ; Y10's @ 75mm crs

Dimensions:

- 600mm/ 900mm/1200mm/1500mm/1800mm/3000mm (L) x 600mm (W) x 75mm thickness

The work to be done includes the following:

1. Barricade work area during construction work.
2. Remove old cover slabs and clean the inside of drain.
Re-usable slabs to be delivered to Chamdor Municipal yard.
3. Fit new purpose made cover slabs as detailed below. Where it is impractical to manufacture the cover slabs off – site, due to the size it may be cast in-situ.
4. Should it be required that existing kerbs need to be replaced, this will be paid separately under the item provided for kerbs.

Typical detail

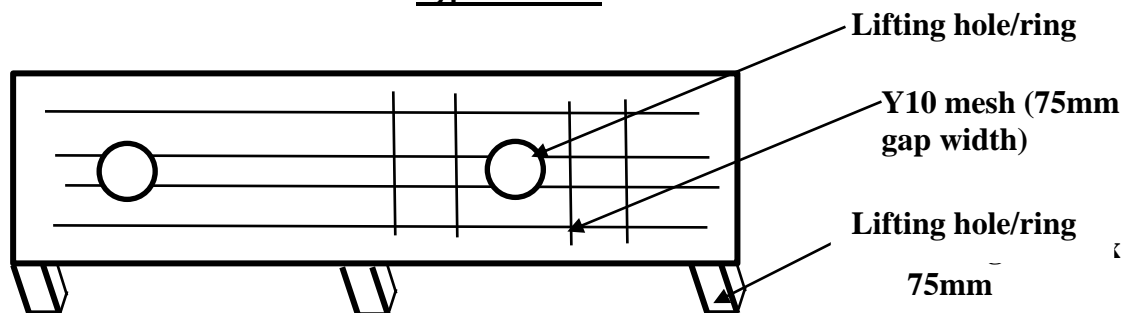

Concrete footing required every 600mm

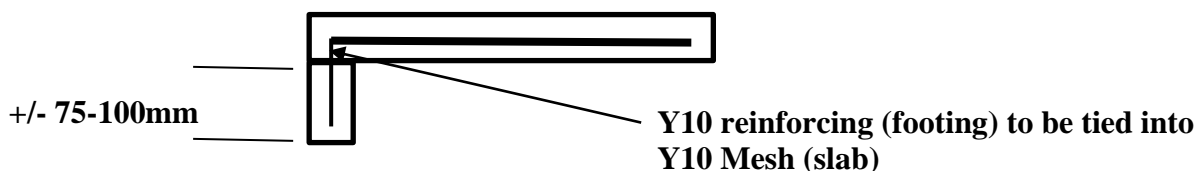

Municipality 1		Municipality 2		Contractor	
----------------	--	----------------	--	------------	--

ANNEXURE B5

Specifications for Concrete manholes

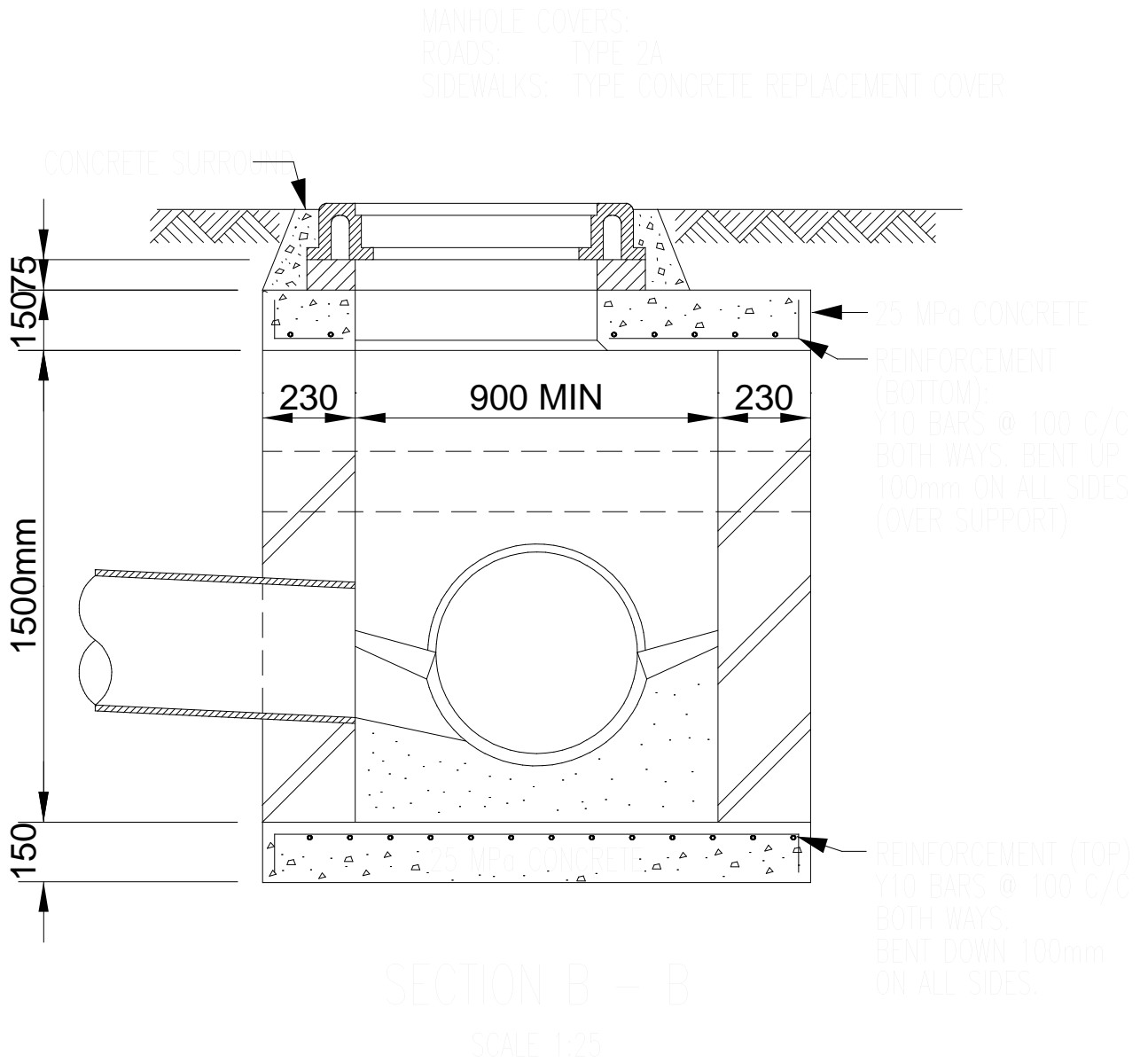

Municipality 1		Municipality 2		Contractor	
----------------	--	----------------	--	------------	--

ANNEXURE B6

Specifications for Laying of Kerbs

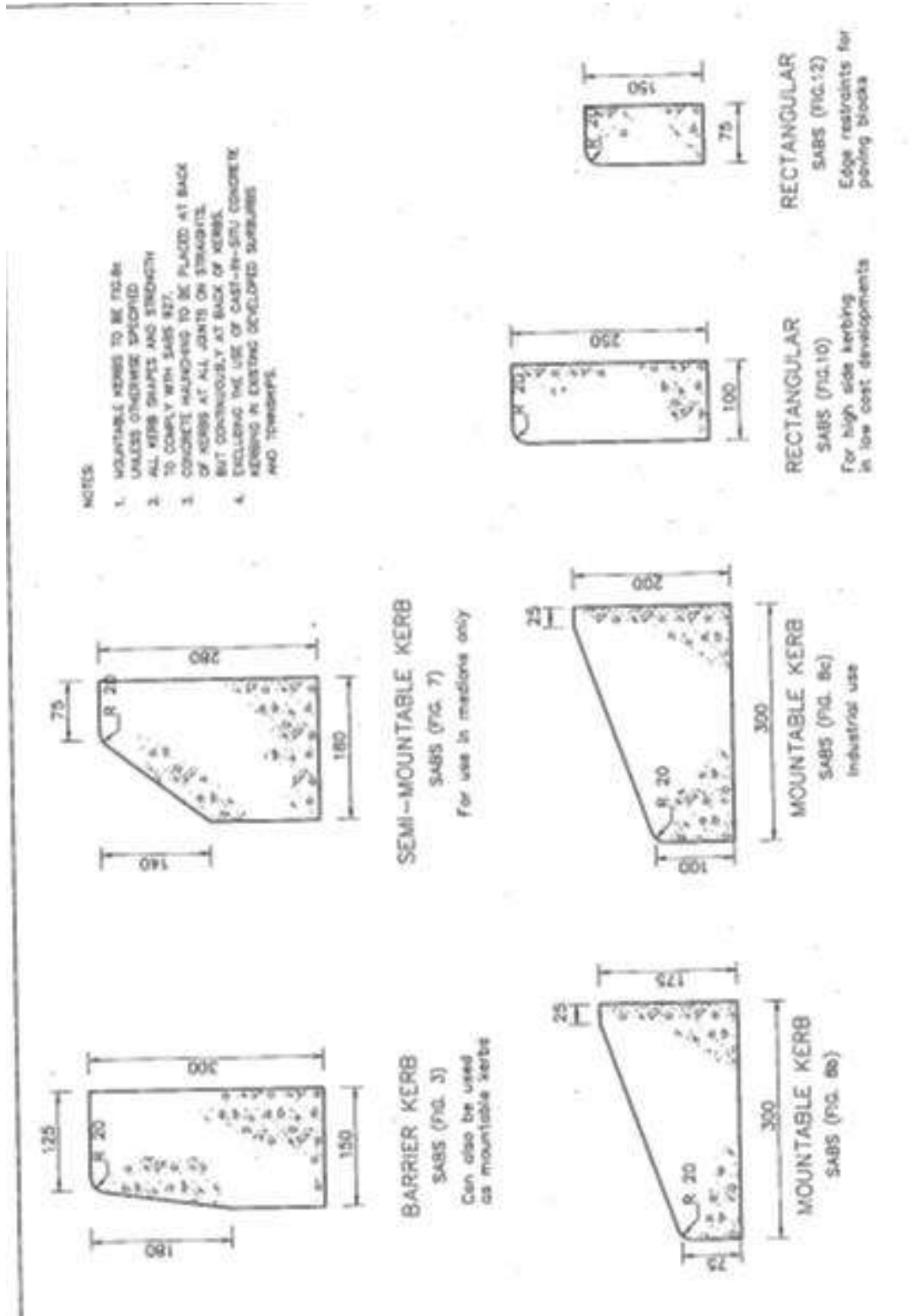

Municipality 1		Municipality 2		Contractor	
----------------	--	----------------	--	------------	--

Specifications for Laying of Kerbs

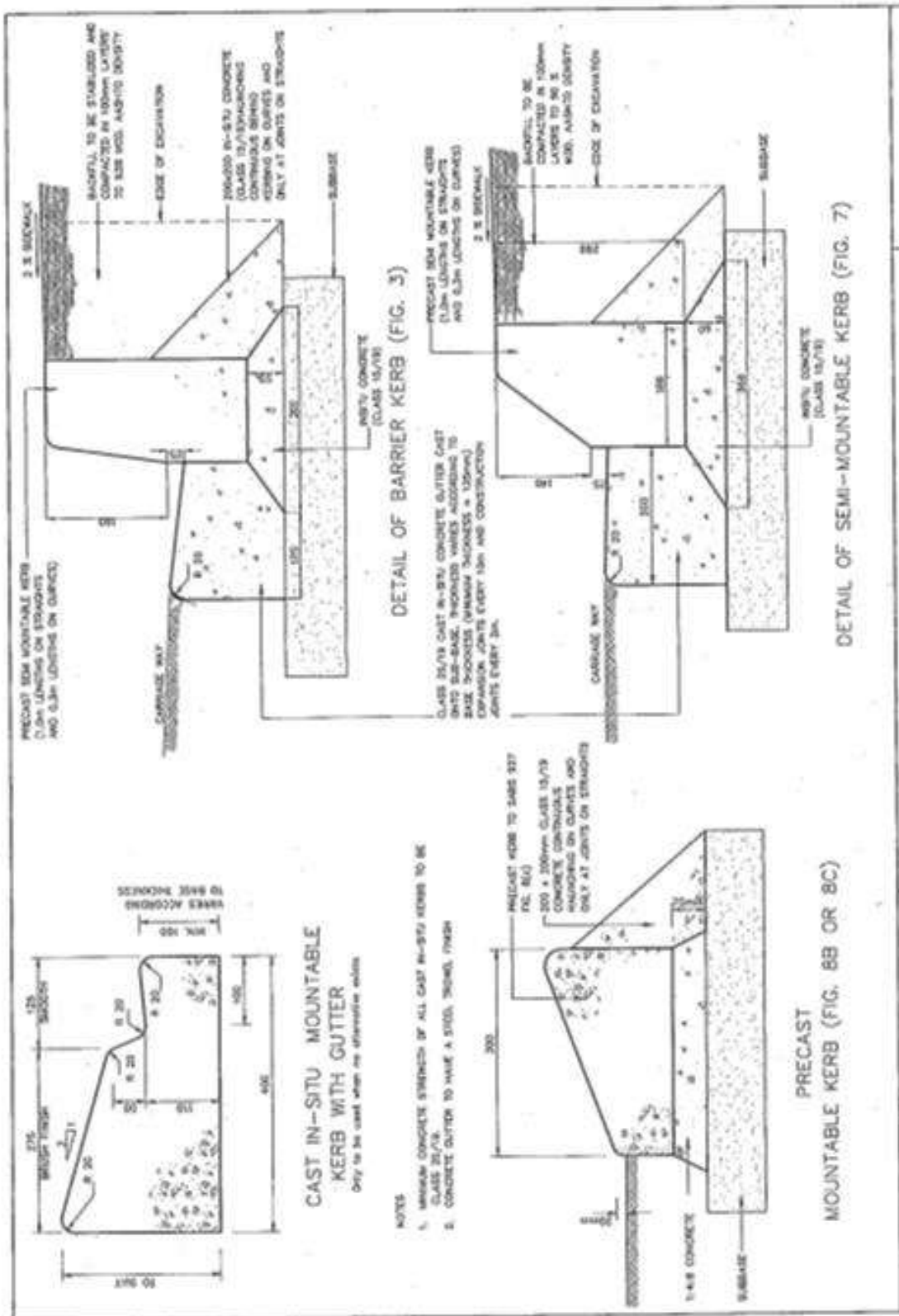

Municipality 1		Municipality 2	Contractor
----------------	--	----------------	------------

ANNEXURE B7

SPECIFICATIONS FOR TRAFFIC SIGNS

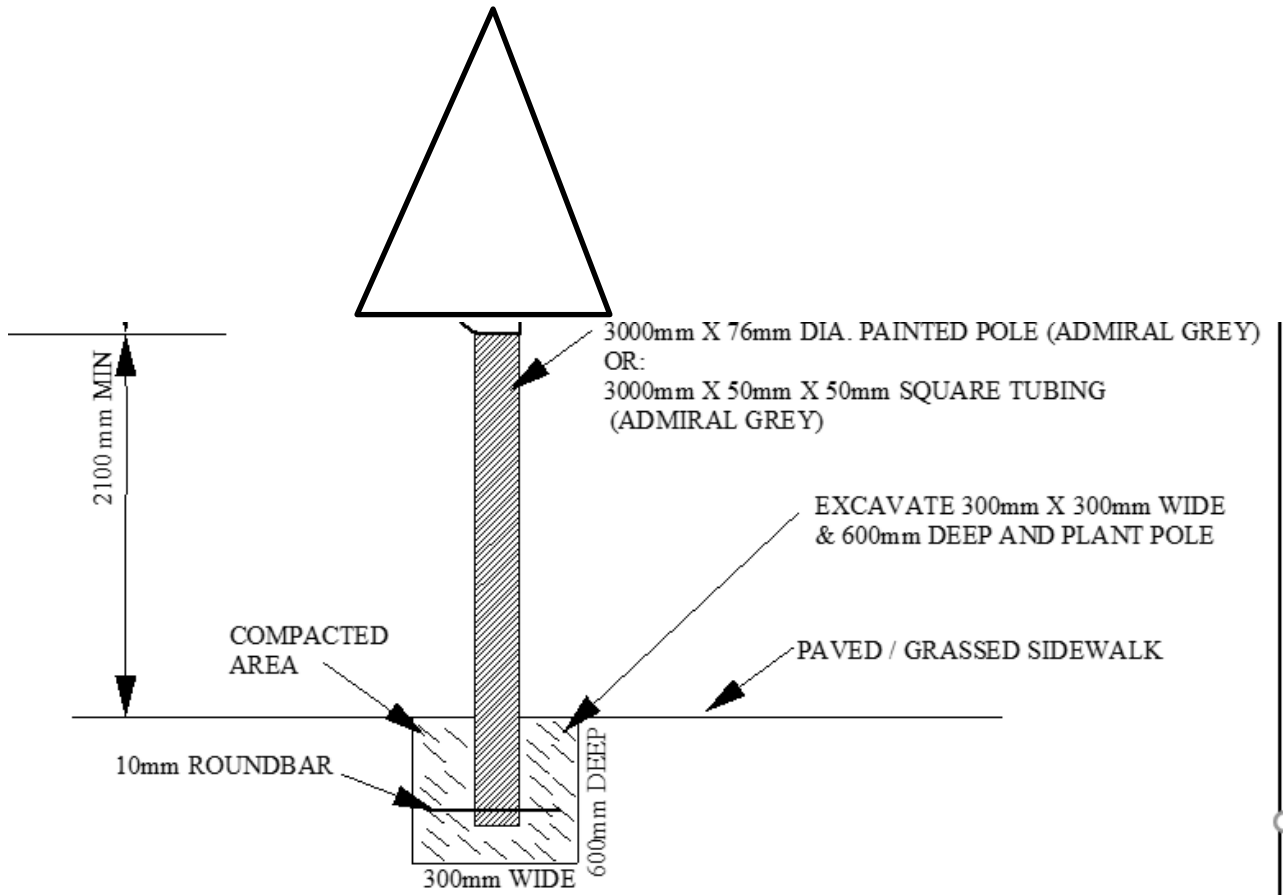

Municipality 1		Municipality 2		Contractor	
----------------	--	----------------	--	------------	--

ANNEXURE C 1





Traffic accommodation for road reserve and on shoulders.

13.8.8

SHORT TERM WORKS

13.8.6 Fixed Site - Work on Shoulder

- 1 The temporary signing treatment illustrated in Figure 13.35 is intended for short term work located on the shoulder of a public road, either in the sense that the work is actually on the shoulder, or is immediately adjacent but outside the shoulder, but requires occupation of the shoulder by the work unit. In situations such as this, if the work unit's support vehicle is equipped with flashing yellow warning lights, it may benefit the safety of the workers for the vehicle to be parked on the shoulder, at the end of the Buffer Zone, between the workers and approaching traffic.
- 2 If the work is carried over into darkness, the TRAFFIC CONE delineation devices TD4 shall be provided with retroreflective sleeves or they shall be replaced by DELINEATOR PLATE hazard marker signs TW401/TW402. Cones used on high speed roads shall have a height of at least 700 mm. For details of delineator and cone spacings refers to table 13.4.
- 3 Tapers used for this type of work site treatment should be in accordance with Table 13.5.
- 4 Advance warning signs should be located up to 600 m in advance of the start of the taper for sites with operating speeds in excess of 80 km/h. In addition, because the signing levels are minimised, extreme care must be taken to note any features of each specific work site which may reduce the effectiveness of the signs. In particular, vertical curvature and overhanging vegetation should be assessed. If there are adverse conditions and operating speeds are in excess of 80 km/h, or even 60 km/h signs, should be displayed in accordance with Figure 13.26. The requirements of Table 13.1 should be adhered to with regard to the minimum mounting height of temporary signs.

MAINTENANCE UNIT INVENTORY			
Sign	No	Size (mm)	Quantity ^a
	TW336	1200	2
	TW330	1200	1
	TR104	1200	1
	TD4	450 750	15 Min. plus 10 per 100m site length
	TR201-80 TR201-60	1200	2 2

Checklist

- are operating speeds in excess of 80 km/h?
- does the unit have enough cones/delineators for correct spacings?
- does the unit have delineators or retroreflective sleeves for cones for night time use?
- is the site set up with adequately safe Buffer Zones (see Figure 13.20)?
- is there adverse vertical or horizontal curvature on the approach to the site?
- can signs be mounted higher to improve early warning of the site if required?

ANNEXURE C 2

Traffic accommodation for road reserve and on shoulders.

Municipality 1		Municipality 2		Contractor	
----------------	--	----------------	--	------------	--

13. See Subsection 13.8.6 for Sign Sizes.

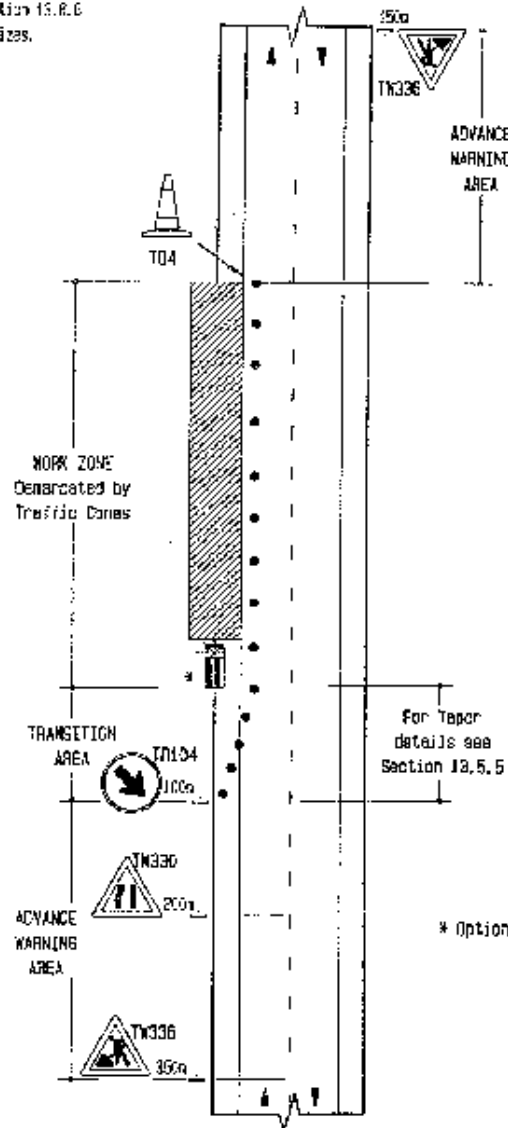

- NOTES:
1. Cones should be replaced by delineators if the work area represents a night time hazard.
 2. Cones used on high speed roads should have a minimum height of 100 mm.
 3. Spacing of signs may be increased to start from 100 m if speeds are 80 km/h or higher or sight distance is limited.
 4. The imposition of a temporary speed limit should be considered if operating speeds are in excess of 80 km/h.
 5. Lane markings should be in accordance with Table 13.5.

* (Optional) treatment

Fig. 13.35 Fixed Site - Work on Shoulder

ANNEXURE C 3

Traffic accommodation for road reserve and on shoulders.

Municipality 1		Municipality 2		Contractor	
----------------	--	----------------	--	------------	--

13.8.2

13.8.3 Maintenance in Road Reserve

1. This application represents the lowest signing level covered in this Chapter. This signing level is appropriate ONLY when the work concerned does not encroach nearer to the edge of the roadway than the shoulder break point. Typical activities which might warrant this low level of signing are:



- (a) verge grass-cutting;
- (b) cleaning of side drains or cross drain inlets and outlets;
- (c) fence repairs;
- (d) electric post repair/maintenance/replacement.

2. As soon as workers are required to move closer to the travelled way, additional signing consistent with Figures 13.36, 13.38 or 13.41 to 13.43 should be used.

3. If the maintenance work gradually progresses along the road reserve, the TW386 signs should be moved forward with the work so that they are never more than 600 m from the work.

4. All workers should still be provided with the recommended bright clothing, even when working off the road edge (see Figure 13.30).

5. The sign inventory indicated is a minimum for the type of work concerned. Any work unit undertaking this type of work is likely to be a general maintenance unit and will probably have a minimum sign inventory consistent with most tasks in this section.

MAINTENANCE UNIT INVENTORY			
Sign	NO	SIZE (mm)	Quantity
	TW386	1200	2
	TIN 11.3	1200	4
	FLAG	450 X 450	2

Checklist

- Is the site set up with adequately safe Buffer Zones (see Figure 13.20)?
- Are workers likely to get within 3 m of passing vehicles?
- Is the maintenance unit vehicle and equipment well off the road?
- Can signs be clearly seen by approaching drivers - if not move them further out?
- Is a higher level of signing appropriate to ensure worker and public safety?

ANNEXURE C 4

Traffic accommodation for road reserve and on shoulders.

Municipality 1		Municipality 2		Contractor	
----------------	--	----------------	--	------------	--

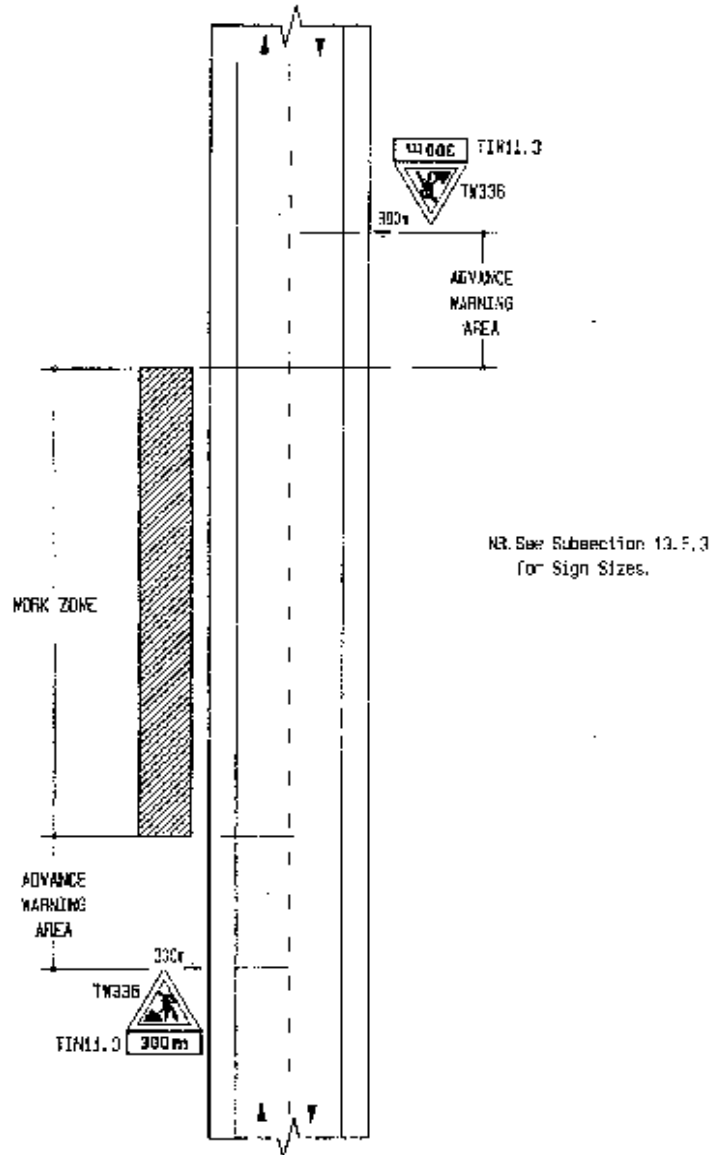

Fig. 13.32 Maintenance in Road Reserve (off the road)

Municipality 1		Municipality 2		Contractor	
----------------	--	----------------	--	------------	--

Municipality 1		Municipality 2		Contractor	
----------------	--	----------------	--	------------	--