



Ref: Maropeng Mokhatla (SCM)
Tel: (011) 951-2541/2014/16

maropengm@mogalecity.gov.za

REQUEST FOR FORMAL WRITTEN PRICE QUOTATIONS

**Procurement from R30 000.00 up to a transaction value of R 200 000.00 (including Vat)
(For publication on Mogale City Website and Notice Boards)**

Kindly furnish Mogale City Local Municipality with a written quotation on the goods listed hereunder:

RFQ: F (SCM) 09/2013

QUOTATIONS ARE HEREBY INVITED FROM SERVICE PROVIDERS WITH A CIDB GRADING OF 1GB FOR THE CONVERSION OF A CHANGEROOM INTO A KITCHEN FOR SUPPLY CHAIN MANAGEMENT UNIT.

Advertising date: Tuesday 9 April 2013

Closing date and time: Wednesday 17 April 2013 @ 11:00

Compulsory Site Inspection: Will be held on Friday 12 April 2013 at 13:00, at the Supply Chain Boardroom, Civic Centre, Krugersdorp.

The quotation must be submitted on the official quotation document (including all the required annexures) and must be delivered by hand before the official closing date and time to:

The SCM Unit of MCLM
Civic Centre
Corner Market & Commissioner Streets, Krugersdorp
Upper Level West Wing
Tender Box 1

The following conditions will apply:

- Quotation documents can be downloaded from the website www.mogalecity.gov.za or collected from the Supply Chain Management Unit, Finance Dept, Civic Centre, Krugersdorp.
- The lowest or any quotations will not necessarily be accepted and MCLM reserves the right to accept the quotation in total or only in part.
- To participate in MCLM's quotation procurement of goods and services, suppliers are requested to register on the MCLM supplier database. Forms available from SCM Unit or website.
- No late quotations delivered after the official closing date and time will be accepted.
- Price(s) quoted must be valid for at least thirty (30) days from date of your offer.
- Price(s) quoted must be firm and must be inclusive of VAT.
- A firm delivery period must be indicated.
- A valid, original tax clearance certificate must be attached.
- This quotation will be evaluated in terms of the 80/20 preference point system as prescribed in the Preferential Procurement Policy Framework Act (No 5 of 2000) and for this purpose the following forms need to be completed and submitted:
 - **MBD 4: Declaration of interest;**
 - **MBD 6.1: HDI preference points (7 points);**
 - **MBD 6.3: Promotion of SMME's (3 points)**
 - **MBD 6.11: Preference points to Mogale based companies (10 points)**
 - **MBD 8: Declaration of bidders past supply chain management practices**

If the MBD forms are not completed & submitted, your quotation will be rejected.

- No quotation will be considered from persons in service of the state (MDB 4)

**MOGALE CITY LOCAL MUNICIPALITY
REQUEST FOR FORMAL WRITTEN PRICE QUOTATION**

Mogale City Local Municipality requests a quotation on the goods listed hereunder on the Request for Quotation Forms. Please furnish all the information as requested and return the quotation on the date stipulated. Late and incomplete submissions will invalidate the quotation submitted.

RFQ NUMBER:	RFQ- F(SCM) 09/2013																				
ADVERTISING DATE:	Tuesday 9 April 2013																				
DEPARTMENT:	Finance: Supply Chain Management Unit																				
DELIVERY PERIOD	Completion period after the date of official orderdays / weeks																				
EVALUATION CRITERIA:	<p>The RFQ will be evaluated on the basis of the 80/20 point system as stipulated in the Preferen8</p> <ul style="list-style-type: none"> • 80 points Price • 20 points for BBBEE level of Contribution <ul style="list-style-type: none"> ○ Previous experience in this field as well as references (6 points). ○ Resources available to execute this project (4 points) <p>For purposes of comparison and in order to ensure meaningful evaluation, bidders are requested to furnish detailed information in substantiation of compliance to functionality criteria mentioned. A bidder that scores less than 5 points in respect of functionality will be disqualified. If any criterion is rated zero points, the tenderer will be rejected, even if the required 5 out of 10 points are achieved.</p> <p>All quotations received will be evaluated on the 80/20 point scoring basis. The 80 points will be for Price and 20 points are for Broad Based Black Economic Empowerment (BBBEE) for attaining the BBBEE status level of contribution in accordance with the table below:</p> <table border="1" style="margin-left: auto; margin-right: auto;"> <thead> <tr> <th>BBBEE Status level of contributor</th> <th>Number of points(80/20 system)</th> </tr> </thead> <tbody> <tr><td>1</td><td>20</td></tr> <tr><td>2</td><td>18</td></tr> <tr><td>3</td><td>16</td></tr> <tr><td>4</td><td>12</td></tr> <tr><td>5</td><td>8</td></tr> <tr><td>6</td><td>6</td></tr> <tr><td>7</td><td>4</td></tr> <tr><td>8</td><td>2</td></tr> <tr> <td>Non –complaint contributor</td> <td>0</td> </tr> </tbody> </table>	BBBEE Status level of contributor	Number of points(80/20 system)	1	20	2	18	3	16	4	12	5	8	6	6	7	4	8	2	Non –complaint contributor	0
BBBEE Status level of contributor	Number of points(80/20 system)																				
1	20																				
2	18																				
3	16																				
4	12																				
5	8																				
6	6																				
7	4																				
8	2																				
Non –complaint contributor	0																				

OTHER DOCUMENTS REQUIRED:	<ul style="list-style-type: none"> • Original, valid tax clearance certificate • Company registration documents • Copies of ID's of shareholders • Completed MBD 4, MBD 6.1, MBD 6.11 and MBD 8, MBD 9 • Copy of latest municipal account • Schedule (fixed prices including Vat) 			
CLOSING DATE AND TIME:	Wednesday 17 April 2013 at 11h00			
SUBMISSION OF QUOTES	Tender box 1 Reception desk of SCM Unit Civic Centre Krugersdorp			
ENQUIRIES	Maropeng Mokhatla at (011) 951 2541 /071 884 6958			

Conditions:

- All prices quoted must be **inclusive of VAT**.
- All prices submitted must be fixed prices for the period of the quotation.
- Prices quoted must include delivery charges and goods must be delivered to corner Church and Fountain Street, Krugersdorp.
- If the price schedule is not signed the quotation will not be considered.
- No tipp-ex or correction fluid to be used on the quotation documentation- will lead to instant disqualification.
- Quotations completed in pencil will be regarded as invalid.

NAME OF THE BIDDER: TEL/ CELL NO:

CONTACT PERSON FAX NUMBER.....

F (SCM) 09/2013

CONVERTING CHANGE ROOM INTO KITCHEN FOR SUPPLY CHAIN SECTION

C3.1 STANDARD SPECIFICATIONS

PORTION 1: THE WORKS

SCOPE

The Project Specifications covers the general description of the project, the facilities available and the requirements to be met.

STATUS

In the event of any discrepancy between the Project Specifications, Additional Specifications, Technical and Particular Specifications, the Schedule of Quantities or the Drawings, the Project Manager shall be notified in writing, and the Project Manager's decision will be final.

PORTION 1: THE WORKS

22 PS 1 GENERAL DESCRIPTION

The Municipality would like to appoint a Building contractor for work to be executed in Mogale City Local Municipality: **Supply Chain New Kitchen**. The scope of works for the quotation included the following:

The scope of works for this quotation:

- 1. Demolition of Existing Wall, Tiles and Plumbing Fixtures/Fittings**
- 2. Install plumbing for new kitchenette**
- 3. Kitchen cupboards installation**
- 4. Install New Electrical Plugs**
- 5. Repair and make good existing wall and surfaces**
- 6. Tiling**
- 7. Clean site of works**

The full descriptions are as per the Bill of Quantities attached.

Approximate quantities of each type of work are given in the schedule of quantities.

F (SCM) 09/2013

PS 2 DESCRIPTION OF SITE AND ACCESS

The site is located in the Mogale City Local Municipality Building on the corner of Commissioner and Market Street, Krugersdorp.

Access to the Centre is from Commissioner street, but the successful contractor will have access from the West of the building.

As the centre is multifunctional centre IN FULL OPERATION SPECIAL CARE MUST BE GIVEN NOT TO DESTURB ANY PART OF THE BUILDING THAT IS NOT ASSOCIATED WITH THE WORKS.

The contractor should ensure that his work is in full compliance with his own Occupational Health and Safety requirements and that the work is registered with the department of labour before construction commence.

PS 3 EXISTING SERVICES ON SITE

The Contractor must ascertain himself with the condition on site at the compulsory site visit as noted in the invitation to tender. The Contractor must ascertain himself with the following conditions on site before submitting quotations

- Positioning of existing services,
- Type of Existing Aluminium Doors
- Facilities on site (water, sewer and electricity)

PS 4 CONSTRUCTION PROGRAMME

Contractor shall submit a programme of work to the Engineer not later than 7 days after the Contractor has been notified of the acceptance of his tender and only after discussions with the Engineer. If necessary, the Engineer may instruct the Contractor to adjust his programme to suit other activities.

If the programme has to be revised by reason of the Contractor falling behind his programme, he shall produce a revised programme showing how he intends to regain lost time in order to ensure completion of the works within the time for completion as defined in his original program

F (SCM) 09/2013

PS 6 SITE FACILITIES AVAILABLE

PS 6.1 CONTRACTORS OFFICE AND STORAGE AREA

The Contractor shall make his own arrangements with the Local Municipality to erect his offices, stores and storage camp for material on the site. The Contractor shall arrange for: his own fencing and security of his campsite.

PS 6.2 WATER, ELECTRICITY, SEWERAGE AND TELEPHONE FACILITIES

PS 6.2.1 WATER

There is existing facility at site; however, necessary permission for its usage should be obtained from Mogale City Local Municipality.

The Contractor shall comply with any measures regarding restrictions on the use of water laid down by the water supply authority from which water is directly or indirectly obtained.

PS 6.2.2 ELECTRICITY

Although there is electricity for normal lighting purposes, it should be noted that this is for normal hand tools only. The Contractor shall bear the full cost of any such temporary supply and consumption during the construction period should he need 3 phase power supply by means of a generator.

PS 6.2.4 TELEPHONE

The Contractor must make his own arrangements for telephone facilities for construction purposes and shall be liable for any payments required in this regard during the construction period.

PS 7 SITE FACILITIES REQUIRED FOR THE ENGINEER

PS 7.1 GENERAL

The Engineer will have a part time representative on site. An office for the Engineer's representative will not be required.

PS 8 SITE INSTRUCTION BOOK

The Contractor must supply an A4 size triplicate book (Croxley™ JD555 or similar) that must be available to the Engineer or his representative at all times. The purpose of this book is for site instructions and will also be available to the Contractor. Two of the three pages for each entry should be removable.

F (SCM) 09/2013

PS 9 SITE MEETINGS

The Contractor or his authorised representative shall attend weekly meetings held on the site with representatives of the Engineer at dates and times to be determined by the Engineer. Such meetings will be held to evaluate the progress of the contract and to discuss matters pertaining to the contract which any of the parties represented may wish to raise.

PS 10 SETTING OUT OF THE WORKS

Setting out of the Works is the Contractor's responsibility and shall not be scheduled separately for payment purposes and the cost of setting out shall be deemed to be included in the various items included in the Contract. The Engineer will provide a reference drawing at site handover, all final positions of walls, doors etc to be signed off by Engineer before construction.

The Contractors' attention is drawn to the contents of Clause 14 of the Special Conditions of Contract.

Before the Contractor may start any construction work, he shall check all reference pegs and beacons and accept their accuracy in writing.

PS 14.4 REINSTATEMENT OF WALKWAYS

Contractor to reinstate existing walkway as found when site was accepted outside the office of works.

PS 16 INSTRUCTIONS BY MANUFACTURERS

Only when the Engineer issues written instructions, will any deviations from the prescribed use, mixing, application, fixing etc. by the manufacturer of patented materials be acceptable. All materials to be SABS approved.

PS 17 SAMPLES

The Contractor shall provide all samples of materials prescribed by the contract documents or the Engineer to the Engineer without delay. Materials or work that does not comply with the approved samples shall be rejected. The Engineer is entitled to subject material samples to any test he may deem necessary to ensure compliance with the relevant specification.

The Engineer shall keep the approved samples as a reference standard for the duration of the Contract. No materials of inferior quality shall be used by the Contractor.

All costs incurred in the provision of samples to the Engineer shall be for the Contractor's account.

F (SCM) 09/2013

PS 18 TESTING AND QUALITY CONTROL

All reasonable required test by the Engineer shall be for the Contractor's account.

PS 19 ADDITIONAL INFORMATION SUPPLIED BY EMPLOYER

Certain information contained in these contract documents, or provided separately, is being offered in good faith. However, in the circumstances pertaining to the type of information supplied, no guarantee can be given that all the information is necessarily correct or representative. More specifically this applies to all material surveys and reports and similar information, the accuracy of which is necessarily subject to the limitation of testing, sampling, the natural variation of material or formations being investigated and the measure of confidence with which conclusions can be drawn from any investigations carried out. It also applies to the positions of existing services as indicated on the drawings.

The Employer accepts no liability for the correctness or otherwise of the information supplied or for any resulting damages, whether direct or consequential, should it prove during the course of the contract that the information supplied is either incorrect or not representative. Any reliance placed by the tenderer on this information shall be at his own risk.

Tenderers shall inspect and examine the site and its surroundings and shall satisfy themselves before submitting their quotations.

PS 22 DRAWINGS

All information in the possession of the Contractor that is required by the Engineer's representative to complete the as-built drawings must be submitted to the Engineer's representative before a Certificate of Completion will be issued.

Only figured dimensions shall be used and drawings shall not be scaled unless required by the Engineer. The Engineer will provide the dimensions that may have been omitted from the Drawings.

PS 23 SAMPLES

Materials or work that does not conform to the approved samples submitted in terms of Sub clause 26(4) of the General Conditions of Contract, will be rejected. The Engineer reserves the right to submit samples to test to ensure that the material represented by the sample meets the specification requirements.

F (SCM) 09/2013

PS 24 WORKMANSHIP AND QUALITY CONTROL

The onus to produce work that conforms in quality and accuracy of detail to the requirements of the Specifications and Drawings rests with the Contractor, and the Contractor shall, at his own expense, institute a quality-control system

PS 25 REDUNDANT MATERIAL, RUBBISH AND WASTE

All identified building material that is identified by the engineer will become the property of the Mogale City maintenance department.

Redundant materials and items of equipment shall become the property of the Contractor. All redundant materials, rubbish and waste arising from the work must be removed and the site and buildings left clean and tidy.

PS 26 NON-WORKING DAYS AND HOURS

The Contractor shall not work on any statutory public holidays or on any public holidays declared by the Government to be statutory non-working days, except for work related to repair fatal and emergency breakdowns which influences the functionality of any of the installations.

Working hours might be limited and the Contractor shall work in close co-operation with the User Client and Engineer in this regard.

F (SCM) 09/2013

<u>BILL OF QUANTITIES</u>			
<u>DESCRIPTION</u>	<u>UNIT</u>	<u>QUANTITIES</u>	<u>RATE</u>
DEMOLITION EXISTING WALL, DOOR AND TILES AND REMOVE EXISTING PLUMBING FIXTURES/FITTINGS (WC AND SHOWER ETC) AS INDICATED ON A DEMOLISHED LAYOUT PLAN. MAKE GOOD OF WALL AND FLOOR WHERE THE WALL AND PLUMBING FIXTURES WERE REMOVED/DEMOLISHED. ALL USABLE MATERIAL TO BE HANDED TO MOGALE CITY MAINTENANCE DEPARTMENT. DISPOSE OF ALL REMAINING MATERIAL TO DUMP SITE. DUMP SITE TO BE LOCATED BY CONTRACTOR AND RATE TO INCLUDE ALL COSTS OF TRANSPORT, AND DUMPING AND DISPOSAL	m2	50	
INSTALL PLUMBING FOR NEW KITCHEN SINK WHICH INCLUDE THE PROVISION FOR A DRAIN POINT TO THE EXISTING SEWER LINE. THE RATE WILL INCLUDE THE PLUMBING WORK NEEDED TO SUPPLY HOT AND COLD WATER TO THE NEW KITCHEN SINK FROM THE EXISTING GEYSER. ALLOW 2m OF PIPEWORK FOR EACH SERVICE. (HOT, COLD, 50mm DRAIN PIPE) RATE TO INCLUDE SUPPLY OF MATERIALS NEEDED AND THE CONSTRUCTION THEREOFF AND PRESSURE TEST.	NR	1	
INSTALL NEW KITCHEN CUPBOARDS AS INDICATED ON A NEW KITCHEN LAYOUT PLAN, POSTFORM TOP WITH SINGLE SINK AND SABS APPROVED MIXING TAP SIMILAR TO "COBRA SINK MIXER" WITH 5 YEAR GUARANTEE. COLOUR AND TYPE TO MATCH EXISTING KITCHEN CUPBOARDS AND TOPS IN RENUE SECTION.	NR	2	

INSTALL 3 NEW ELECTRICAL PLUGS FOR FRIDGE, MICROWAVE AS INDICATED ON A NEW KITCHEN LAYOUT PLAN.	NR	4	
FLOOR AND WALL TILES: INSTALL 500 X 500mm "Porcelain Tiles" or similar approved. NOTE: WALL TILES TO BE INSTALLED TO UNDER-SIDE OF SLAB.	m2	50	
CLEAN ENTIRE KITCHEN, PASSAGE HALL AND FINISH	m2	50	
<u>NOTE: ALL DIMENSIONS AND LEVELS TO BE CHECKED ON SITE BEFORE ANY WORK COMMENCES</u>			
<u>A certificates certifying this specifications must be supplied on completion of the job.</u>			
SUB-TOTAL (EXCL VAT)			
14% VAT			
TOTAL AMOUNT (INCL VAT)			

Signature: Date:

F (SCM) 09/2013

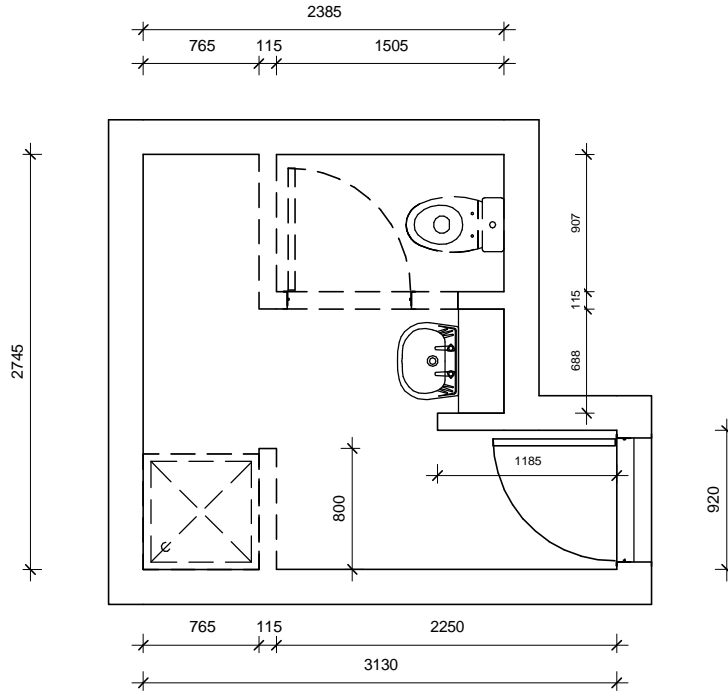

Demolished Layout
1:50

F (SCM) 09/2013

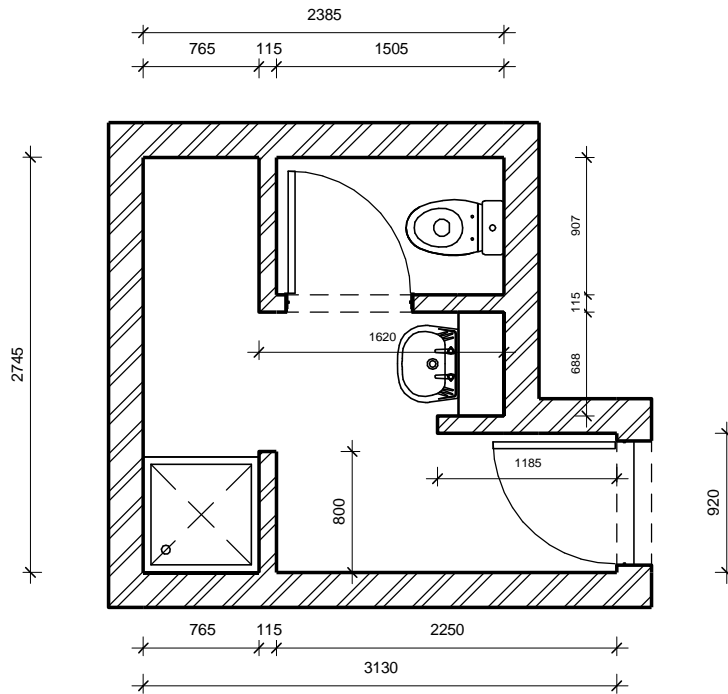

Existing Change Room
1:50

F (SCM) 09/2013

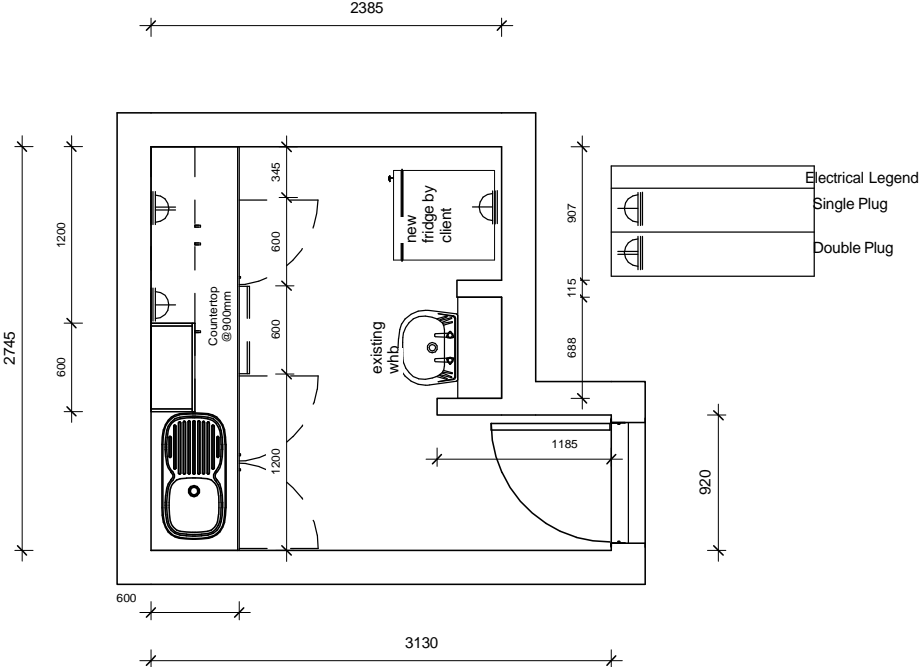

Proposed New Kitchen Layout

1:50

F (SCM) 09/2013



